

RESIDENTIAL

WALL MOUNTED

MULTI SPLIT



Anytime, Anywhere!

DUAL COOL ThinQ™

with Voice Control



OK Google, turn on the air conditioner.

Sure, turning on



Key Features

Enhance your daily life with LG ThinQ

Cool home when you arrive
"It would be wonderful if my place is already cool when I arrive."

Check electricity bills throughout the month
"How much have I been using the AC lately?"

Switch off AC after you've left
"Oh no! Did I remember to turn off the AC?"

No need to search for the remote control your AC with your phone
"Where's the remote control? I don't want to move an inch from my bed"

Voice control for a better life

- **Very intuitive** : It has never been that simple to control a device.
- **Accessible to everyone** : Young to elder people. Increase your comfort by asking so.
- **Time saving** : Don't look for the remote control anymore, just say it with your voice instead.

Simple voice control, time saving & accessible to everyone

No need to wander around searching for your AC's remote control. LG DUALCOOL LG ThinQ models are also compatible with AI speakers such as LG ThinQ with Google Assistant, Alexa, Google Home and more. From now on, don't bother pressing any buttons. Use your voice instead.

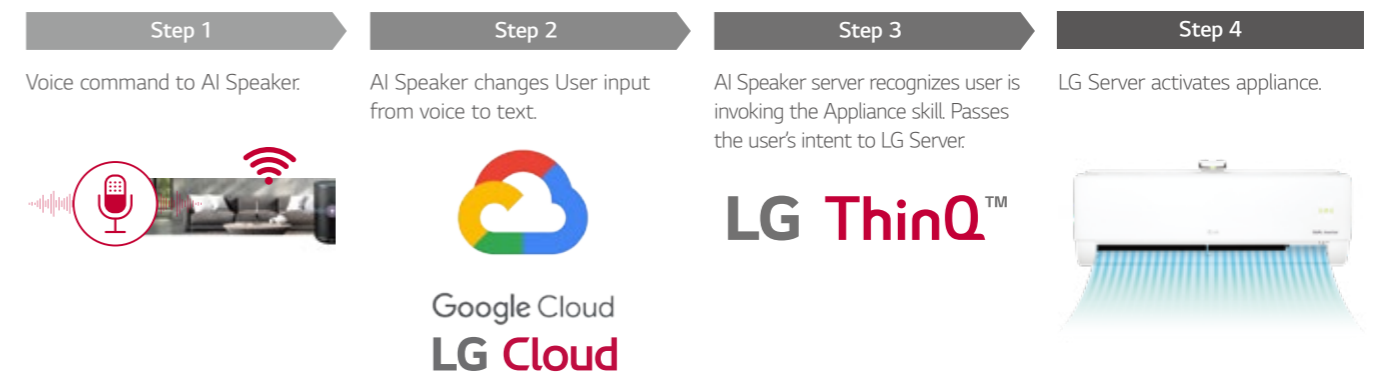

※ LG SmartThinQ is now renamed to LG ThinQ.
 ※ Smart features and voice assistant product may vary by country and model. Check with your local retailer or LG for service availability.

Don't Worry!
Now, breathe healthily



DUALCOOL

with Air Purification



Cooling + Heating + Air purification



Comfort 365 days

Removes Ultrafine dust



Ion Diffuser &
Micro Dust filtering system

Real-time control & monitoring



LG ThinQ APP

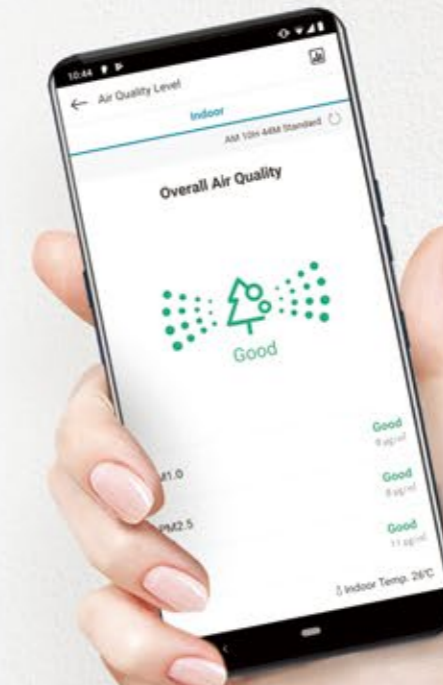

Key Feature

Air conditioner and air purifier in one

PM1.0 sensor is automatically activated and filtration system uses 5 million ions to capture and remove microscopic dust particles.



※ Formerly branded LG SmartThinQ is now LG ThinQ.
 ※ Smart features and voice assistant product may vary by country and model. Check with your local retailer or LG for service availability.

Four seasons of breeze

Enjoy comfort in all four seasons with cooling, heating, and air purification.



Conveniently manage air quality with the LG ThinQ app

Let's check now! History of your air quality by LG ThinQ.



4 Way Swing (Indirect Air Flow)

Cool air reaches out to the entire room regardless of where the air conditioner is installed.

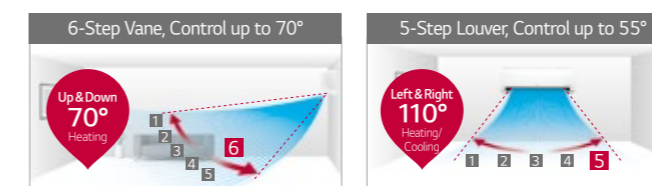

10-Year Inverter Compressor Warranty











With confidence in product quality and a desire to enhance the lives of customers, LG provides a 10-year warranty on the Residential Air Conditioners' Inverter Compressor.



LINE-UP

INDOOR UNITS

○ Single Split Only ● Compatible ● Multi Split Only











MODEL	KBTU	5	7	9	12	15	18	24
	KW	1.5	2.1	2.6	3.5	4.2	5.3	7.0
ARTCOOL	Gallery				○ A09FT NSF ○ A12FT NSF			
	Mirror			● AM07BP NSJ	○ AC09BQ NSJ ○ AC12BQ NSJ		○ AC18BQ NSK ○ AC24BQ NSK	
	Silver				○ AC09SQ NSJ ○ AC12SQ NSJ		○ AC18SQ NSK	
DUALCOOL	Prestige				○ F09MT NSM ○ F12MT NSM			
	Air Purification				○ AP09RT NSJ ○ AP12RT NSJ			
	Deluxe			● DM07RP NSJ	○ DC09RQ NSJ ○ DC12RQ NSJ		○ DC18RQ NSK ○ DC24RQ NSK	
	Deluxe 2				○ DC09RT NSJ ○ DC12RT NSJ			
	Standard Plus		● PM05SP NSJ	● PM07SP NSJ	○ PC09SQ NSJ ○ PC12SQ NSJ	● PM15SP NSJ	○ PC18SQ NSK ○ PC24SQ NSK	
	Standard 2			● MS07ET NSJ	○ S09ET NSJ ○ S12ET NSJ		○ S18ET NSK ○ S24ET NSK	
	Standard				○ S09EQ NSJ ○ S12EQ NSJ		○ S18EQ NSK ○ S24EQ NSK	
	Standard 3				○ S09ES NSA ○ S12ES NSJ ○ S12EW NSJ			

※ Refer to multi split line up for 5, 7, 15KBTU indoor unit connection.

LINE-UP

OUTDOOR UNITS

○ Single Split Only ○ ● Compatible ● Multi Split Only

MODEL	KBTU	9	12	14	16	18	21	24	27	30
	KW	2.6	3.5	4.1	4.7	5.3	6.2	7.0	7.9	8.8
ARTCOOL	Gallery		○ A09FT UL2	○ A12FT UL2						
	Mirror		○ AC09BQ UA3 ○ AC12BQ UA3			○ AC18BQ UL2		○ AC24BQ U24		
	Silver		○ AC09BQ UA3 ○ AC12BQ UA3			○ AC18BQ UL2				
DUALCOOL	Prestige		○ F09MT U24	○ F12MT U24						
	Air Purification		○ AP09RT UA3	○ AP12RT UA3						
	Deluxe		○ DC09RQ UL2	○ DC12RQ UL2			○ DC18RQ UL2		○ DC24RQ U24	
	Deluxe 2		○ DC09RT UA3	○ DC12RT UA3						
	Standard Plus		○ PC09SQ UA3 ○ PC12SQ UA3			○ PC18SQ UL2		○ PC24SQ U24		
Standard	Standard 2		○ S09ET UA3	○ S12ET UA3		○ S18ET UL2		○ S24ET U24		
	Standard		○ S09EQ UA3 ○ S12EQ UA3			○ S18EQ UL2		○ S24EQ U24		
	Standard 3		○ S09ES UA3	○ S12ES UA3 ○ S12EW UA3						

WALL MOUNTED

ARTCOOL | Prestige | DUALCOOL with Air Purification | Deluxe | Standard Plus | Standard



ARTCOOL SERIES



ARTCOOL Gallery
DUAL Inverter

The design of LG air conditioners is fashionably elegant in such a way that it reigns supreme compared to others. Customize your space.



ARTCOOL Silver
DUAL Inverter



ARTCOOL Mirror
DUAL Inverter

In addition to modern lines and classic style, LG ARTCOOL offers the most outstanding air conditioning solution in a complete and attractive package.

DUALCOOL SERIES



PRESTIGE DUAL Inverter

LG Prestige offers one of the most comprehensive air conditioning solutions by providing supreme energy efficiency and a tranquil environment.



DUALCOOL WITH AIR PURIFICATION

Enjoy a comfortable home throughout all four seasons with cooling, heating and air purification.



DELUXE DUAL Inverter

LG Deluxe's minimalist design combines with advanced technology to go above and beyond the essential elements of an air conditioner.



STANDARD PLUS DUAL Inverter

The LG Standard Plus boasts compact size, powerful cooling performance and convenient, sleek design.



STANDARD DUAL Inverter

LG Standard features all the sophistication of a modern residential air conditioner integrated with LG's advanced technology.

UNIQUE FEATURES

Smart

Enjoy anytime, anywhere access to your air conditioner with LG's ThinQ technology.

Energy Efficiency

LG's revolutionary inverter technology provides world-class energy efficiency by minimising energy consumption.

Perfect Healthcare

The PM 1.0 auto sensor combined with advanced filtration technologies protect users from harmful substances such as micro-dust, viruses, allergens, and odors.

Fast Cooling & Heating

Regardless of the outdoor temperature, LG air conditioners distribute cold or hot air fast, reaching every corner of even your largest rooms with powerful cooling or heating.

Extreme Durability

In any environmental conditions, LG's air conditioners can bring customers peace of mind through product durability.

Comfort

LG air conditioners provide a comfortable indoor environment with low noise levels and optimized vane adjustment capability that ensures even air flow.

Quick & Easy Installation

Installation has never been easier as with the delicately designed installation elements of LG air conditioners

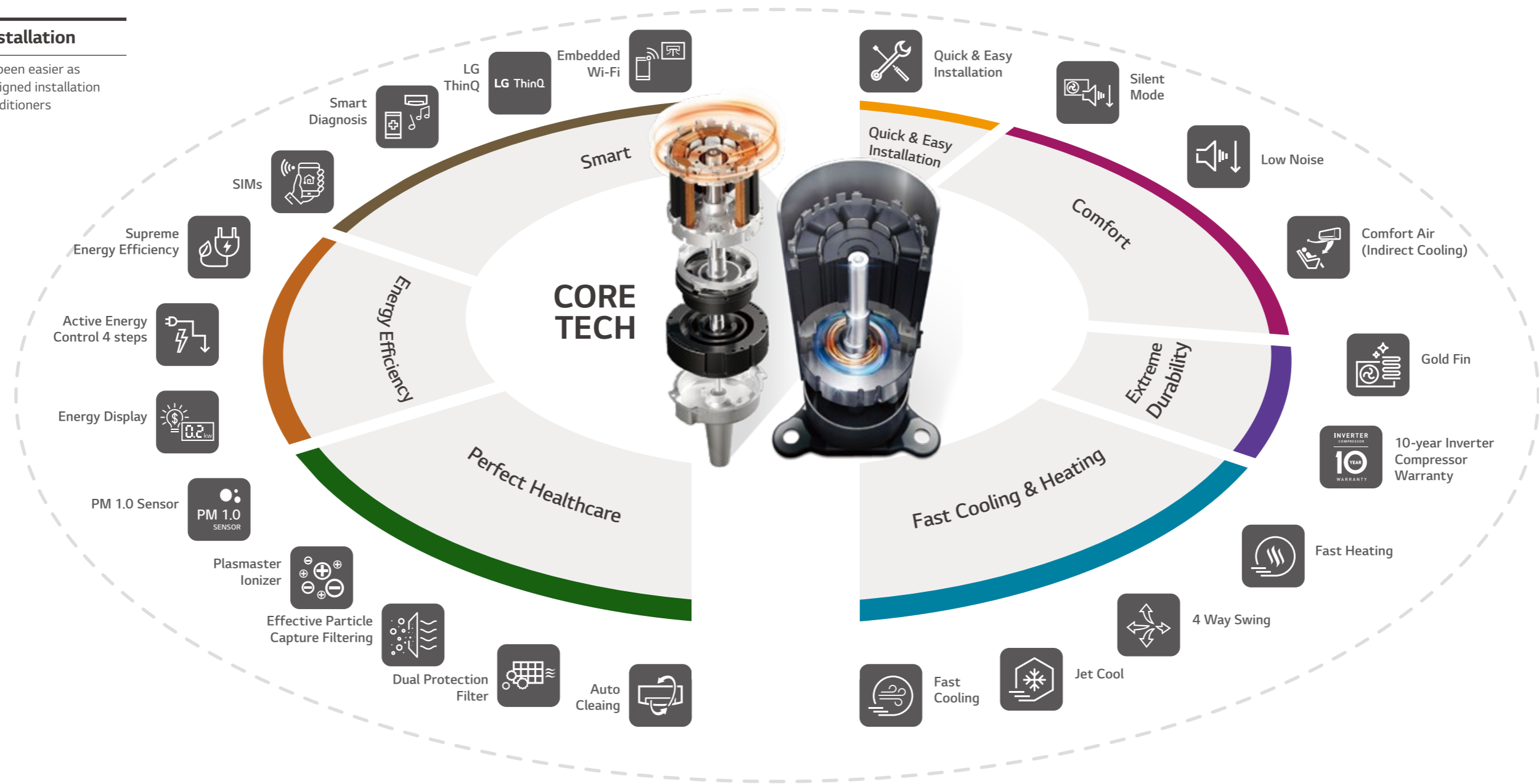

CORE TECH



Dual Inverter Compressor

• What is the Dual Inverter Compressor?

A compressor is the heart of an air conditioner, and monitoring whether it works properly, effectively, or noisily that can cause stress as well as cost more money. LG's Dual Inverter Compressor provides an effective solution, resulting in an air conditioner that cools faster, lasts longer, and operates quieter than conventional models.



• How it Works

Varied-Speed Dual Rotary

A compressor motor with a wider rotational frequency that is energy efficient and has a higher volumetric quick cooling capacity than any conventional compressors.

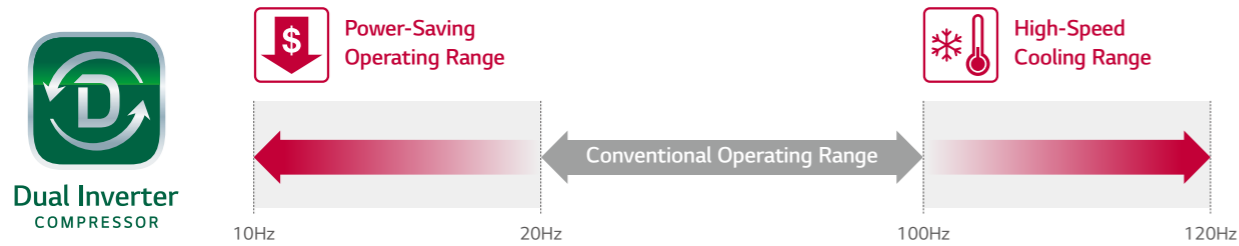

• Product Reliability Improvement

The Dual Inverter Compressor reduces the vibration and with it the sound pressure levels. The reduction in vibration reduces the possibility of fractures occurring in the the surrounding pipework.

CORE TECH



R32 Refrigerant

- R32 is more environmental friendly compared to former refrigerant

• Pain Point

Due to accelerated global warming and the destruction of the ozone layer, various international conventions and meetings are held to enhance restrictions to the use of refrigerant or enforce the use of eco-conscious refrigerants. In order to reduce environmental destruction, refrigerant R32 is internationally acclaimed for being Eco-friendly. This low volume refrigerant is as efficient as any conventional refrigerant but boasts a 68% reduced global warming potential.



• How it Works

Utilizing a small amount of the R32 refrigerant also qualifies it to be a highly green efficient system.

Alleviate Global Warming & Ozone Layer Destruction

R32 efficiently works even in small volume compared to existing R410A refrigerant, which decreases potential hazard of global warming.

	R410A	R32
Composition	Blend of R32 50% + R125 50%	Pure R32 (No blend)
GWP (Global Warming Potential)	2087.5	675

High Compressibility

R32's high compressibility rate gives more powerful cooling performance and efficiency compared to existing refrigerant R22 and R410A.

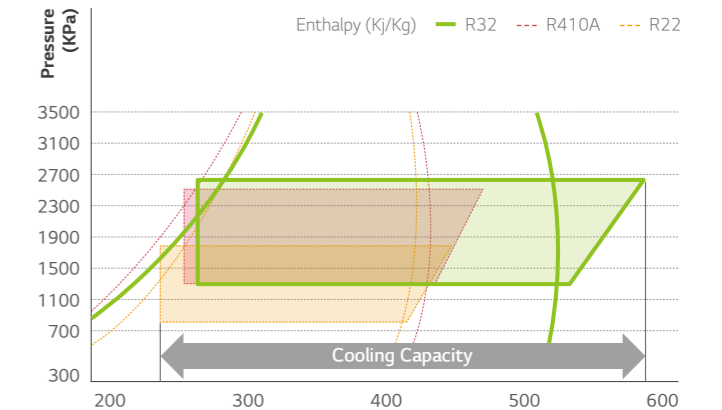

• Benefit

Eco-conscious refrigerants reduce environmental pollution.

SMART



Embedded Wi-Fi

Control your air conditioners by using Android or iOS based smartphones. This advanced technology provides you many benefits.

• LG ThinQ



Download the LG ThinQ app from Google or Apple app stores.



LG ThinQ

• How it Works

Embedded Wi-Fi modem

Enable "LG ThinQ" on your air conditioner.



By using the embedded Wi-Fi modem, get ready for innovation without boundaries.



Easy Registration and Log-in

Follow the interactive set-up LG Account steps that will activate LG ThinQ's impressive features.



Wi-Fi Connectivity

Each individual member of your family can customize the air conditioner temperature and fan speed accordingly and then save the settings in their app to run it later. These settings can be saved for each air conditioner too.

Multiple Devices



※ Can be controlled by multiple users, but not simultaneously

Multi-Control



SMART

• Benefit

Simple operation for various functions

On / Off, Current Temp



Mode, Set Temp



Vane Control

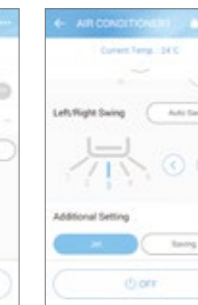
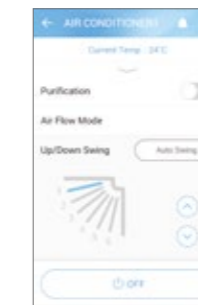

Straight-forward management

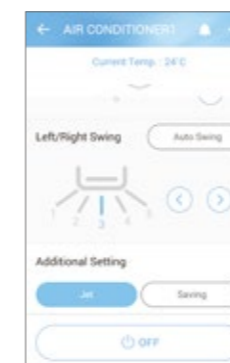

Reservation

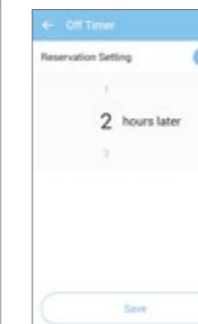

Energy Monitoring



Smart Diagnosis



Filter Management

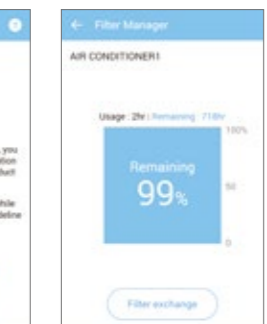

Integrated Home Appliances Control

Monitor and control your LG appliances from one place.



Access your air conditioner anytime and from anywhere with a Wi-Fi equipped device and LG's exclusive control app, ThinQ.



SMART

Smart Diagnosis

Smart Diagnosis allows you to check setup, installation, troubleshooting and other information conveniently from your smartphone.

- ※ Specifications may vary for each model.
- ※ When connected to Multi ODU, Smart Diagnosis function may not be supported.

What is Smart Diagnosis?

Smart Diagnosis allows users to conveniently check setup, installation, troubleshooting and other information directly from a smartphone.

- ※ Builds upon widespread smartphone use and offers greater USP diversification
- ※ Perfect for consumers who are unable to view information about their air conditioner via a display or remote control.

• How it works

By using "LG ThinQ" App and clicking "Start Smart Diagnosis", monitor and check diagnosis results conveniently via Wi-Fi.

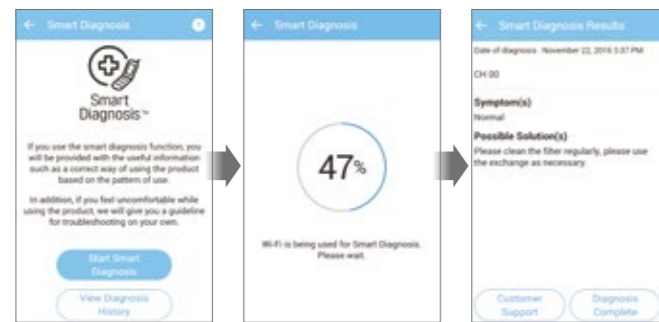

※ When the model doesn't provide embedded Wi-Fi, diagnose by buzzer sound with the same app and remote controller.

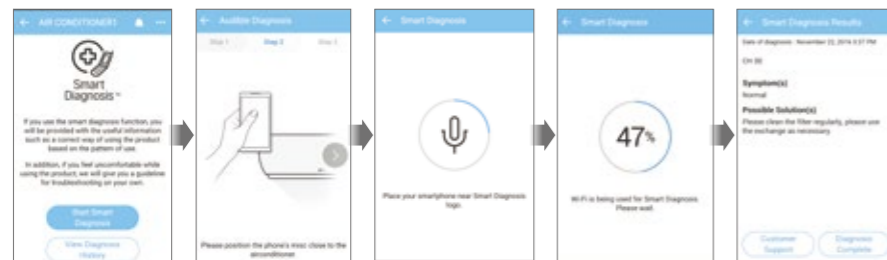

SMART

• Benefit

Easily comprehensible error messages make detecting a solution and contacting the service center simple and convenient.

For Consumer



For Installer and SVC



- Easily check operational status of a product without a display or one that provides limited information.
- Save energy by monitoring key operational information and power consumption.
- Using the Maintenance Guide helps to improve device performance and increase product life-span.

- Understand the product better by easily confirming operational status and information.
- Intuitively diagnose problems by comparing current and past usage data.
- Maintain installation capabilities and reduce installation errors by quickly confirming device operational status.

SMART

SIMs

By connecting SIMs chip, you can check the status of your air conditioner and diagnose problems from your smartphone.

- ※ Specifications may vary for each model.
- ※ When connected to Multi ODU, SIMs function may not be supported.

• What is the LG SIMs?

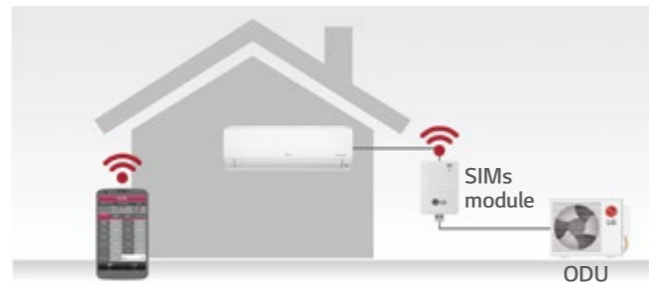

Monitor the status of your air conditioner and accurately diagnose problems by connecting it to a smartphone via a SIMs* chip.

* SIMs : Smart Inverter Monitoring System

• How It Works

- SIMs App**
1. Use a SIMs chip to connect a smartphone to an air conditioner.
 2. Monitor and diagnose problems in real time using the SIMs app.

• Benefit

Easy Monitoring
Diagnose problems anytime, anywhere with a SIMs chip.

Easy Diagnosis & Quick Response
Easily monitor IDU/ODU and diagnose problems. Save and review diagnostic data.

<p>Main Current outdoor temperature Indoor temperature Inverter Comp frequency Operating opening Error code / Frequency limits Indoor. Outdoor fan speed</p>	<p>Indoor Unit Indoor Unit capacity / Operation mode THM mode / REM mode FAN operating condition / EEV opening Room temperature / Suction Temperature Intermediate temperature Exit temperature</p>
<p>Outdoor Unit Frequency / Fan RPM DC Link / Input current Input voltage EEV operation mode Restart timer Compressor mode / EEV opening</p>	<p>Chart Room temperature Heat exchanger pipe temperature Compressor discharge temperature Frequency / Outdoor temperature Compressor suction temperature Electric current / Voltage</p>

Certificate
 US Radio Standard
 Canada Radio Standard
 Australia Radio Standard
 Europe Radio Standard

※ Smartphone Requirements (iOS : 6.1 or later, Android : 2.3 or later)

SMART

Low Refrigerant Detection

Early notification of low refrigerant protects your air conditioner from a risk of damage.

- ※ Specifications may vary for each model.
- ※ Depending on the experimental conditions.
- ※ When connected to Multi ODU, Low Refrigerant Detection function may not be supported.

• How It Works

Early Detection of Low Refrigerant Levels
The Air Conditioner is automatically shut down when low refrigerant level is detected.

- 3 Checkpoints for Low Refrigerant Level :**
- 1) The heat exchanger temperature is comparatively cool
 - 2) The outdoor unit is working properly
 - 3) The energy consumption is working under a standard pattern

If any of the above conditions are not met, for a maximum of 4 times, after 15 minutes of Air Conditioner operation, a Low Refrigerant level is detected and the Air Conditioner is shut down.

Capacity and Effectiveness of the Refrigerant Levels

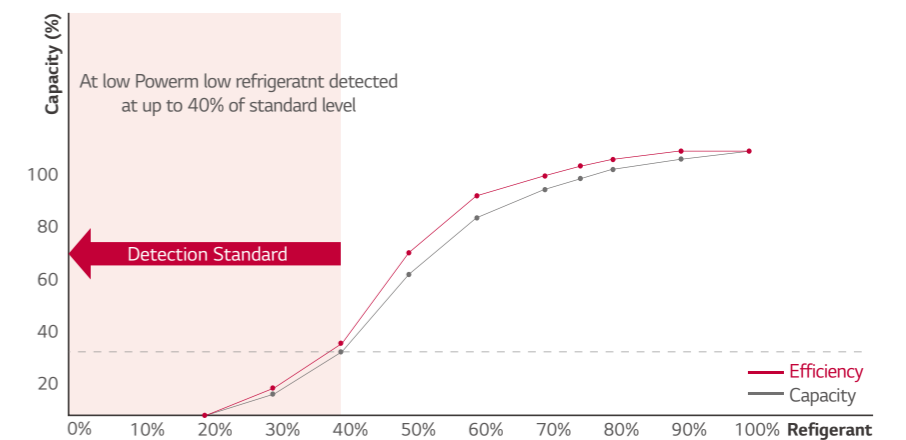

※ This function only works under the following conditions
 - Indoor/Outdoor temperature is up to 20 degrees Celsius
 - Cooling and dehumidification mode

• Benefit

Longer Lifespan for Air Conditioner



Notify You of Low Refrigerant Levels.
When Low Refrigerant Level is detected, it alternately shows CH and 36 on the display.

※ Some models show CH and 38 alternately on the display.

ENERGY EFFICIENCY

Supreme Energy Efficiency

LG's revolutionary Inverter technology boasts powerful yet quiet performance while minimising energy consumption. With world-class energy efficiency, enjoy comfort as well as energy savings.

※ Based on H09AL Model.
 ※ Specifications may vary for each model.

• High Efficient Compressor and Reversing Valve

Rotary Compressor and Motor Efficiency

The number of suction connections has been reduced from two to one to increase the efficiency of the refrigerant compression during low speed conditions. The DC motor in LG air conditioners remains unsurpassable incomparable to in the world's top class efficiencies.

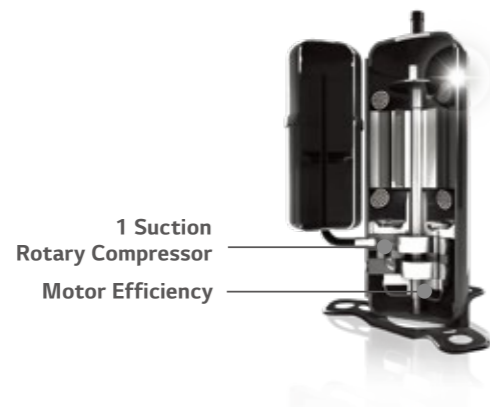

Bi-Stable Reversing Valve

The Input power of 4 way valve has been reduced to 0W by using a Bi-Stable type.

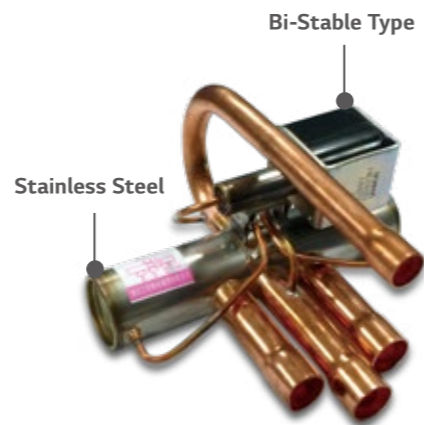

• Improved Inverter Drive Efficiency

Used to optimise the time of current flow by controlling the number of converter switching according to energy consumption status. Displays comparatively higher performance and advanced energy efficiency than conventional Inverter air conditioner by reducing power loss with an advanced material component called SiC.

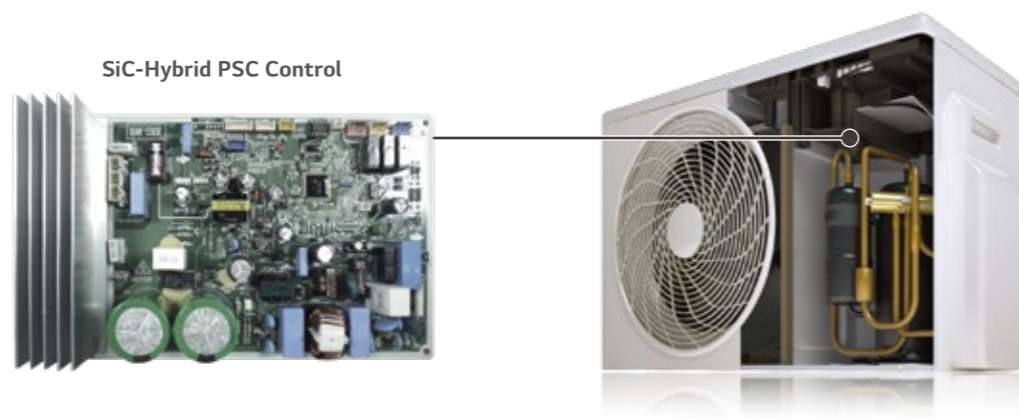

ENERGY EFFICIENCY

Active Energy Control 4 - Step

LG's Active Energy Control adjusts the energy consumption level and cooling capacity by controlling maximum frequency of the compressor motor.

※ Specifications may vary for each model.
 ※ Depending on the experimental conditions.
 ※ When connected to Multi ODU, Active Energy Control function may not be supported.

• Concept & Benefit

Cooling a home can come at a high cost particularly during the hot summer months. Avoid those costs and save energy by taking advantage of LG's 4-Step Energy Control System.

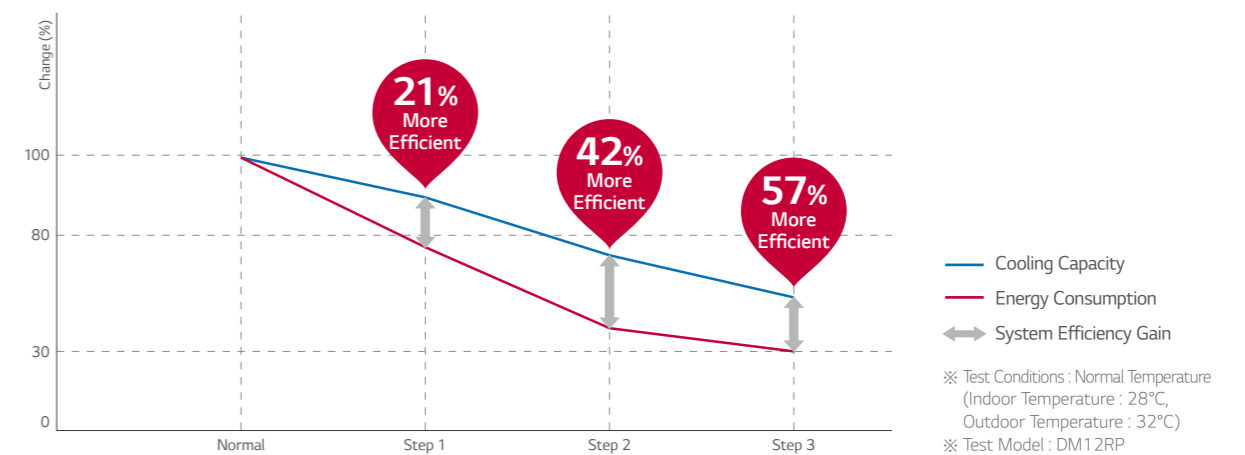

• How It Works

<p>Normal. 100% energy usage</p> <p>Many people and high-activity level.</p>	<p>Step 1. 80% energy usage</p> <p>Fewer people and moderate-activity levels.</p> <p>1 Clicks</p>
<p>Step 2. 60% energy usage</p> <p>Fewer people and low-activity levels.</p> <p>2 Clicks</p>	<p>Step 3. 40% energy usage</p> <p>Fewest people with no activity.</p> <p>3 Clicks</p>

ENERGY EFFICIENCY



Energy Display

LG's Energy Display panel monitors the amount of energy levels used. Reduce energy consumption while enjoying a comfortable indoor environment by checking your energy level directly on the AC panel.

※ Specifications may vary for each model.
 ※ When connected to Multi ODU, Energy Display function may not be supported.

• How it Works

Magic Display & Remote Control

With the push of a button on the remote control, indoor unit's LCD display shows the current and total energy use, thus making the users aware of reducing energy consumption.

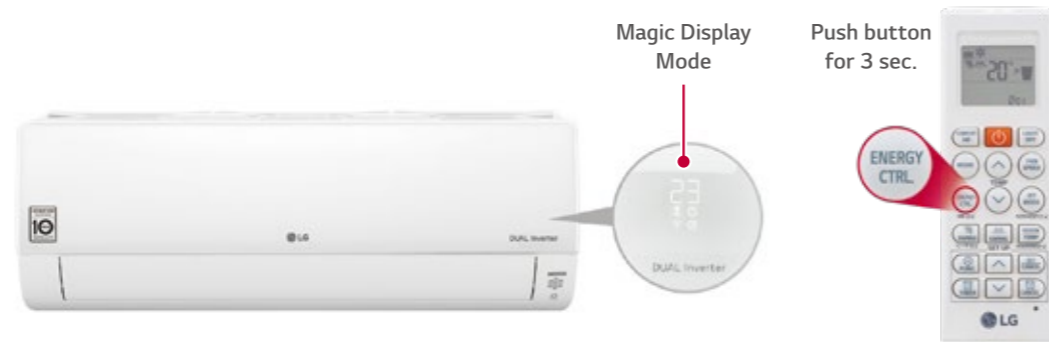

• Benefit

Normal Mode

Current Setting Temp



Electric Power

Displays Current Energy Use



PERFECT HEALTHCARE



Plasmaster™ Ionizer^{PLUS}

The powerful Plasmaster Ionizer protects you from bad odors and Escherichia coli and Staphylococcus in the surface with over 3 million ions to sterilize to make a safer, and cleaner environment.

※ Specifications may vary for each model.
 ※ Depending on the experimental conditions.

• How It Works

Sterilization and Deodorization (Utilizes Over 3 Million Ions)

Plasmaster Ionizer+ reduces E.coli and Staphylococcus in the surface with over 3 million ions.

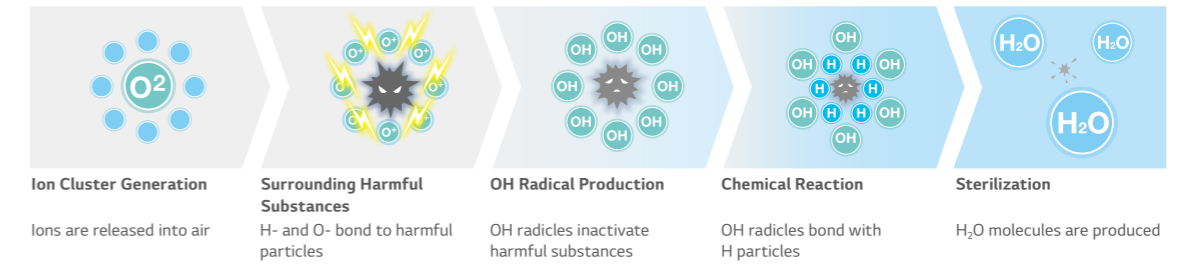

• Test Result

Sterilization Performance Evaluations

Sterilize Bacteria E.coli over 99.9% in 30 min

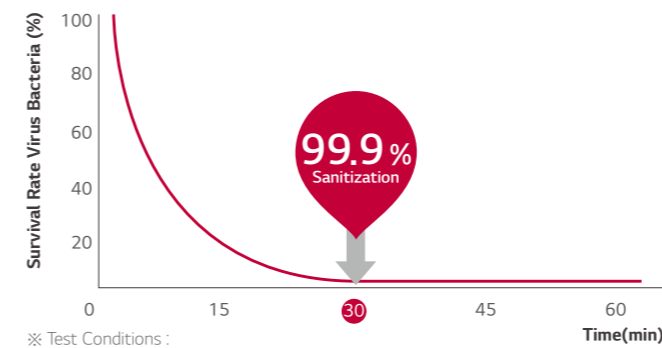

※ Test Conditions :
 Space : 52m³ Chamber (measuring with the specimen in the center of test chamber)
 Temperature & Humidity : Normal
 Bacteria : E coil colon bacillus
 Tested by Intertek

Sterilize staphylococcus over 99.6% in 60 min

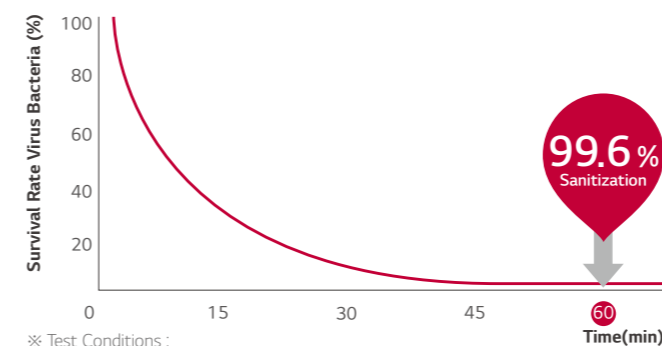

※ Test Conditions :
 Space : 52m³ Chamber (Measuring with the specimen in the center of test chamber)
 Temperature & Humidity : Normal
 Bacteria : Staphylococcus Aureus
 Tested by Intertek

2.1 odor strength decrease in 60 minutes

An odor of measured as 2 European odor units (ouE/m³) or less indicates that the level of odor falls within permissible limits.

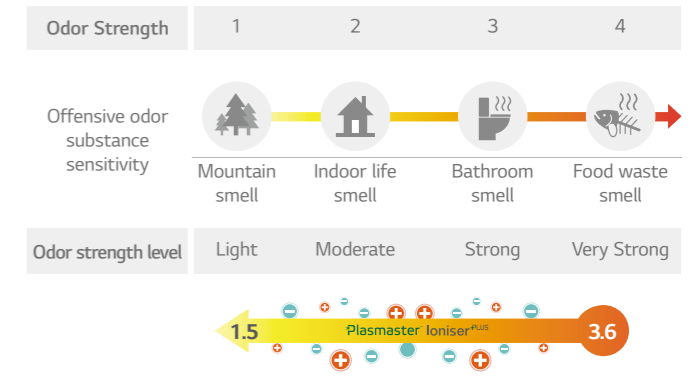

Odor strength reduce 3.6 → 1.5 / The Odor floating in the room as well as curtain and clothes.

※ Test conditions :
 Space : 8m³ Chamber
 Temperature & Humidity : Normal
 Tested by Intertek

PERFECT HEALTHCARE



PM 1.0 Auto Sensor

As AC turns on, PM 1.0 sensor automatically operates to capture and remove microscopic dust particles including ultra fine dust.

※ Specifications may vary for each model.
 ※ Depending on the experimental conditions.



- AQI (Air Quality Index) is displayed in unit of 1 within 8-999 $\mu\text{g}/\text{m}^3$.
- AQI (Air Quality Index) may continuously change according to changes in the indoor environment.
- Overall cleanliness color is displayed based on the highest contamination level among fine dust (PM10), ultra fine dust (PM2.5), and super ultrafine dust (PM1.0).
- Overall cleanliness color is displayed in 4 levels according to the indoor contamination level.
- If dust concentration is high, the difference between the displayed dust concentration and the actual dust concentration may increase.

• During the operation, if you press PM SENSOR button, you can check the indoor cleanliness in each level.

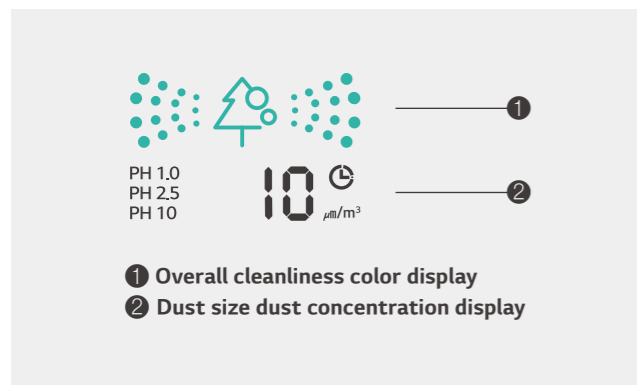

Color	Level	Display standard ($\mu\text{g}/\text{m}^3$)		
		Super ultra fine dust (PM 1.0)	Ultra fine dust (PM 2.5)	Fine dust (PM 10)
Green	Good	12 or less	12 or less	54 or less
Yellow	Normal	13 - 35	13 - 35	55 - 154
Orange	Bad	36 - 55	36 - 55	155 - 254
Red	Very Bad	56 or more	56 or more	255 or more

Guide to dust particles' size

- Fine dust : Dust with particle size of $10\mu\text{m}$ or less (Generated from workplace combustion, vehicle exhaust, etc.)
- Ultra fine dust : Dust with particle size of $2.5\mu\text{m}$ or less (Composed of ion component, carbon compound, and metal compound)
- Super Ultrafine dust* : Dust with particle size of $1.0\mu\text{m}$ or less (Cigarette smoke, etc.)

AQI (Air Quality Index) evaluation is carried out with LG standard test dust.

* Minimum capturing size of particle : $0.02\mu\text{m}$
 ※ PM : Particulate matter is the sum of all solid and liquid particles suspended in air many of which are hazardous.
 This complex mixture includes both organic and inorganic particles, such as dust, pollen, soot, smoke, and liquid droplets.

PERFECT HEALTHCARE



Dual Protection Filter

The Dual Protection Filter collects dust.

※ Specifications may vary for each model.
 ※ Depending on the experimental conditions.

• What is the Dual Protection Filter?

The Dual Protection Filter, designed to capture dust particles over $10\mu\text{m}$ in size, first line of defense against finer particles.



• Additional Benefit

Easy to Open

Easily detachable full surface cover helps clean the air conditioner flawlessly.



Easy to Clean

The filter is designed for easy handling and quick cleaning, which lengthens its lifespan.



PERFECT HEALTHCARE



Auto Cleaning

The interior of the air conditioner is maintained clean by drying off the heat exchanger, then sterilizing the interior once more.

※ Specifications may vary for each model.

• Pain Point

The main cause of odor within air conditioners is mold and bacteria growing on the heat exchanger. These germs can spread when the heat exchanger is wet.



• How It Works

Cleans Filter with Regular Air Flow

The comprehensive auto cleaning function prevents the formation of bacteria and mold on the heat exchanger, providing an enhancing environment.

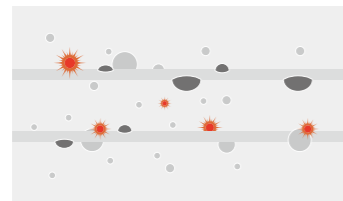

By dehumidifying, (Some models are by dehumidifying and ionizing), the auto cleaning function prevents potentially harmful substances from forming on the surface of the heat exchanger.

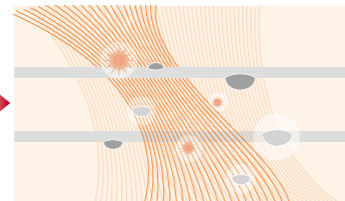

The indoor environment remains odorless with the advanced deodorizing function.



By preventing polluting of the heat exchanger caused by various germs and bacteria, the performance and life span of the air conditioner do not wither away even after a period of 10 years.

• Benefit

Removes Harmful Particles

Auto Cleaning provides clean air by preventing bacteria, mold and odors that can otherwise accumulate in an indoor unit.



Bacteria Prevention



Odor Elimination

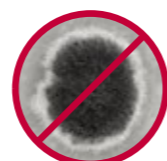

Mold Elimination

FAST COOLING & HEATING



Fast Cooling

The cool airflow reaches all the corners of the room, keeping the space cool and comfortable.

※ Specifications may vary for each model.

※ Depending on the experimental conditions.

• How It Works

Bigger Skew Fan

A 25% larger skew fan emanates highly powerful blasts of air.

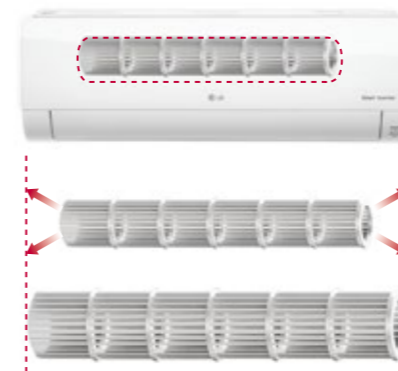

25% Larger (Fan Size)

Cooling Outlet

A larger, optimally designed cooling outlet emanates to large areas and cools spaces faster.

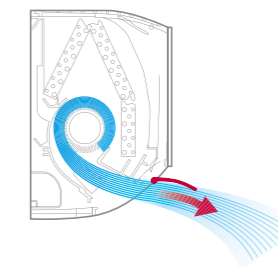

Conventional

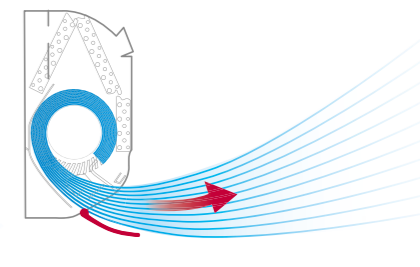

LG

• Test Result

Test Result

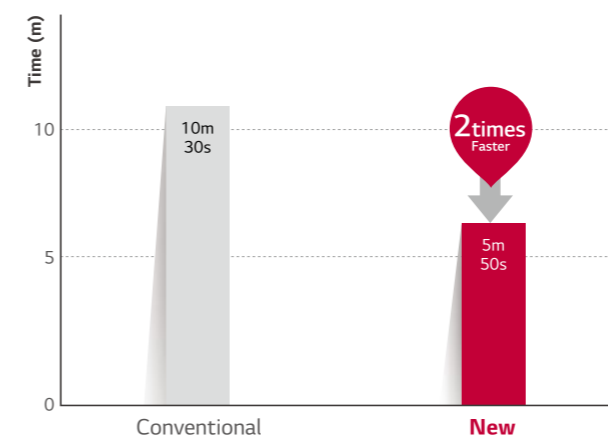

※ Test Conditions :
Indoor temperature 33°C, Outdoor temperature 35°C,
Relative humidity 60%, Setting temperature 24°C

Changes in Temperature Over 30 Minutes

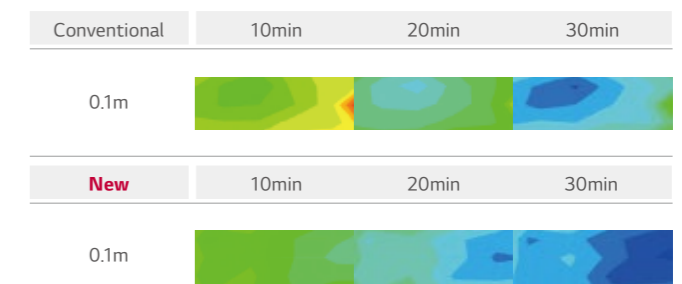

※ Test Conditions :
Outdoor temperature : 35°C, Indoor temperature : 33°C,
Humidity : 60%, Remote control : 24°C High

FAST COOLING & HEATING

Jet Cool

LG air conditioners provide optimized high-speed airflow, which can cool rooms faster while delivering cool air evenly in every direction.

※ Specifications may vary for each model.
 ※ Depending on the experimental conditions.

• How It Works

One Click "Jet Mode"

Reduces the temperature of outflowing air to 18°C for 30 minutes with just one click.

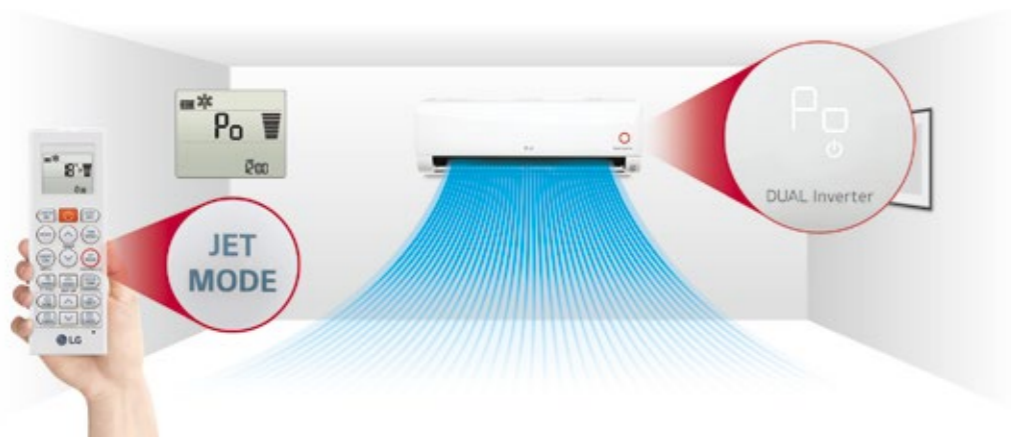

• More Powerful Performance

By reducing the second vortex, which decreases airflow within the air outlet, and enlarging the fan size, the amount of airflow is increased to 13.0 CMM.

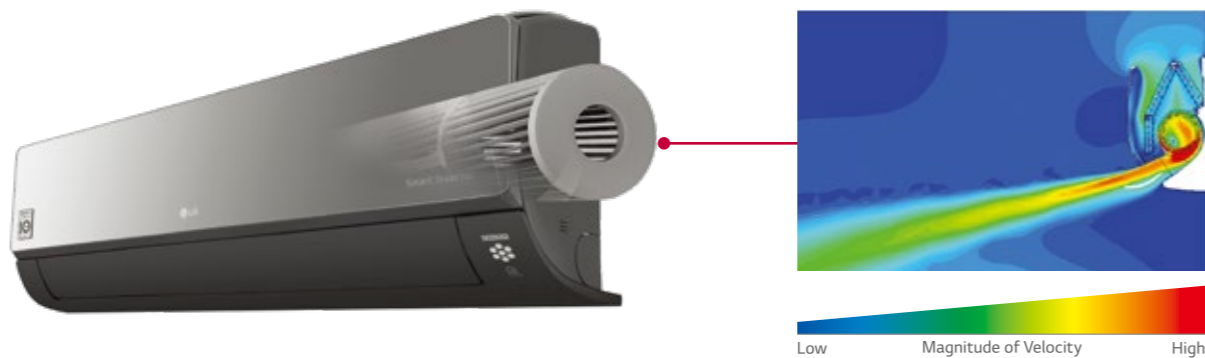

FAST COOLING & HEATING

4 Way Swing

Cool air reaches out to the entire room regardless of where the air conditioner is installed.

※ Specifications may vary for each model.

• How It Works

6-Step Vane, Control up to 70°

The vertical vane, which moves up and down, has 6 different settings including full-auto swing.

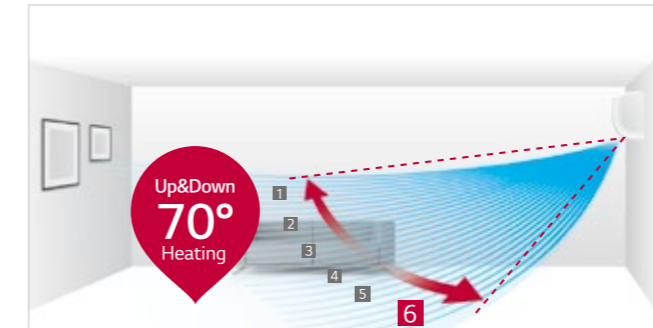

※ Angle can be different from each model and working mode.

5-Step Louver, Control up to 55°

The louver, which sways left and right, has 5 different settings including full auto-swing.



• Easy and Simple Control

Airflow direction can be changed by LG ThinQ Wi-Fi app.

Up/Down Swing

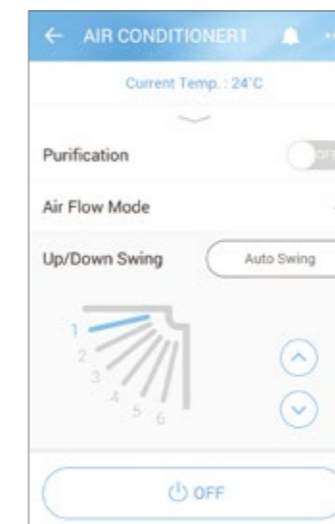

Left/Right Swing

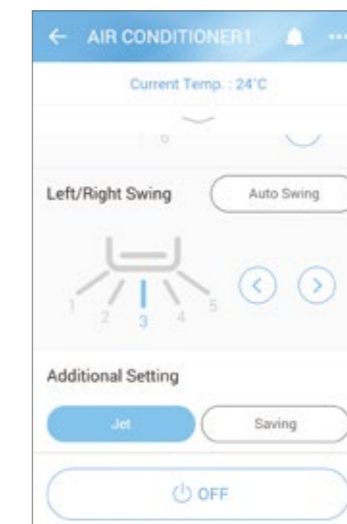

FAST COOLING & HEATING

Fast Heating

LG Residential Air Conditioners satisfy your heating needs while consuming less energy, by heating a wider space in a shorter period of time to create a warm and comfortable living environment.

※ Specifications may vary for each model.
 ※ Depending on the experimental conditions.

• How It Works

4 Way Auto Swing (Easy Airflow Control)

4 Way Auto Swing adjusts airflow based on the surrounding environment, allowing for optimal distribution of warm air to living areas and enabling quick heating.

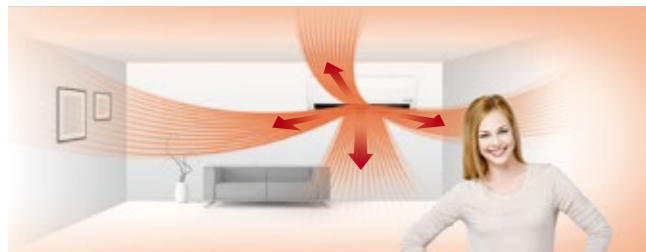

Vertical Airflow

When heating, the vane sends heated air downwards to maintain a pleasant and balanced room temperature.

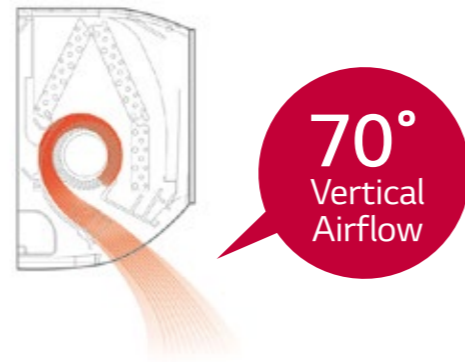

• Benefit & Test Result

22% Quick Heating

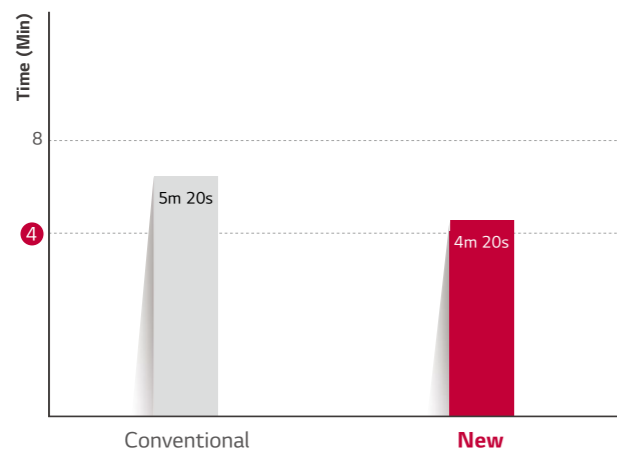

※ Test Conditions :
 Outdoor temperature : 7°C, Indoor temperature : 12°C,
 Humidity : 87%, Remote control : 30°C Power

Changes in Temperature Over 20 Minutes

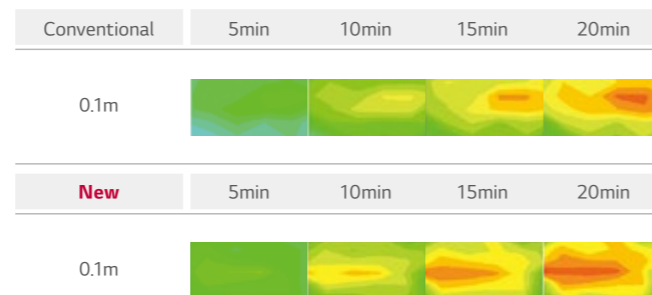

※ Test Conditions :
 Outdoor temperature : 7°C, Indoor temperature : 12°C,
 Humidity : 87%, Remote control : 30°C Power

EXTREME DURABILITY

10-Year Inverter Compressor Warranty

With confidence in product quality and a desire to enhance the lives of customers, LG provides a 10-year warranty on the Residential Air Conditioners' Inverter Compressor.

※ Specifications may vary for each model.

• What is the 10 Year Warranty?

With the 10-year warranty on the compressor, users can be assured of the functionality of our product for a longer period of time.

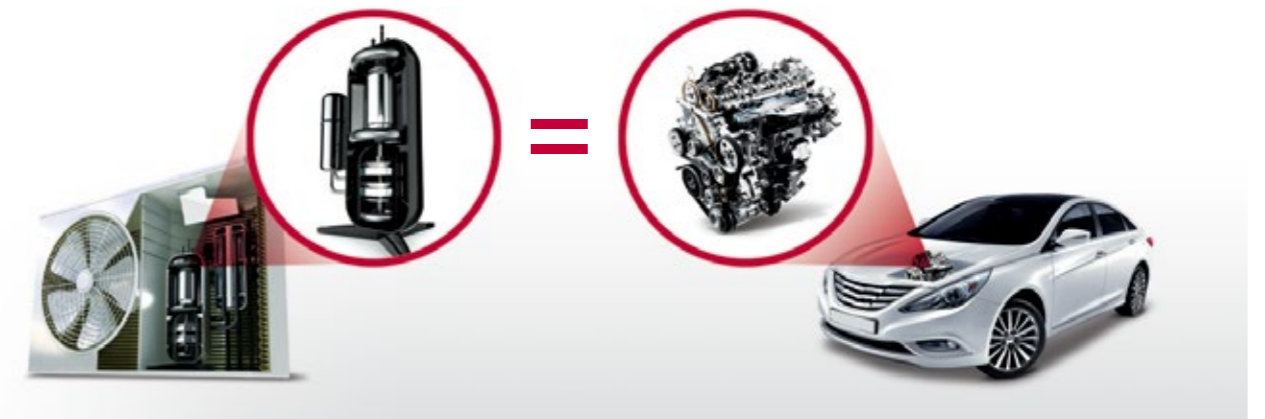

• Benefit & Verification

Reliable Air Conditioner

Product safety is emphasized by offering a 10-year warranty on the compressor to reassure customers about product durability.



Verification

TUV Rheinland, Long Term Accelerated-reliability Test & High Marginal Test

- ※ Long Term Accelerated-Reliability test
 LG's unique testing method with reinforced operating condition for a product life assurance to test and determine the product life cycle in a short period of time by accelerating the life cycle.
- ※ High Marginal Test
 Test method to secure durability in various adverse conditions that may occur in the field by performing comp reliability test against higher pressure and temperature than the designed range of pressure and temperature which the comp operates in.
- ※ Verification obtained from TUV Rheinland for 10-year product life cycle.



EXTREME DURABILITY



Gold Fin™

The Gold Fin™ coating protects the surface of the heat exchanger from unnecessary wear and corrosion.

※ Specifications may vary for each model.
 ※ Depending on the experimental conditions.

• How It Works

Corrosion-resistant protective layer

The gold-colored special coating on the fin of the heat exchanger prevents corrosion, extending the life of the unit.

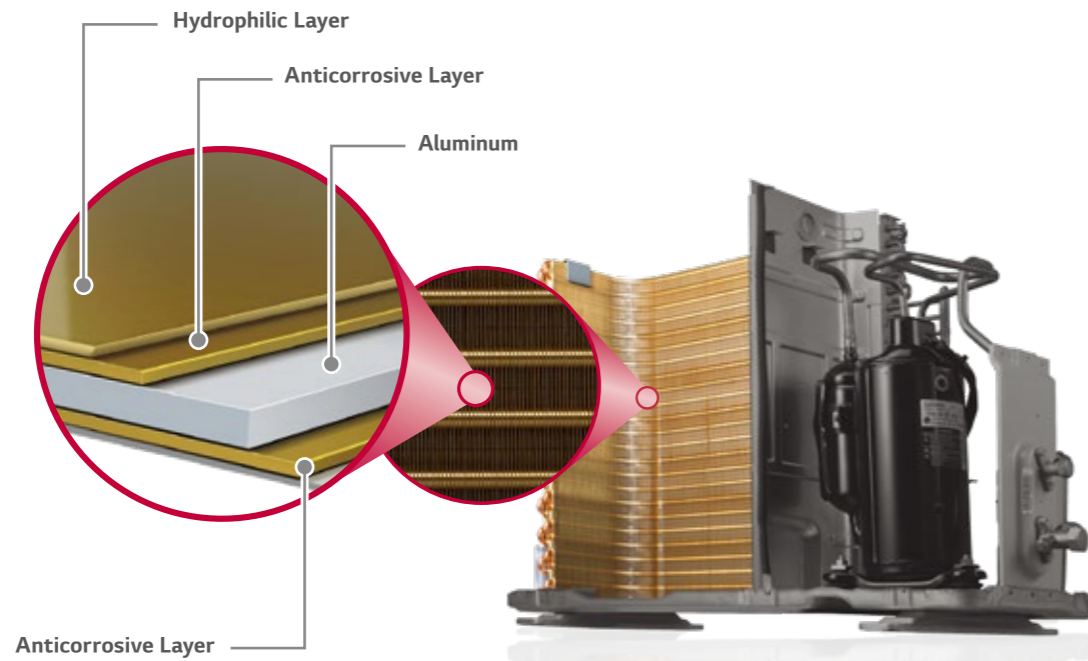

• Test Result

Conventional Fin



Gold Fin™



* Test result: 360 hrs. after being exposed to sodium chloride.

COMFORT



Comfort Air (Indirect Cooling)

LG provides pure hygienic and temperature regulated atmosphere surrounding your living space. An automatic vane angle adjustment sets perfect vane angle and air volume.

※ Specifications may vary for each model.

• Concept

Comfort Air changes the air flow angle to ensure that air is directed away from occupants to promote more comfortable environments optimized for sleeping and more.

• How It Works

Control Panel



Comfort Vane

This option conveniently sets an AC's louvers to a preset position so that outflowing air is directed away from a room's occupants.

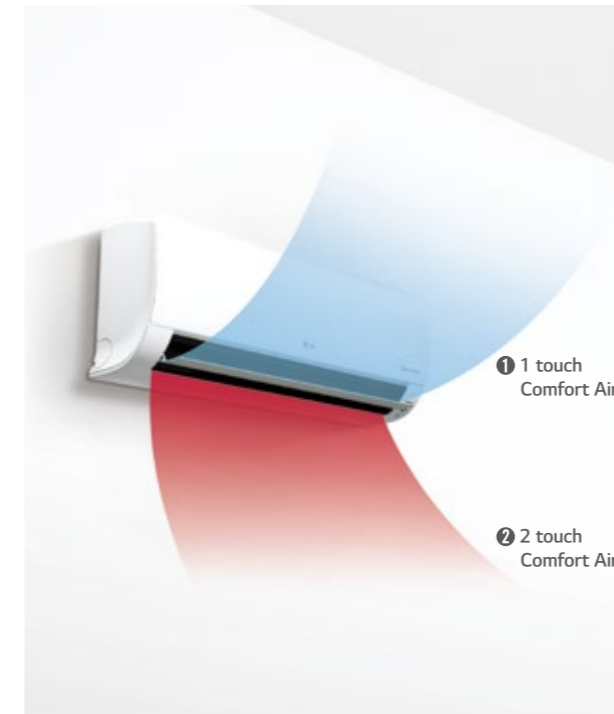

Scene 1: Inclines to a maximum 80° angle.

Sets vane angle to highest position : Optimized for gentle airflow cooling.

Indoor Unit Display

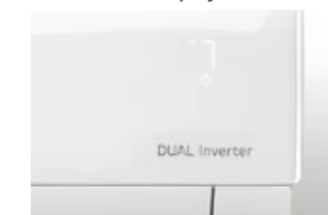

Remote Controller Display



Scene 2: Declines to a maximum 10° angle.

Sets vane angle to lowest position : Optimized for gentle airflow heating.

Indoor Unit Display

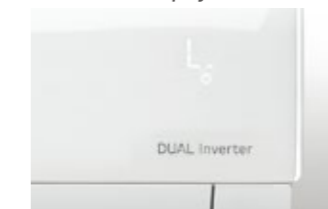

Remote Controller Display



COMFORT



Low Noise

LG Air Conditioners operate at 19dB low noise level, moreover provide healthy soft air by just 1 touch.

※ Specifications may vary for each model.

• How It Works

LG's Unique Skew Fan

By minimizing the surface pressure of the fan blade when in contact with the air, the noise produced by the air conditioning unit is reduced to a remarkably low level.



15%
Tilted
Stabilizer

BLDC Fan Motor

With strong torque and powerful ND magnetism as well as precise speed control of 13 different steps for smooth operation, the BLDC motor provides substantial air volume and high static pressure, while keeping electrical and mechanical noise lower, and making high-speed operation available.

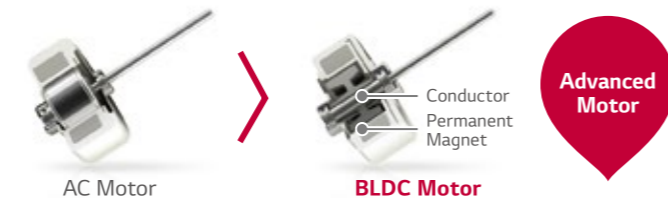

Advanced
Motor

- Low Efficiency.
- Heat Problem during overhauling.
- Difficult precise speed control.
- Low Electric and mechanical noise.
- Precise speed control durable.

ALVC (Active Low Vibration Control)

A speed-error component estimates the load to compensate for imbalances, which are the primary causes of vibration and noise, enabling the rotation of the motor without vibration at low Hz levels.

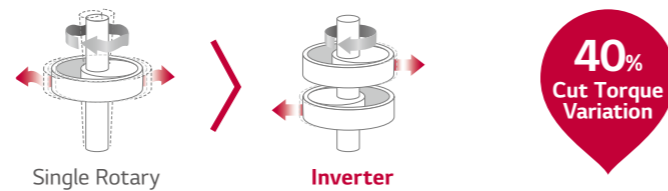

40%
Cut Torque
Variation

• Benefit

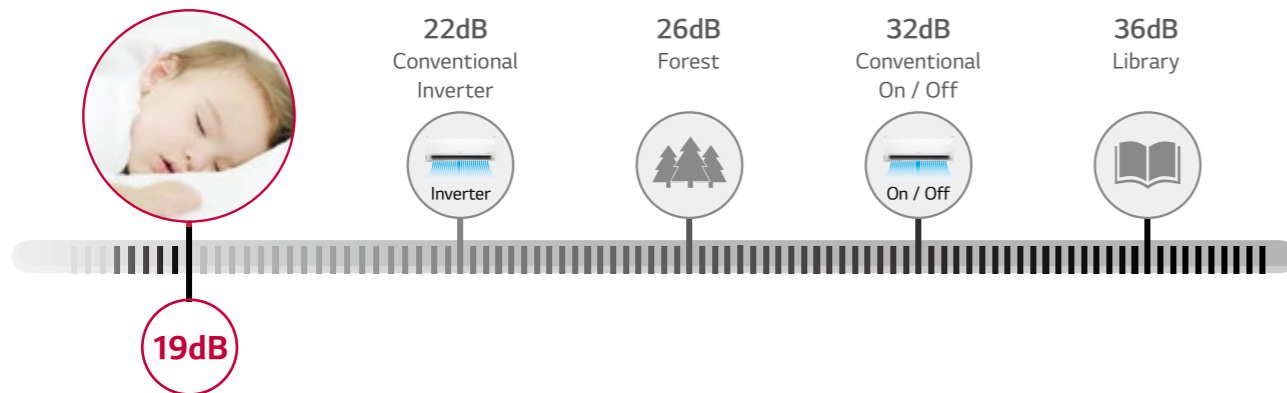

COMFORT



Silent Mode

Silent mode ensures a tranquil and serene experience for the user by reducing noise disturbances while you are resting.

※ Specifications may vary for each model.

※ Depending on the experimental conditions.

※ When connected to Multi Outdoor unit, Silent Mode is working by simply setting the dip switch on the PCB of the outdoor unit.

• How It Works

In Silent Mode, the overall sound level of the outdoor unit drops by up to 3dB and the sound level of the indoor unit also decreases.

Press the Silent Button

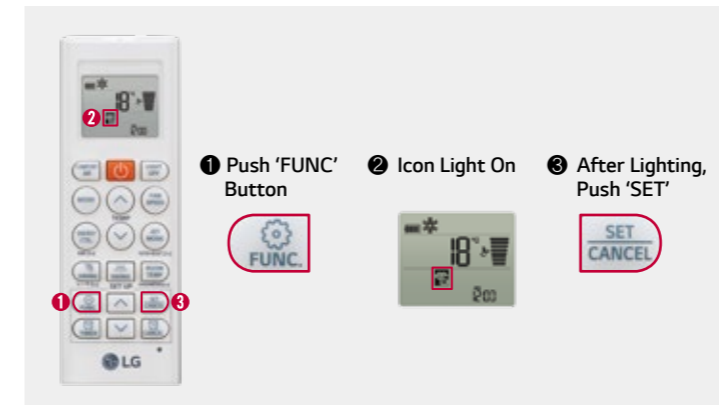

Controls the Outdoor Compressor



• Test Result

Noise Comparison Graph

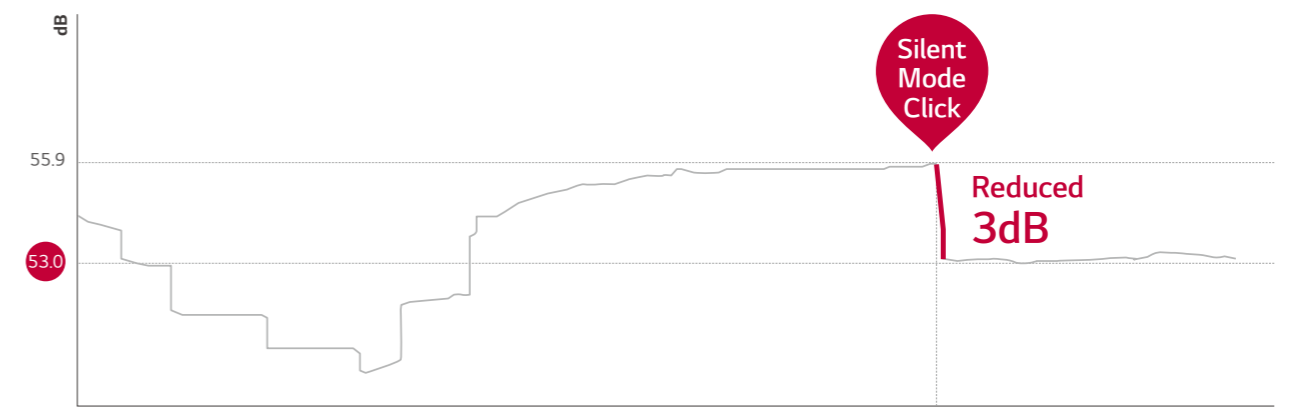

※ Test Conditions
Spec : Selecting Silent Mode reduces the noise of an outdoor fan unit by 3dB.
Assessment : 36.2 dB emitted from center/side of unit at a distance of 1m.

COMFORT

Quick & Easy Installation

LG air conditioner is designed for an easy and efficient installation, making possible to install several units in a short period of time.

※ Specifications may vary for each model.

• Concept

By reducing the manpower and time required for installation, it is now possible to install more units in less time.

• How It Works

One Simple Packing Box

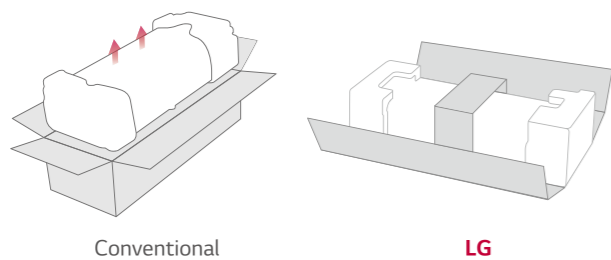

Installation Plate Improvement

LG's installation plate is larger and customized to reduce installation time.

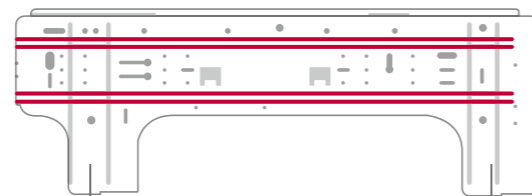

Installation Support Clip

A support clip creates adequate space between the wall and the unit for easier installation.

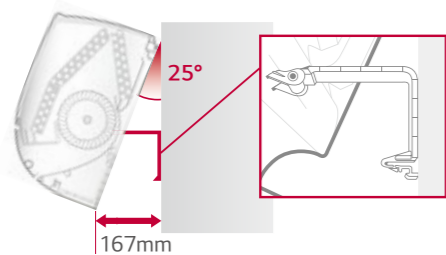

Wider Tubing Space

The space provided for tubing facilitates the whole installation process and hides the unorganized parts, making it appear clean and tidy.

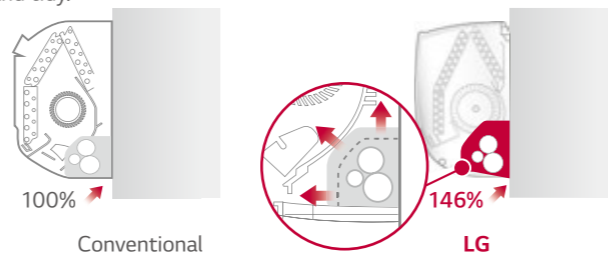

Detachable Bottom Cover

The air conditioner's bottom cover is detachable for easier installation and access.

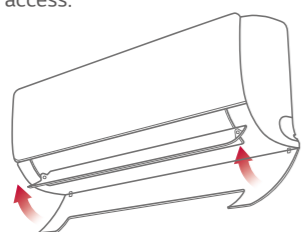

Quick button for running test

The test button is conveniently located and easy to find.

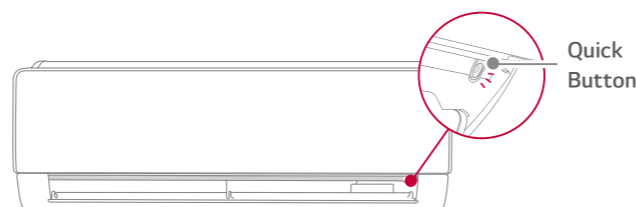

ARTCOOL GALLERY



NEW



LG participates in the ECP programme for EUROVENT AC program. Check ongoing validity of certification : www.eurovent-certification.com



• Single Combination

	UNIT			9K			12K		
	INDOOR			A09FT NSF			A12FT NSF		
Capacity	Cooling	Min / Rated / Max	W	890 / 2,500 / 3,700			890 / 3,500 / 4,040		
	Heating	Min / Rated / Max	W	890 / 3,300 / 4,100			890 / 4,000 / 5,100		
	Heating -7°C	Rated	W	3200			3500		
Power Input	Cooling	Rated	W	658			1050		
	Heating	Rated	W	831			1108		
EER			W / W	3.8			3.33		
S.E.E.R.				6.8			6.6		
P design C			kW	2.5			3.5		
COP			W / W	3.97			3.61		
S.C.O.P. (Average / Warmer)				4.0 / 4.6			4.0 / 4.6		
P design H (Average / Warmer)			kW	2.7 / 1.5			2.7 / 1.5		
Energy Label	Cooling			A++			A++		
(A+++ to D Scale)	Heating (Average / Warmer)			A+ / A++			A+ / A++		
Annual Energy Consumption	Cooling		kWh	129			186		
	Heating (Average / Warmer)		kWh	945 / 457			945 / 457		
Sound Pressure	Cooling	S / L / M / H	dB(A)	27 / 35 / 39 / 45			27 / 35 / 39 / 45		
	Heating	L / M / H	dB(A)	35 / 39 / 45			35 / 39 / 45		
Sound Power	Cooling		dB(A)	60			60		
	Power								
Air Flow Rate	Cooling	S / L / M / H	m ³ / min	- / 6.0 / 7.6 / 9.0			- / 6.0 / 7.6 / 9.0		
	Max (Power)		m ³ / min	10.0			10.0		
Dehumidification Rate	Heating	L / M / H	m ³ / min	6.1 / 7.8 / 9.3			6.1 / 7.8 / 9.3		
			l/h	1.1			1.3		
Running Current	Cooling	Rated	A	3.2			4.9		
		Max	A	6.0			6.0		
	Heating	Rated	A	4.1			5.1		
		Max	A	7.0			7.0		
Starting Current	Cooling / Heating	Rated	A	3.2 / 4.1			4.9 / 5.1		
Power Supply			∅ V, Hz	1, 220-240, 50			1, 220-240, 50		
Circuit Breaker			A	15			15		
Power Supply Cable			N x mm ²	3 x 1.0			3 x 1.0		
Power & Transmission Cable			N x mm ²	4 x 1.0 (Including Earth)			4 x 1.0 (Including Earth)		
Dimension			mm	600 x 600 x 146			600 x 600 x 146		
Net Weight			kg	14.4			14.4		
Fan Motor Output			W	16.7			16.7		
Operation Range	Cooling	Min / Max	°CDB	-10 / 48			-10 / 48		
	Heating	Min / Max	°CDB	-10 / 24			-10 / 24		
Sound Pressure	Cooling	High	dB(A)	51			51		
	Heating	High	dB(A)	51			51		
Sound Power	Cooling	High	dB(A)	65			65		
	High			35			35		
Piping	Length (Odu / ldu)	Min / Max	m	3 / 20			3 / 20		
	Elevation (Odu / ldu)	Max	m	10			10		
Piping Connection	Liquid	OD (Outside)	mm (inch)	6.35 (1/4)			6.35 (1/4)		
	Gas	OD (Outside)	mm (inch)	9.52 (3/8)			9.52 (3/8)		
Drain Hose Size		OD (Outside)	mm (inch)	21.5 (27/32)			21.5 (27/32)		
	Type			R32			R32		
Refrigerant	Charge at 7.5m		kg	0.800			0.800		
	Additional charge		t-CO ₂ eq	0.540			0.540		
	GWP		g/m	20			20		
Fan Motor Output			W	43			43		
Compressor Type				Twin Rotary			Twin Rotary		
Net Weight			kg	34.4			34.4		
Dimension			mm	770 x 545 x 288			770 x 545 x 288		

※ This product contains Fluorinated greenhouse gases (R32).

※ S : Sleep / L : Low / M : Medium / H : High

※ GWP : Global warming potential

※ t-CO₂eq : F-gas(kg)*GWP/1000

※ Specification, design and feature are subject to change without prior notice.

ARTCOOL MIRROR



Dual Inverter COMPRESSOR
EUROVENT CERTIFIED PERFORMANCE
 LG participates in the ECP programme for EUROVENT AC program. Check ongoing validity of certification : www.eurovent-certification.com

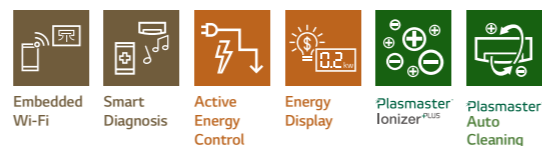

• Single Combination

UNIT				9K	12K	18K	24K
INDOOR				AC09BQ NSJ	AC12BQ NSJ	AC18BQ NSK	AC24BQ NSK
Capacity	Cooling	Min / Rated / Max	W	890 / 2,500 / 3,700	890 / 3,500 / 4,040	900 / 5,000 / 5,500	900 / 6,600 / 7,420
	Heating	Min / Rated / Max	W	890 / 3,300 / 4,100	890 / 4,000 / 5,100	900 / 5,800 / 6,400	900 / 7,500 / 8,640
	Heating -7°C	Rated	W	2,600	3,000	4,200	6,000
Power Input	Cooling	Rated	W	656	1,080	1,562	2,164
	Heating	Rated	W	800	1,050	1,611	2,238
EER			W / W	3.81	3.24	3.20	3.05
S.E.E.R.				7.0	6.6	7.0	6.9
P design C			kW	2.5	3.5	5.0	6.6
COP			W / W	4.13	3.81	3.60	3.35
S.C.O.P. (Average / Warmer)				4.0 / 4.9	4.0 / 4.9	4.3 / 5.3	4.3 / 5.3
P design H (Average / Warmer)			kW	2.5 / 1.3	2.5 / 1.3	3.9 / 2.1	5.0 / 2.7
Energy Label (A+++ to D Scale)	Cooling			A++	A++	A++	A++
	Heating (Average / Warmer)			A+ / A++	A+ / A++	A+ / A+++	A+ / A+++
Annual Energy Consumption	Cooling		kWh	125	186	250	335
	Heating (Average / Warmer)		kWh	875 / 371	875 / 371	1270 / 555	1628 / 713
Sound Pressure	Cooling	S / L / M / H	dB(A)	19 / 27 / 35 / 41	19 / 27 / 35 / 41	31 / 34 / 39 / 44	31 / 34 / 42 / 47
	Heating	L / M / H	dB(A)	27 / 35 / 41	27 / 35 / 41	34 / 39 / 44	34 / 42 / 47
Sound Power	Cooling	Power	dB(A)	59	59	60	65
	Heating	S / L / M / H	m³ / min	3.0 / 4.2 / 7.5 / 10.0	3.0 / 4.2 / 7.5 / 10.0	8.0 / 10.5 / 13.0 / 14.5	8.0 / 10.5 / 13.1 / 16.1
Air Flow Rate	Cooling	Max (Power)	m³ / min	12.5	12.5	15.5	20.0
	Heating	L / M / H	m³ / min	5.6 / 7.2 / 10.0	5.6 / 7.2 / 10.0	11.0 / 13.5 / 16.0	10.5 / 13.1 / 16.1
Dehumidification Rate			l/h	1.1	1.3	1.8	2.5
		Rated	A	3.3	4.7	6.9	9.8
Running Current	Cooling	Max	A	6.0	6.0	9.0	14.0
	Heating	Rated	A	4.0	4.7	7.1	10.4
		Max	A	7.0	7.0	9.5	14.0
Starting Current	Cooling / Heating	Rated	A	3.3 / 4.0	4.7 / 4.7	6.9 / 7.1	9.8 / 10.4
Power Supply			Ø, V, Hz	1, 220-240, 50	1, 220-240, 50	1, 220-240, 50	1, 220-240, 50
Circuit Breaker			A	15	15	20	25
Power Supply Cable			N x mm²	3 x 1.0	3 x 1.0	3 x 1.5	3 x 2.5
Power & Transmission Cable			N x mm²	4 x 1.0	4 x 1.0	4 x 1.0	4 x 1.0
Dimension			mm	837 x 308 x 192	837 x 308 x 192	998 x 345 x 212	998 x 345 x 212
Net Weight			kg	9.9	9.9	12.8	13.5
Fan Motor Output			W	30	30	30	60
OUTDOOR				AC09BQ UA3	AC12BQ UA3	AC18BQ UL2	AC24BQ U24
Operation Range	Cooling	Min / Max	°CDB	-10 / 48	-10 / 48	-15 / 48	-15 / 48
	Heating	Min / Max	°CDB	-10 / 24	-10 / 24	-10 / 24	-10 / 24
Sound Pressure	Cooling	High	dB(A)	48	48	53	54
	Heating	High	dB(A)	50	50	55	57
Sound Power	Cooling	High	dB(A)	65	65	65	70
	Heating	High	dB(A)	27	27	35	50
Air Flow Rate	Length (Odu / Idu)	Min / Max	m	3 / 15	3 / 15	3 / 20	3 / 30
	Elevation (Odu / Idu)	Max	m	7	7	10	15
Piping Connection	Liquid	OD (Outside)	mm (inch)	6.35 (1/4)	6.35 (1/4)	6.35 (1/4)	6.35 (1/4)
	Gas	OD (Outside)	mm (inch)	9.52 (3/8)	9.52 (3/8)	12.7 (1/2)	15.88 (5/8)
Drain Hose Size		OD (Outside)	mm (inch)	21.5 (0.85)	21.5 (0.85)	21.5 (0.85)	21.5 (0.85)
Refrigerant	Type			R32	R32	R32	R32
	Charge at 7.5m		kg	0.700	0.700	1.000	1.100
	Additional charge		t-CO ₂ eq	0.473	0.473	0.675	0.743
	GWP		g/m	20	20	20	20
Fan Motor Output			W	43	43	43	85
Compressor Type				Twin Rotary	Twin Rotary	Twin Rotary	Twin Rotary
Net Weight			kg	26.0	26.0	35.2	46.4
Dimension			mm	717 x 495 x 230	717 x 495 x 230	770 x 545 x 288	870 x 650 x 330

※ This product contains Fluorinated greenhouse gases (R32).
 ※ S : Sleep / L : Low / M : Medium / H : High
 ※ GWP : Global warming potential
 ※ t-CO₂eq : F-gas(kg)*GWP/1000
 ※ Specification, design and feature are subject to change without prior notice.

ARTCOOL SILVER



Dual Inverter COMPRESSOR
EUROVENT CERTIFIED PERFORMANCE
 LG participates in the ECP programme for EUROVENT AC program. Check ongoing validity of certification : www.eurovent-certification.com

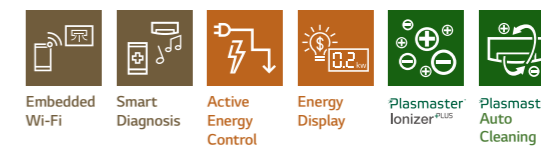

• Single Combination

UNIT				9K	12K	18K
INDOOR				AC09SQ NSJ	AC12SQ NSJ	AC18SQ NSK
Capacity	Cooling	Min / Rated / Max	W	890 / 2,500 / 3,700	890 / 3,500 / 4,040	900 / 5,000 / 5,500
	Heating	Min / Rated / Max	W	890 / 3,300 / 4,100	890 / 4,000 / 5,100	900 / 5,800 / 6,400
	Heating -7°C	Rated	W	2,600	3,000	4,200
Power Input	Cooling	Rated	W	656	1,080	1,562
	Heating	Rated	W	800	1,050	1,611
EER			W / W	3.81	3.24	3.20
S.E.E.R.				7.0	6.6	7.0
P design C			kW	2.5	3.5	5.0
COP			W / W	4.13	3.81	3.60
S.C.O.P. (Average / Warmer)				4.0 / 4.9	4.0 / 4.9	4.3 / 5.3
P design H (Average / Warmer)			kW	2.5 / 1.3	2.5 / 1.3	3.9 / 2.1
Energy Label (A+++ to D Scale)	Cooling			A++	A++	A++
	Heating (Average / Warmer)			A+ / A++	A+ / A++	A+ / A+++
Annual Energy Consumption	Cooling		kWh	125	186	250
	Heating (Average / Warmer)		kWh	875 / 386	875 / 386	1,270 / 555
Sound Pressure	Cooling	S / L / M / H	dB(A)	19 / 27 / 35 / 41	19 / 27 / 35 / 41	31 / 34 / 39 / 44
	Heating	L / M / H	dB(A)	27 / 35 / 41	27 / 35 / 41	34 / 39 / 44
Sound Power	Cooling	Power	dB(A)	59	59	60
	Heating	S / L / M / H	m³ / min	3.0 / 4.2 / 7.5 / 10.0	3.0 / 4.2 / 7.5 / 10.0	8.0 / 10.5 / 13.0 / 14.5
Air Flow Rate	Cooling	Max (Power)	m³ / min	12.5	12.5	15.5
	Heating	L / M / H	m³ / min	5.6 / 7.2 / 10.0	5.6 / 7.2 / 10.0	11.0 / 13.5 / 16.0
Dehumidification Rate			l/h	1.1	1.3	1.8
		Rated	A	3.3	4.7	6.9
Running Current	Cooling	Max	A	6.0	6.0	9.0
	Heating	Rated	A	4.0	4.7	7.1
		Max	A	7.0	7.0	9.5
Starting Current	Cooling / Heating	Rated	A	3.3 / 4.0	4.7 / 4.7	6.9 / 7.1
Power Supply			Ø, V, Hz	1, 220-240, 50	1, 220-240, 50	1, 220-240, 50
Circuit Breaker			A	15	15	20
Power Supply Cable			N x mm²	3 x 1.0	3 x 1.0	3 x 1.5
Power & Transmission Cable			N x mm²	4 x 1.0	4 x 1.0	4 x 1.0
Dimension			mm	837 x 308 x 192	837 x 308 x 192	998 x 345 x 212
Net Weight			kg	9.9	9.9	12.8
Fan Motor Output			W	30	30	30
OUTDOOR				AC09BQ UA3	AC12BQ UA3	AC18BQ UL2
Operation Range	Cooling	Min / Max	°CDB	-10 / 48	-10 / 48	-15 / 48
	Heating	Min / Max	°CDB	-10 / 24	-10 / 24	-10 / 24
Sound Pressure	Cooling	High	dB(A)	48	48	53
	Heating	High	dB(A)	50	50	55
Sound Power	Cooling	High	dB(A)	65	65	65
	Heating	High	dB(A)	27	27	35
Piping	Length (Odu / Idu)	Min / Max	m	3 / 15	3 / 15	3 / 20
	Elevation (Odu / Idu)	Max	m	7	7	10
Piping Connection	Liquid	OD (Outside)	mm (inch)	6.35 (1/4)	6.35 (1/4)	6.35 (1/4)
	Gas	OD (Outside)	mm (inch)	9.52 (3/8)	9.52 (3/8)	12.7 (1/2)
Drain Hose Size		OD (Outside)	mm (inch)	21.5 (0.85)	21.5 (0.85)	21.5 (0.85)
Refrigerant	Type			R32	R32	R32
	Charge at 7.5m		kg	0.700	0.700	1.000
	Additional charge		t-CO ₂ eq	0.473	0.473	0.675
	GWP		g/m	20	20	20
Fan Motor Output			W	43	43	43
Compressor Type				Twin Rotary	Twin Rotary	Twin Rotary
Net Weight			kg	26.0	26.0	35.2
Dimension			mm	717 x 495 x 230	717 x 495 x 230	770 x 545 x 288

※ This product contains Fluorinated greenhouse gases (R32).
 ※ S : Sleep / L : Low / M : Medium / H : High
 ※ GWP : Global warming potential
 ※ t-CO₂eq : F-gas(kg)*GWP/1000
 ※ Specification, design and feature are subject to change without prior notice.

PRESTIGE



NEW



LG participates in the ECP programme for EUROVENT AC program. Check ongoing validity of certification: www.eurovent-certification.com

Embedded Wi-Fi	Smart Diagnosis	Active Energy Control	Energy Display	Plasmaster Ionizer PLUS	Dual Protection Filter	Plasmaster Auto Cleaning
Jet Cool	4 Way Swing	Fast Heating	Gold Fin™	Low Noise 19dB	Silent Mode	Quick & Easy Installation

• Single Combination

UNIT				9K				12K			
INDOOR				F09MT NSM				F12MT NSM			
Capacity	Cooling	Min / Rated / Max	W	300 / 2,500 / 4,000			300 / 3,500 / 4,250				
	Heating	Min / Rated / Max	W	300 / 3,200 / 6,900			300 / 4,000 / 7,320				
	Heating -7°C	Rated	W	4,300			4,700				
Power Input	Cooling	Rated	W	490			833				
	Heating	Rated	W	593			785				
EER			W / W	5.1			4.2				
S.E.E.R.				9.4			9.1				
P design C			kW	2.5			3.5				
COP			W / W	5.4			5.1				
S.C.O.P. (Average / Warmer)				5.1 / -			5.1 / -				
P design H (Average / Warmer)			kW	3.7 / -			3.8 / -				
Energy Label (A+++ to D Scale)	Cooling			A+++			A+++				
	Heating (Average / Warmer)			A+++ / -			A+++ / -				
Annual Energy Consumption	Cooling		kWh	93			135				
	Heating (Average / Warmer)		kWh	1,016 / -			1,043 / -				
Sound Pressure	Cooling	S / L / M / H	dB(A)	19 / 27 / 35 / 40			19 / 27 / 35 / 40				
	Heating	L / M / H	dB(A)	27 / 35 / 40			27 / 35 / 40				
Sound Power	Cooling		dB(A)	60			60				
	Heating		dB(A)	60			60				
Air Flow Rate	Cooling	S / L / M / H	m³ / min	6.6 / 8.7 / 11.1 / 12.4			6.6 / 8.7 / 11.1 / 12.4				
	Heating	Max (Power)	m³ / min	15.5			15.5				
Dehumidification Rate	Cooling	L / M / H	m³ / min	8.7 / 11.1 / 14.3			8.7 / 11.1 / 14.3				
	Heating		l/h	1.7			1.7				
Running Current	Cooling	Rated	A	3.8			6.1				
		Max	A	8.1			8.1				
	Heating	Rated	A	4.6			5.8				
Starting Current	Max	A	8.8			8.8					
Power Supply	Cooling / Heating	Rated	A	3.8 / 4.6			6.1 / 5.8				
Power Supply Cable			∅, V, Hz	1, 220-240, 50			1, 220-240, 50				
Circuit Breaker			A	15			15				
Power & Transmission Cable			N x mm²	3 x 1.0			3 x 1.0				
Dimension			N x mm²	4 x 1.0 (Including Earth)			4 x 1.0 (Including Earth)				
Net Weight			mm	875 x 295 x 235			875 x 295 x 235				
Fan Motor Output			kg	11.0			11.0				
			W	30			30				
OUTDOOR				F09MT U24				F12MT U24			
Operation Range	Cooling	Min / Max	°CDB	-10 / 48			-10 / 48				
	Heating	Min / Max	°CDB	-25 / 24			-25 / 24				
Sound Pressure	Cooling	High	dB(A)	48			48				
	Heating	High	dB(A)	50			50				
Sound Power	Cooling	High	dB(A)	65			65				
	Heating	High	dB(A)	65			65				
Air Flow Rate	Cooling	High	m³ / min	49			49				
	Heating	High	m³ / min	49			49				
Piping	Length (Odu / Idu)	Min / Max	m	3 / 20			3 / 20				
	Elevation (Odu / Idu)	Max	m	10			10				
Piping Connection	Liquid	OD (Outside)	mm (inch)	6.35 (1/4)			6.35 (1/4)				
	Gas	OD (Outside)	mm (inch)	9.52 (3/8)			9.52 (3/8)				
Drain Hose Size		OD (Outside)	mm (inch)	21.5 (27/32)			21.5 (27/32)				
Refrigerant	Type			R32			R32				
	Charge at 7.5m		kg	1.000			1.000				
	Additional charge		t-CO ₂ eq	0.675			0.675				
	GWP		g/m	20			20				
Fan Motor Output			W	85			85				
Compressor Type				Twin Rotary			Twin Rotary				
Net Weight			kg	43			43				
Dimension			mm	870 x 650 x 330			870 x 650 x 330				

※ This product contains Fluorinated greenhouse gases (R32).
 ※ S : Sleep / L : Low / M : Medium / H : High
 ※ GWP : Global warming potential
 ※ t-CO₂eq : F-gas(kg)*GWP/1000
 ※ Specification, design and feature are subject to change without prior notice.

DUALCOOL WITH AIR PURIFICATION



NEW



LG participates in the ECP programme for EUROVENT AC program. Check ongoing validity of certification: www.eurovent-certification.com

Embedded Wi-Fi	Voice Control	Active Energy Control	Energy Display	Auto Cleaning	PM 1.0 SENSOR
Jet Cool	4 Way Swing	Fast Heating	Gold Fin™	Comfort Air	Quick & Easy Installation

• Single Combination

UNIT				9K				12K			
INDOOR				AP09RT NSJ				AP12RT NSJ			
Capacity	Cooling	Min / Rated / Max	W	890 / 2,500 / 3,700			890 / 3,500 / 4,000				
	Heating	Min / Rated / Max	W	890 / 3,300 / 4,100			890 / 4,000 / 4,700				
	Heating -7°C	Rated	W	2,600			3,000				
Power Input	Cooling	Rated	W	710			1,160				
	Heating	Rated	W	850			1,130				
EER			W/W	3.52			3.02				
S.E.E.R.				6.6			6.2				
P design C			kW	2.5			3.5				
COP			W/W	3.88			3.54				
S.C.O.P. (Average / Warmer)				4.0 / 5.0			4.0 / 5.0				
P design H (Average / Warmer)			kW	2.5 / 1.4			2.5 / 1.4				
Energy Label (A++ to D Scale)	Cooling			A++			A++				
	Heating (Average / Warmer)			A+ / A++			A+ / A++				
Annual Energy Consumption	Cooling		kWh	133			198				
	Heating (Average / Warmer)		kWh	875 / 393			875 / 393				
Sound Pressure	Cooling	S / L / M / H	dB(A)	21 / 27 / 35 / 42			21 / 27 / 35 / 42				
	Heating	L / M / H	dB(A)	30 / 35 / 41			30 / 35 / 41				
Sound Power	Cooling		dB(A)	59			59				
	Heating		dB(A)	59			59				
Air Flow Rate	Cooling	S / L / M / H	m³/min	3.0 / 4.2 / 6.6 / 10.0			3.0 / 4.2 / 6.6 / 10.0				
	Heating	Max (Power)	m³/min	11.0			11.0				
Dehumidification Rate	Cooling	L / M / H	m³/min	4.2 / 6.6 / 10.0			4.2 / 6.6 / 10.0				
	Heating		l/h	1.1			1.3				
Running Current	Cooling	Rated	A	3.5			5.2				
		Max	A	6.0			6.2				
	Heating	Rated	A	4.0			5.1				
Starting Current	Max	A	7.0			7.0					
Power Supply	Cooling / Heating	Rated	A	3.5 / 4.0			5.2 / 5.1				
Power Supply Cable			∅, V, Hz	1 / 220-240 / 50			1 / 220-240 / 50				
Circuit Breaker			A	15			15				
Power & Transmission Cable			N x mm²	3 x 1.0			3 x 1.0				
Dimension			N x mm²	4 x 1.0			4 x 1.0				
Net Weight			mm	857 x 348 x 189			857 x 348 x 189				
Fan Motor Output			kg	9.5			9.5				
			W	30			30				
OUTDOOR				AP09RT UA3				AP12RT UA3			
Operation Range	Cooling	Min / Max	°CDB	-10 / 48			-10 / 48				
	Heating	Min / Max	°CDB	-10 / 24			-10 / 24				
Sound Pressure	Cooling	High	dB(A)	48			48				
	Heating	High	dB(A)	50			50				
Sound Power	Cooling	High	dB(A)	65			65				
	Heating	High	dB(A)	65			65				
Air Flow Rate	Cooling	High	m³/min	27			27				
	Heating	High	m³/min	27			27				
Piping	Length (Odu/Idu)	Min / Max	m	3 / 15			3 / 15				
	Elevation (Odu/Idu)	Max	m	7			7				
Piping Connection	Liquid	OD (Outside)	mm (inch)	6.35 (1/4)			6.35 (1/4)				
	Gas	OD (Outside)	mm (inch)	9.52 (3/8)			9.52 (3/8)				
Drain Hose Size		OD (Outside)	mm (inch)	21.5 (0.85)			21.5 (0.85)				
Refrigerant	Type			R32			R32				
	Charge at 7.5m		kg	0.700			0.700				
	Additional charge		t-CO ₂ eq	0.473			0.473				
	GWP		g/m	20			20				
Fan Motor Output			W	43			43				
Compressor Type				Twin Rotary			Twin Rotary				
Net Weight			kg	26			26				
Dimension			mm	717 x 495 x 230			717 x 495 x 230				

※ This product contains Fluorinated greenhouse gases (R32).
 ※ S : Sleep / L : Low / M : Medium / H : High
 ※ GWP : Global warming potential
 ※ t-CO₂eq : F-gas(kg)*GWP/1000
 ※ Specification, design and feature are subject to change without prior notice.

DELUXE



LG participates in the ECP programme for EUROVENT AC program. Check ongoing validity of certification: www.eurovent-certification.com

Embedded Wi-Fi

Smart Diagnosis

Active Energy Control

Energy Display

Plasmaster Ionizer^{PLUS}

Plasmaster Auto Cleaning

Jet Cool

4 Way Swing

Fast Heating

Gold Fin™

Comfort Air

Low Noise 19dB (9k, 12k)

Silent Mode

Quick & Easy Installation

• Single Combination

UNIT				9K	12K	18K	24K
INDOOR				DC09RQ NSJ	DC12RQ NSJ	DC18RQ NSK	DC24RQ NSK
Capacity	Cooling	Min / Rated / Max	W	890 / 2,500 / 3,700	890 / 3,500 / 4,040	900 / 5,000 / 5,500	900 / 6,600 / 7,420
	Heating	Min / Rated / Max	W	890 / 3,200 / 5,000	890 / 4,000 / 6,000	900 / 5,800 / 6,400	900 / 7,500 / 8,640
	Heating -7°C	Rated	W	3,200	3,500	4,200	6,000
Power Input	Cooling	Rated	W	572	933	1,562	2,164
	Heating	Rated	W	711	976	1,611	2,238
EER			W/W	4.37	3.75	3.20	3.05
S.E.E.R.				7.9	7.6	7.0	6.9
P design C			kW	2.5	3.5	5.0	6.6
COP			W/W	4.5	4.1	3.60	3.35
S.C.O.P. (Average / Warmer)				4.6 / 5.4	4.6 / 5.4	4.3 / 5.3	4.3 / 5.3
P design H (Average / Warmer)			kW	2.8 / 1.5	2.9 / 1.5	3.9 / 2.1	5.0 / 2.7
Energy Label (A+++ to D Scale)	Cooling			A++	A++	A++	A++
	Heating (Average / Warmer)			A++ / A+++	A++ / A+++	A+ / A+++	A+ / A+++
Annual Energy Consumption	Cooling		kWh	111	161	250	335
	Heating (Average / Warmer)		kWh	852 / 389	883 / 389	1,270 / 555	1,628 / 713
Sound Pressure	Cooling	S / L / M / H	dB(A)	19 / 27 / 37 / 42	19 / 27 / 37 / 42	31 / 34 / 39 / 44	31 / 34 / 42 / 47
	Heating	L / M / H	dB(A)	27 / 37 / 42	27 / 37 / 42	34 / 39 / 44	34 / 42 / 47
Sound Power	Cooling	Power	dB(A)	60	60	60	65
	Heating	S / L / M / H	m³/min	3.5 / 5.5 / 9.0 / 11.0	3.5 / 5.5 / 9.0 / 11.0	8.0 / 10.5 / 13.0 / 14.5	8.0 / 10.5 / 13.1 / 16.1
Air Flow Rate	Cooling	Max (Power)	m³/min	13.0	13.0	15.5	20.0
	Heating	L / M / H	m³/min	6.5 / 9.0 / 11.0	6.5 / 9.0 / 11.0	11.0 / 13.5 / 16.0	10.5 / 13.1 / 16.1
Dehumidification Rate			l/h	1.1	1.3	1.8	2.5
		Rated	A	2.5	4.0	6.9	9.8
Running Current	Cooling	Max	A	6.0	6.0	9.0	14.0
	Heating	Rated	A	3.2	4.3	7.1	10.4
		Max	A	7.0	7.0	9.5	14.0
Starting Current	Cooling / Heating	Rated	A	2.5 / 3.2	4.0 / 4.3	6.9 / 7.1	9.8 / 10.4
Power Supply			Ø V, Hz	1, 220-240, 50	1, 220-240, 50	1, 220-240, 50	1, 220-240, 50
Circuit Breaker			A	15	15	20	25
Power Supply Cable			N x mm²	3 x 1.0	3 x 1.0	3 x 1.5	3 x 2.5
Power & Transmission Cable			N x mm²	4 x 1.0	4 x 1.0	4 x 1.0	4 x 1.0
Dimension			mm	837 x 308 x 189	837 x 308 x 189	998 x 345 x 210	998 x 345 x 210
Net Weight			kg	9.1	9.1	11.9	12.7
Fan Motor Output			W	30	30	30	60
OUTDOOR				DC09RQ UL2	DC12RQ UL2	DC18RQ UL2	DC24RQ U24
Operation Range	Cooling	Min / Max	°CDB	-15 / 48	-15 / 48	-15 / 48	-15 / 48
	Heating	Min / Max	°CDB	-15 / 24	-15 / 24	-10 / 24	-10 / 24
Sound Pressure	Cooling	High	dB(A)	49	49	53	54
	Heating	High	dB(A)	51	51	55	57
Sound Power	Cooling	High	dB(A)	65	65	65	70
	Heating	High	dB(A)	65	65	65	70
Air Flow Rate	Cooling	High	m³/min	35	35	35	50
	Heating	High	m³/min	35	35	35	50
Piping	Length (Odu / ldu)	Min / Max	m	3 / 20	3 / 20	3 / 20	3 / 30
	Elevation (Odu / ldu)	Max	m	10	10	10	15
Piping Connection	Liquid	OD (Outside)	mm (inch)	6.35 (1/4)	6.35 (1/4)	6.35 (1/4)	6.35 (1/4)
	Gas	OD (Outside)	mm (inch)	9.52 (3/8)	9.52 (3/8)	12.7 (1/2)	15.88 (5/8)
Drain Hose Size		OD (Outside)	mm (inch)	21.5 (0.85)	21.5 (0.85)	21.5 (0.85)	21.5 (0.85)
	Type			R32	R32	R32	R32
Refrigerant	Charge at 7.5m		kg	0.800	0.800	1.000	1.100
	Additional charge		t-CO ₂ eq	0.540	0.540	0.675	0.743
	GWP		g/m	20	20	20	20
Fan Motor Output			W	675	675	675	675
Compressor Type				43	43	43	85
Net Weight			kg	34.1	34.1	34.4	46.0
Dimension			mm	770 x 545 x 288	770 x 545 x 288	770 x 545 x 288	870 x 650 x 330

※ This product contains Fluorinated greenhouse gases (R32).
 ※ S : Sleep / L : Low / M : Medium / H : High
 ※ GWP : Global warming potential
 ※ t-CO₂eq : F-gas(kg)*GWP/1000
 ※ Specification, design and feature are subject to change without prior notice.

DELUXE 2



NEW



LG participates in the ECP programme for EUROVENT AC program. Check ongoing validity of certification: www.eurovent-certification.com

Embedded Wi-Fi

Smart Diagnosis

Active Energy Control

Energy Display

Plasmaster Ionizer^{PLUS}

Plasmaster Auto Cleaning

Jet Cool

4 Way Swing

Fast Heating

Gold Fin™

Comfort Air

Low Noise 19dB (9k, 12k)

Silent Mode

Quick & Easy Installation

• Single Combination

UNIT				9K	12K
INDOOR				DC09RT NSJ	DC12RT NSJ
Capacity	Cooling	Min / Rated / Max	W	890 / 2,500 / 3,700	890 / 3,500 / 4,040
	Heating	Min / Rated / Max	W	890 / 3,300 / 4,100	890 / 4,000 / 5,100
	Heating -7°C	Rated	W	2,600	3,000
Power Input	Cooling	Rated	W	656	1,080
	Heating	Rated	W	800	1,050
EER			W / W	3.81	3.24
S.E.E.R.				7.0	6.6
P design C			kW	2.5	3.5
COP			W / W	4.13	3.81
S.C.O.P. (Average / Warmer)				4.0 / 4.9	4.0 / 4.9
P design H (Average / Warmer)			kW	2.5 / 1.3	2.5 / 1.3
Energy Label (A+++ to D Scale)	Cooling			A++	A++
	Heating (Average / Warmer)			A+ / A++	A+ / A++
Annual Energy Consumption	Cooling		kWh	125	186
	Heating (Average / Warmer)		kWh	875 / 371	875 / 371
Sound Pressure	Cooling	S / L / M / H	dB(A)	19 / 27 / 35 / 41	19 / 27 / 35 / 41
	Heating	L / M / H	dB(A)	27 / 35 / 41	27 / 35 / 41
Sound Power	Cooling	Power	dB(A)	59	59
	Heating	S / L / M / H	m³ / min	3.0 / 4.2 / 7.5 / 10.0	3.0 / 4.2 / 7.5 / 10.0
Air Flow Rate	Cooling	Max (Power)	m³ / min	12.5	12.5
	Heating	L / M / H	m³ / min	5.6 / 7.2 / 10.0	5.6 / 7.2 / 10.0
Dehumidification Rate			l/h	1.1	1.3
		Rated	A	3.3	4.7
Running Current	Cooling	Max	A	6.0	6.0
	Heating	Rated	A	4.0	4.7
		Max	A	7.0	7.0
Starting Current	Cooling / Heating	Rated	A	3.3 / 4.0	4.7 / 4.7
Power Supply			Ø V, Hz	1, 220-240, 50	1, 220-240, 50
Circuit Breaker			A	15	15
Power Supply Cable			N x mm²	3 x 1.0	3 x 1.0
Power & Transmission Cable			N x mm²	4 x 1.0	4 x 1.0
Dimension			mm	837 x 308 x 189	837 x 308 x 189
Net Weight			kg	9.1	9.1
Fan Motor Output			W	30	30
OUTDOOR				DC09RT UA3	DC12RT UA3
Operation Range	Cooling	Min / Max	°CDB	-10 / 48	-10 / 48
	Heating	Min / Max	°CDB	-10 / 24	-10 / 24
Sound Pressure	Cooling	High	dB(A)	48	48
	Heating	High	dB(A)	50	50
Sound Power	Cooling	High	dB(A)	65	65
	Heating	High	dB(A)	65	65
Air Flow Rate	Cooling	High	m³ / min	27	27
	Heating	High	m³ / min	27	27
Piping	Length (Odu / ldu)	Min / Max	m	3 / 15	3 / 15
	Elevation (Odu / ldu)	Max	m	7	7
Piping Connection	Liquid	OD (Outside)	mm (inch)	6.35 (1/4)	6.35 (1/4)
	Gas	OD (Outside)	mm (inch)	9.52 (3/8)	9.52 (3/8)
Drain Hose Size		OD (Outside)	mm (inch)	27 / 32	27 / 32
	Type			R32	R32
Refrigerant	Charge at 7.5m		kg	0.700	0.700
	Additional charge		t-CO ₂ eq	0.473	0.473
	GWP		g/m	20	20
Fan Motor Output			W	675	675
Compressor Type				43	43
Net Weight			kg	25.1	25.1
Dimension			mm	717 x 495 x 230	717 x 495 x 230

※ This product contains Fluorinated greenhouse gases (R32).
 ※ S : Sleep / L : Low / M : Medium / H : High
 ※ GWP : Global warming potential
 ※ t-CO₂eq : F-gas(kg)*GWP/1000
 ※ Specification, design and feature are subject to change without prior notice.

STANDARD PLUS



LG participates in the ECP programme for EUROVENT AC program. Check ongoing validity of certification: www.eurovent-certification.com

Embedded Wi-Fi

Smart Diagnosis

Active Energy Control

Energy Display

Auto Cleaning

Jet Cool

4 Way Swing

Fast Heating

Gold Fin™

Comfort Air

Low Noise 19dB (9k, 12k)

Silent Mode

Quick & Easy Installation

• Single Combination

UNIT				9K	12K	18K	24K
INDOOR				PC09SQ NSJ	PC12SQ NSJ	PC18SQ NSK	PC24SQ NSK
Capacity	Cooling	Min / Rated / Max	W	890 / 2,500 / 3,700	890 / 3,500 / 4,040	900 / 5,000 / 5,500	900 / 6,600 / 7,420
	Heating	Min / Rated / Max	W	890 / 3,300 / 4,100	890 / 4,000 / 5,100	900 / 5,800 / 6,400	900 / 7,500 / 8,640
	Heating -7°C	Rated	W	2,600	3,000	4,200	6,000
Power Input	Cooling	Rated	W	656	1,080	1,562	2,164
	Heating	Rated	W	800	1,050	1,611	2,238
EER			W / W	3.81	3.24	3.20	3.05
S.E.E.R.				7.0	6.6	7.0	6.9
P design C			kW	2.5	3.5	5.0	6.6
COP			W / W	4.13	3.81	3.60	3.35
S.C.O.P. (Average / Warmer)				4.0 / 4.9	4.0 / 4.9	4.3 / 5.3	4.3 / 5.3
P design H (Average / Warmer)			kW	2.5 / 1.3	2.5 / 1.3	3.9 / 2.1	5.0 / 2.7
Energy Label (A+++ to D Scale)	Cooling			A++	A++	A++	A++
	Heating (Average / Warmer)			A+ / A++	A+ / A++	A+ / A+++	A+ / A+++
Annual Energy Consumption	Cooling		kWh	125	186	250	335
	Heating (Average / Warmer)		kWh	875 / 371	875 / 371	1,270 / 555	1,628 / 713
Sound Pressure	Cooling	S / L / M / H	dB(A)	19 / 27 / 35 / 41	19 / 27 / 35 / 41	31 / 34 / 39 / 44	31 / 34 / 42 / 47
	Heating	L / M / H	dB(A)	27 / 35 / 41	27 / 35 / 41	34 / 39 / 44	34 / 42 / 47
Sound Power	Cooling		dB(A)	59	59	60	65
	Heating		dB(A)	59	59	60	65
Air Flow Rate	Cooling	S / L / M / H	m³ / min	3.0 / 4.2 / 7.5 / 10.0	3.0 / 4.2 / 7.5 / 10.0	8.0 / 10.5 / 13.0 / 14.5	8.0 / 10.5 / 13.1 / 16.1
	Heating	Max (Power)	m³ / min	12.5	12.5	15.5	20.0
Dehumidification Rate	Cooling		m³ / min	5.6 / 7.2 / 10.0	5.6 / 7.2 / 10.0	11.0 / 13.5 / 16.0	10.5 / 13.1 / 16.1
	Heating		l/h	1.1	1.3	1.8	2.5
Running Current	Cooling	Rated	A	3.3	4.7	6.9	9.8
		Max	A	6.0	6.0	9.0	14.0
	Heating	Rated	A	4.0	4.7	7.1	10.4
Starting Current	Max	A	7.0	7.0	9.5	14.0	
Power Supply	Cooling / Heating	Rated	A	3.3 / 4.0	4.7 / 4.7	6.9 / 7.1	9.8 / 10.4
Circuit Breaker			Ø V, Hz	1, 220-240, 50	1, 220-240, 50	1, 220-240, 50	1, 220-240, 50
Power Supply Cable			A	15	15	20	25
Power & Transmission Cable			N x mm²	3 x 1.0	3 x 1.0	3 x 1.5	3 x 2.5
Dimension			N x mm²	4 x 1.0 (Including Earth)	4 x 1.0 (Including Earth)	4 x 1.0 (Including Earth)	4 x 1.0 (Including Earth)
Net Weight			mm	837 x 308 x 189	837 x 308 x 189	998 x 345 x 210	998 x 345 x 210
Fan Motor Output			kg	8.7	8.7	11.9	12.7
			W	30	30	30	60
OUTDOOR				PC09SQ UA3	PC12SQ UA3	PC18SQ UL2	PC24SQ U24
Operation Range	Cooling	Min / Max	°CDB	-10 / 48	-10 / 48	-15 / 48	-15 / 48
	Heating	Min / Max	°CDB	-10 / 24	-10 / 24	-10 / 24	-10 / 24
Sound Pressure	Cooling	High	dB(A)	48	48	53	54
	Heating	High	dB(A)	50	50	55	57
Sound Power	Cooling	High	dB(A)	65	65	65	70
	Heating	High	dB(A)	27	27	35	50
Air Flow Rate	Cooling	High	m³ / min	27	27	35	50
	Heating	High	m³ / min	27	27	35	50
Piping	Length (Odu / Idu)	Min / Max	m	3 / 15	3 / 15	3 / 20	3 / 30
	Elevation (Odu / Idu)	Max	m	7	7	10	15
Piping Connection	Liquid	OD (Outside)	mm (inch)	6.35 (1/4)	6.35 (1/4)	6.35 (1/4)	6.35 (1/4)
	Gas	OD (Outside)	mm (inch)	9.52 (3/8)	9.52 (3/8)	12.7 (1/2)	15.88 (5/8)
Drain Hose Size			mm (inch)	21.5 (0.85)	21.5 (0.85)	21.5 (0.85)	21.5 (0.85)
Refrigerant	Type			R32	R32	R32	R32
	Charge at 7.5m		kg	0.700	0.700	1.000	1.100
	t-CO ₂ eq		kg	0.473	0.473	0.675	0.743
	Additional charge		g/m	20	20	20	20
Fan Motor Output			W	43	43	43	85
Compressor Type				Twin Rotary	Twin Rotary	Twin Rotary	Twin Rotary
Net Weight			kg	25.1	25.1	34.4	46.0
Dimension			mm	717 x 495 x 230	717 x 495 x 230	770 x 545 x 288	870 x 650 x 330

※ This product contains Fluorinated greenhouse gases (R32).
 ※ S : Sleep / L : Low / M : Medium / H : High
 ※ GWP : Global warming potential
 ※ t-CO₂eq : F-gas(kg)*GWP/1000
 ※ Specification, design and feature are subject to change without prior notice.

STANDARD 2



LG participates in the ECP programme for EUROVENT AC program. Check ongoing validity of certification: www.eurovent-certification.com

Embedded Wi-Fi

Smart Diagnosis

Active Energy Control

Energy Display

Auto Cleaning

Jet Cool

4 Way Swing

Fast Heating

Gold Fin™

Comfort Air

Low Noise 19dB (9k, 12k)

Silent Mode

Quick & Easy Installation

• Single Combination

UNIT				9K	12K	18K	24K
INDOOR				S09ET NSJ	S12ET NSJ	S18ET NSK	S24ET NSK
Capacity	Cooling	Min / Rated / Max	W	890 / 2,500 / 3,700	890 / 3,500 / 4,040	900 / 5,000 / 5,500	900 / 6,600 / 7,420
	Heating	Min / Rated / Max	W	890 / 3,300 / 4,100	890 / 4,000 / 5,100	900 / 5,800 / 6,400	900 / 7,500 / 8,640
	Heating -7°C	Rated	W	2,600	3,000	4,200	6,000
Power Input	Cooling	Rated	W	656	1,080	1,562	2,164
	Heating	Rated	W	800	1,050	1,611	2,238
EER			W / W	3.81	3.24	3.20	3.05
S.E.E.R.				7.0	6.6	7.0	6.9
P design C			kW	2.5	3.5	5.0	6.6
COP			W / W	4.13	3.81	3.60	3.35
S.C.O.P. (Average / Warmer)				4.0 / 4.9	4.0 / 4.9	4.3 / 5.3	4.3 / 5.3
P design H (Average / Warmer)			kW	2.5 / 1.3	2.5 / 1.3	3.9 / 2.1	5.0 / 2.7
Energy Label (A+++ to D Scale)	Cooling			A++	A++	A++	A++
	Heating (Average / Warmer)			A+ / A++	A+ / A++	A+ / A+++	A+ / A+++
Annual Energy Consumption	Cooling		kWh	125	186	250	335
	Heating (Average / Warmer)		kWh	875 / 371	875 / 371	1,270 / 555	1,628 / 713
Sound Pressure	Cooling	S / L / M / H	dB(A)	19 / 27 / 35 / 41	19 / 27 / 35 / 41	31 / 34 / 39 / 44	31 / 34 / 42 / 47
	Heating	L / M / H	dB(A)	27 / 35 / 41	27 / 35 / 41	34 / 39 / 44	34 / 42 / 47
Sound Power	Cooling		dB(A)	59	59	60	65
	Heating		dB(A)	59	59	60	65
Air Flow Rate	Cooling	S / L / M / H	m³ / min	3.0 / 4.2 / 7.5 / 10.0	3.0 / 4.2 / 7.5 / 10.0	8.0 / 10.5 / 13.0 / 14.5	8.0 / 10.5 / 13.1 / 16.1
	Heating	Max (Power)	m³ / min	12.5	12.5	15.5	20.0
Dehumidification Rate	Cooling		m³ / min	5.6 / 7.2 / 10.0	5.6 / 7.2 / 10.0	11.0 / 13.5 / 16.0	10.5 / 13.1 / 16.1
	Heating		l/h	1.1	1.3	1.8	2.5
Running Current	Cooling	Rated	A	3.3	4.7	6.9	9.8
		Max	A	6.0	6.0	9.0	14.0
	Heating	Rated	A	4.0	4.7	7.1	10.4
Starting Current	Max	A	7.0	7.0	9.5	14.0	
Power Supply	Cooling / Heating	Rated	A	3.3 / 4.0	4.7 / 4.7	6.9 / 7.1	9.8 / 10.4
Circuit Breaker			Ø V, Hz	1, 220-240, 50	1, 220-240, 50	1, 220-240, 50	1, 220-240, 50
Power Supply Cable			A	15	15	20	25
Power & Transmission Cable			N x mm²	3 x 1.0	3 x 1.0	3 x 1.5	3 x 2.5
Dimension			N x mm²	4 x 1.0	4 x 1.0	4 x 1.0	4 x 1.0
Net Weight			mm	837 x 308 x 189	837 x 308 x 189	998 x 345 x 210	998 x 345 x 210
Fan Motor Output			kg	8.7	8.7	11.9	12.7
			W	30	30	30	58
OUTDOOR				S09ET UA3	S12ET UA3	S18ET UL2	S24ET U24
Operation Range	Cooling	Min / Max	°CDB	-10 / 48	-10 / 48	-15 / 48	-15 / 48
	Heating	Min / Max	°CDB	-10 / 24	-10 / 24	-10 / 24	-10 / 24
Sound Pressure	Cooling	High	dB(A)	48	48	53	54
	Heating	High	dB(A)	50	50	55	57
Sound Power	Cooling	High	dB(A)	65	65	65	70
	Heating	High	dB(A)	27	27	35	49
Air Flow Rate	Cooling	High	m³ / min	27	27	35	49
	Heating	High	m³ / min	27	27	35	49
Piping	Length (Odu / Idu)	Min / Max	m	3 / 15	3 / 15	3 / 20	3 / 30
	Elevation (Odu / Idu)	Max	m	7	7	10	15
Piping Connection	Liquid	OD (Outside)	mm (inch)	6.35 (1/4)	6.35 (1/4)	6.35 (1/4)	6.35 (1/4)
	Gas	OD (Outside)	mm (inch)	9.52 (3/8)	9.52 (3/8)	12.7 (1/2)	15.88 (5/8)
Drain Hose Size			mm (inch)	27 / 32	27 / 32	27 / 32	27 / 32
Refrigerant	Type			R32	R32	R32	R32
	Charge at 7.5m		kg	0.700	0.700	1.000	1.100
	t-CO ₂ eq		kg	0.473	0.473	0.675	0.743
	Additional charge		g/m	20	20	20	20
Fan Motor Output			W	43	43	43	85
Compressor Type				Twin Rotary	Twin Rotary	Twin Rotary	Twin Rotary
Net Weight			kg	25.1	25.1	34.4	46.0
Dimension			mm	717 x 495 x 230	717 x 495 x 230	770 x 545 x 288	870 x 650 x 330

※ This product contains Fluorinated greenhouse gases (R32).
 ※ S : Sleep / L : Low / M : Medium / H : High
 ※ GWP : Global warming potential
 ※ t-CO₂eq : F-gas(kg)*GWP/1000
 ※ Specification, design and feature are subject to change without prior notice.

STANDARD



LG participates in the ECP programme for EUROVENT AC program. Check ongoing validity of certification: www.eurovent-certification.com

- Smart Diagnosis
- Active Energy Control
- Energy Display
- Auto Cleaning
- Jet Cool
- 2 Way Swing (9k, 12k)
- 4 Way Swing (18k, 24k)
- Fast Heating
- Gold Fin™
- Comfort Air
- Low Noise 19dB (9k, 12k)
- Silent Mode
- Quick & Easy Installation

• Single Combination

UNIT				9K	12K	18K	24K
INDOOR				S09EQ NSJ	S12EQ NSJ	S18EQ NSK	S24EQ NSK
Capacity	Cooling	Min / Rated / Max	W	890 / 2,500 / 3,700	890 / 3,500 / 4,040	900 / 5,000 / 5,500	900 / 6,600 / 7,420
	Heating	Min / Rated / Max	W	890 / 3,300 / 4,100	890 / 4,000 / 5,100	900 / 5,800 / 6,400	900 / 7,500 / 8,640
	Heating -7°C	Rated	W	2,600	3,000	4,200	6,000
Power Input	Cooling	Rated	W	656	1,080	1,562	2,164
	Heating	Rated	W	800	1,050	1,611	2,238
EER			W / W	3.81	3.24	3.20	3.05
S.E.E.R.				7.0	6.6	7.0	6.9
P design C			kW	2.5	3.5	5.0	6.6
COP			W / W	4.13	3.81	3.60	3.35
S.C.O.P. (Average / Warmer)				4.0 / 4.9	4.0 / 4.9	4.3 / 5.3	4.3 / 5.3
P design H (Average / Warmer)			kW	2.5 / 1.3	2.5 / 1.3	3.9 / 2.1	5.0 / 2.7
Energy Label (A+++ to D Scale)	Cooling			A++	A++	A++	A++
	Heating (Average / Warmer)			A+ / A++	A+ / A++	A+ / A+++	A+ / A+++
Annual Energy Consumption	Cooling		kWh	125	186	250	335
	Heating (Average / Warmer)		kWh	875 / 371	875 / 371	1,270 / 555	1,628 / 713
Sound Pressure	Cooling	S / L / M / H	dB(A)	19 / 27 / 35 / 41	19 / 27 / 35 / 41	31 / 34 / 39 / 44	31 / 34 / 42 / 47
	Heating	L / M / H	dB(A)	27 / 35 / 41	27 / 35 / 41	34 / 39 / 44	34 / 42 / 47
Sound Power	Cooling	Power	dB(A)	59	59	60	65
	Heating	S / L / M / H	m³ / min	3.0 / 4.2 / 7.5 / 10.0	3.0 / 4.2 / 7.5 / 10.0	8.0 / 10.5 / 13.0 / 14.5	8.0 / 10.5 / 13.1 / 16.1
Air Flow Rate	Cooling	Max (Power)	m³ / min	12.5	12.5	15.5	20.0
	Heating	L / M / H	m³ / min	5.6 / 7.2 / 10.0	5.6 / 7.2 / 10.0	11.0 / 13.5 / 16.0	10.5 / 13.1 / 16.1
Dehumidification Rate	Cooling		l/h	1.1	1.3	1.8	2.5
	Heating	Rated	A	3.3	4.7	6.9	9.8
Running Current	Cooling	Max	A	6.0	6.0	9.0	14.0
		Rated	A	4.0	4.7	7.1	10.4
	Heating	Max	A	7.0	7.0	9.5	14.0
Starting Current	Cooling / Heating	Rated	A	3.3 / 4.0	4.7 / 4.7	6.9 / 7.1	9.8 / 10.4
Power Supply			Ø, V, Hz	1, 220-240, 50	1, 220-240, 50	1, 220-240, 50	1, 220-240, 50
Circuit Breaker			A	15	15	20	25
Power Supply Cable			N x mm²	3 x 1.0	3 x 1.0	3 x 1.5	3 x 2.5
Power & Transmission Cable			N x mm²	4 x 1.0 (Including Earth)	4 x 1.0 (Including Earth)	4 x 1.0 (Including Earth)	4 x 1.0 (Including Earth)
Dimension			mm	837 x 308 x 189	837 x 308 x 189	998 x 345 x 210	998 x 345 x 210
Net Weight			kg	8.7	8.7	11.9	12.7
Fan Motor Output			W	30	30	30	60
OUTDOOR				S09EQ UA3	S12EQ UA3	S18EQ UL2	S24EQ U24
Operation Range	Cooling	Min/Max	°CDB	-10 / 48	-10 / 48	-15 / 48	-15 / 48
	Heating	Min/Max	°CDB	-10 / 24	-10 / 24	-10 / 24	-10 / 24
Sound Pressure	Cooling	High	dB(A)	48	48	53	54
	Heating	High	dB(A)	50	50	55	57
Sound Power	Cooling	High	dB(A)	65	65	65	70
	Heating	High	dB(A)	27	27	35	50
Air Flow Rate	Length (Odu / ldu)	Min / Max	m	3 / 15	3 / 15	3 / 20	3 / 30
	Elevation (Odu / ldu)	Max	m	7	7	10	15
Piping Connection	Liquid	OD (Outside)	mm (inch)	6.35 (1/4)	6.35 (1/4)	6.35 (1/4)	6.35 (1/4)
	Gas	OD (Outside)	mm (inch)	9.52 (3/8)	9.52 (3/8)	12.7 (1/2)	15.88 (5/8)
Drain Hose Size		OD (Outside)	mm (inch)	21.5 (0.85)	21.5 (0.85)	21.5 (0.85)	21.5 (0.85)
Refrigerant	Type			R32	R32	R32	R32
		Charge at 7.5m	kg	0.700	0.700	1.000	1.100
	t-CO ₂ eq		0.473	0.473	0.675	0.743	
	Additional charge	g/m	20	20	20	20	
Fan Motor Output			W	43	43	43	85
	Compressor Type			Twin Rotary	Twin Rotary	Twin Rotary	Twin Rotary
Net Weight			kg	25.1	25.1	34.4	46.0
Dimension			mm	717 x 495 x 230	717 x 495 x 230	770 x 545 x 288	870 x 650 x 330

※ This product contains Fluorinated greenhouse gases (R32).
 ※ S : Sleep / L : Low / M : Medium / H : High
 ※ GWP : Global warming potential
 ※ t-CO₂eq : F-gas(kg)*GWP/1000
 ※ Specification, design and feature are subject to change without prior notice.

STANDARD 3



NEW



LG participates in the ECP programme for EUROVENT AC program. Check ongoing validity of certification: www.eurovent-certification.com

- Smart Diagnosis
- Active Energy Control
- Energy Display
- Auto Cleaning
- Jet Cool
- 2 Way Swing (9k, 12k)
- Fast Heating
- Gold Fin™
- Comfort Air
- Low Noise 19dB (9k, 12k)
- Silent Mode
- Quick & Easy Installation

• Single Combination

UNIT				9K	12K	
INDOOR				S09ES NSA	S12ES NSJ	S12EW NSJ
Capacity	Cooling	Min / Rated / Max	W	890/2,500/3,400	890 / 3,500 / 4,040	890 / 3,500 / 4,040
	Heating	Min / Rated / Max	W	890/3,200/3,700	890 / 4,000 / 5,100	890 / 4,000 / 5,100
	Heating -7°C	Rated	W	2,700	3,600	3,600
Power Input	Cooling	Rated	W	715	1,080	1,080
	Heating	Rated	W	860	1,050	1,050
EER			W / W	3.50	3.24	3.24
S.E.E.R.				6.5	6.6	6.6
P design C			kW	2.5	3.5	3.5
COP			W / W	3.72	3.81	3.81
S.C.O.P. (Average / Warmer)				3.8 / 4.2	4.0 / 4.9	4.0 / 4.9
P design H (Average / Warmer)			kW	2.3 / 1.2	2.5 / 1.3	2.5 / 1.3
Energy Label (A+++ to D Scale)	Cooling			A++	A++	A++
	Heating (Average / Warmer)			A / A+	A+ / A++	A+ / A++
Annual Energy Consumption	Cooling		kWh	135	186	186
	Heating (Average / Warmer)		kWh	847 / 400	875 / 386	875 / 371
Sound Pressure	Cooling	S / L / M / H	dB(A)	22 / 28 / 36 / 42	19 / 27 / 35 / 41	19 / 27 / 35 / 41
	Heating	L / M / H	dB(A)	28 / 36 / 42	27 / 35 / 41	27 / 35 / 41
Sound Power	Cooling	Power	dB(A)	60	59	59
	Heating	S / L / M / H	m³ / min	2.0 / 3.0 / 6.0 / 8.0	3.0 / 4.2 / 7.5 / 10.0	3.0 / 4.2 / 7.5 / 10.0
Air Flow Rate	Cooling	Max (Power)	m³ / min	10.2	12.5	12.5
	Heating	L / M / H	m³ / min	4.5 / 6.0 / 8.0	5.6 / 7.2 / 10.0	5.6 / 7.2 / 10.0
Dehumidification Rate	Cooling		l/h	1.1	1.3	1.3
	Heating	Rated	A	3.3	4.7	4.7
Running Current	Cooling	Max	A	6.0	6.0	6.0
		Rated	A	4.0	4.7	4.7
	Heating	Max	A	7.0	7.0	7.0
Starting Current	Cooling / Heating	Rated	A	3.3 / 4.0	4.7 / 4.7	4.7 / 4.7
Power Supply			Ø, V, Hz	1, 220-240, 50	1, 220-240, 50	1, 220-240, 50
Circuit Breaker			A	15	15	15
Power Supply Cable			N x mm²	3 x 1.0	3 x 1.0	3 x 1.0
Power & Transmission Cable			N x mm²	4 x 1.0	4 x 1.0	4 x 1.0
Dimension			mm	753 x 308 x 189	837 x 308 x 189	837 x 308 x 189
Net Weight			kg	8.0	8.5	8.7
Fan Motor Output			W	30	30	30
OUTDOOR				S09ES UA3	S12ES UA3	S12EW UA3
Operation Range	Cooling	Min/Max	°CDB	-10 / 48	-10 / 48	-10 / 48
	Heating	Min/Max	°CDB	-10 / 24	-10 / 24	-10 / 24
Sound Pressure	Cooling	High	dB(A)	48	48	48
	Heating	High	dB(A)	50	50	50
Sound Power	Cooling	High	dB(A)	65	65	65
	Heating	High	dB(A)	27	27	27
Air Flow Rate	Length (Odu / ldu)	Min / Max	m	3 / 15	3 / 15	3 / 15
	Elevation (Odu / ldu)	Max	m	7	7	7
Piping Connection	Liquid	OD (Outside)	mm (inch)	6.35 (1/4)	6.35 (1/4)	6.35 (1/4)
	Gas	OD (Outside)	mm (inch)	9.52 (3/8)	9.52 (3/8)	9.52 (3/8)
Drain Hose Size		OD (Outside)	mm (inch)	21.5 (0.85)	21.5 (0.85)	21.5 (0.85)
Refrigerant	Type			R32	R32	R32
		Charge at 7.5m	kg	0.670	0.700	0.700
	t-CO ₂ eq		0.452	0.473	0.473	
	Additional charge	g/m	20	20	20	
Fan Motor Output			W	30	43	43
	Compressor Type			Twin Rotary	Twin Rotary	Twin Rotary
Net Weight			kg	26	26	26
Dimension			mm	717 x 495 x 230	717 x 495 x 230	717 x 495 x 230

※ This product contains Fluorinated greenhouse gases (R32).
 ※ S : Sleep / L : Low / M : Medium / H : High
 ※ GWP : Global warming potential
 ※ t-CO₂eq : F-gas(kg)*GWP/1000
 ※ Specification, design and feature are subject to change without prior notice.

INDOOR UNITS

A09FT NSF / A12FT NSF

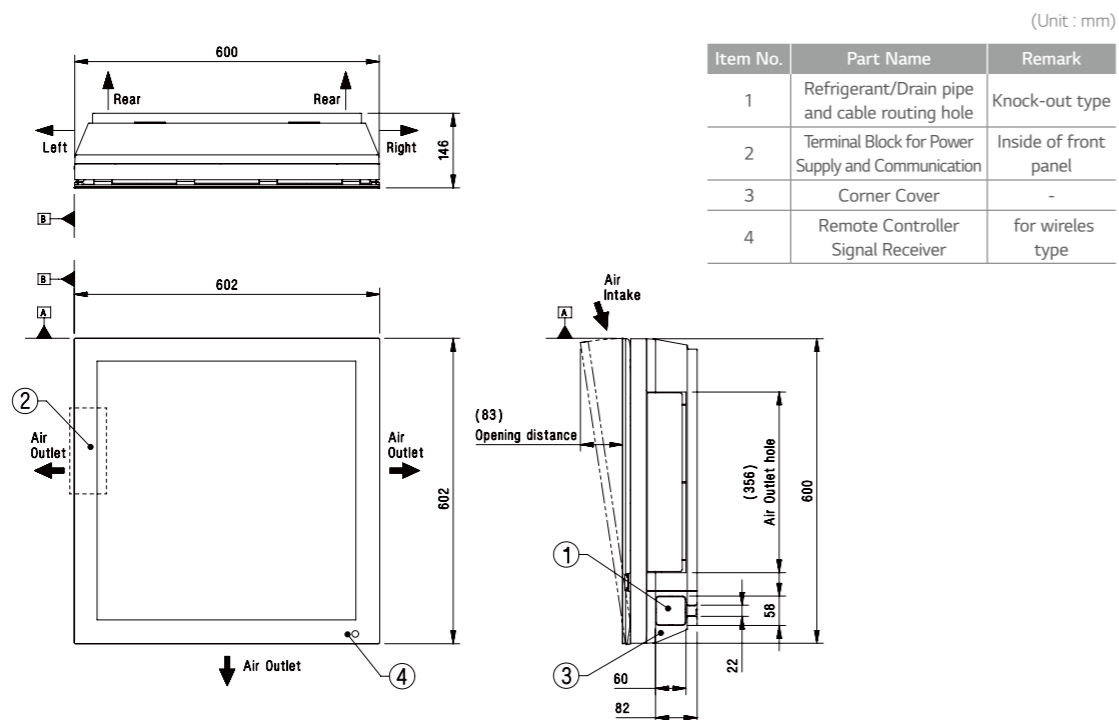

AC09BQ NSJ / AC12BQ NSJ / AC09SQ NSJ / AC12SQ NSJ

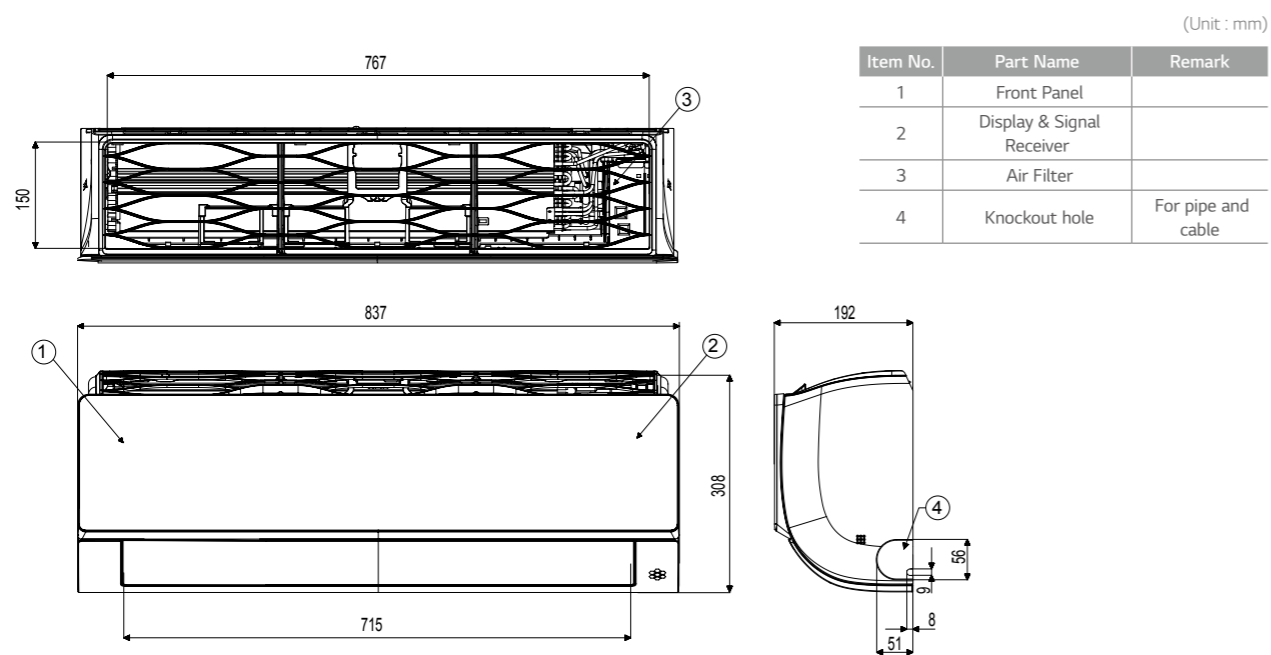

INDOOR UNITS

AC18BQ NSK / AC24BQ NSK / AC18SQ NSK

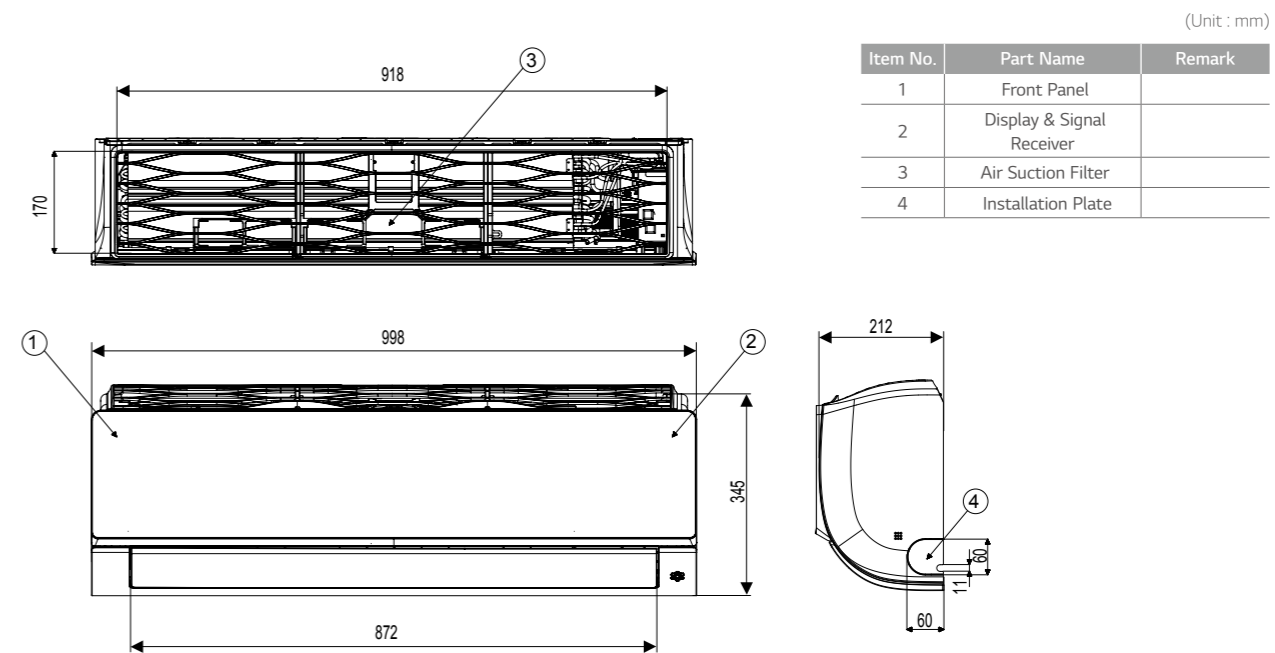

F09MT NSM / F12MT NSM

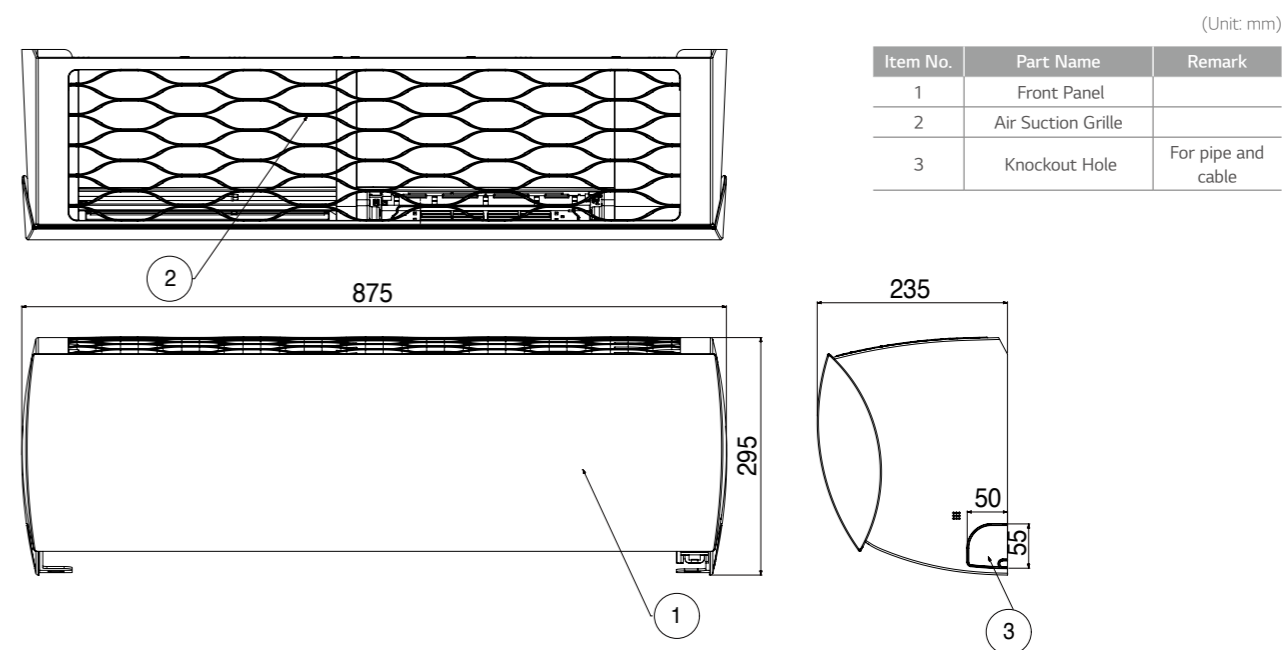

INDOOR UNITS

AP09RT NSJ / AP12RT NSJ

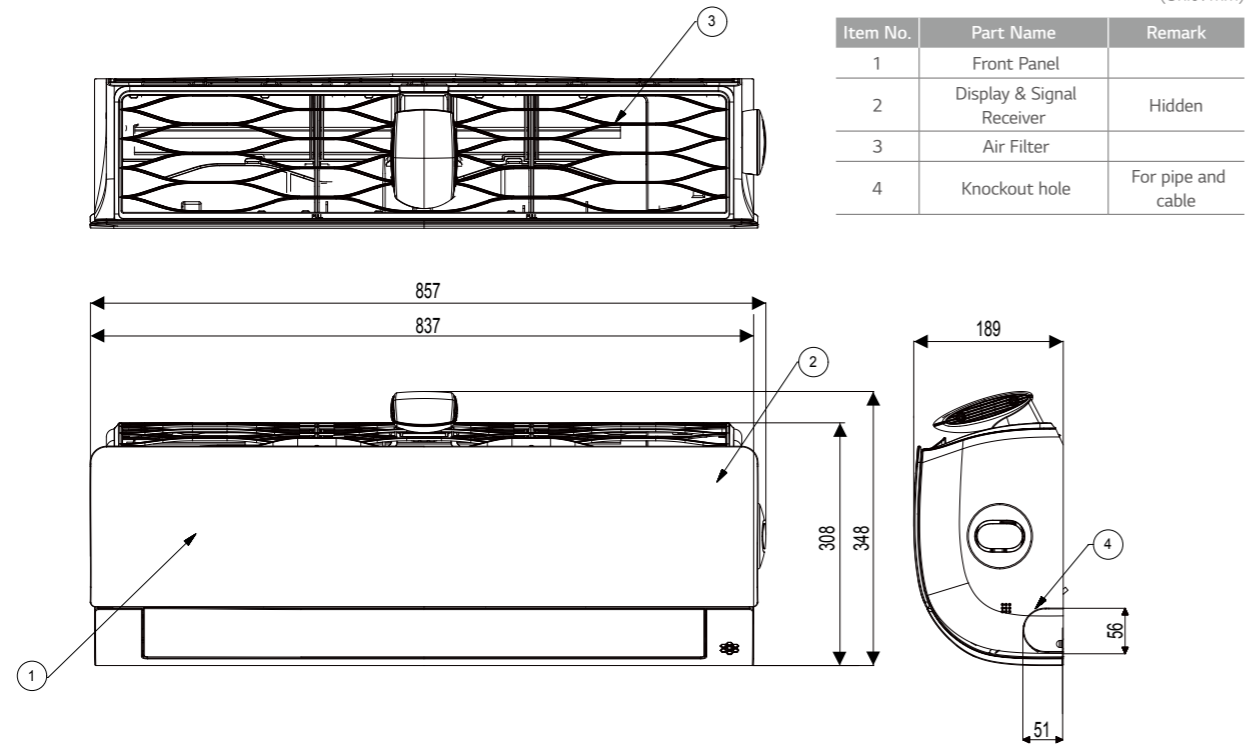

DC09RQ NSJ / DC12RQ NSJ / DC09RT NSJ / DC12RT NSJ / PC09SQ NSJ / PC12SQ NSJ / S09EQ NSJ / S12EQ NSJ / S09ET NSJ / S12ET NSJ / S12ES NSJ

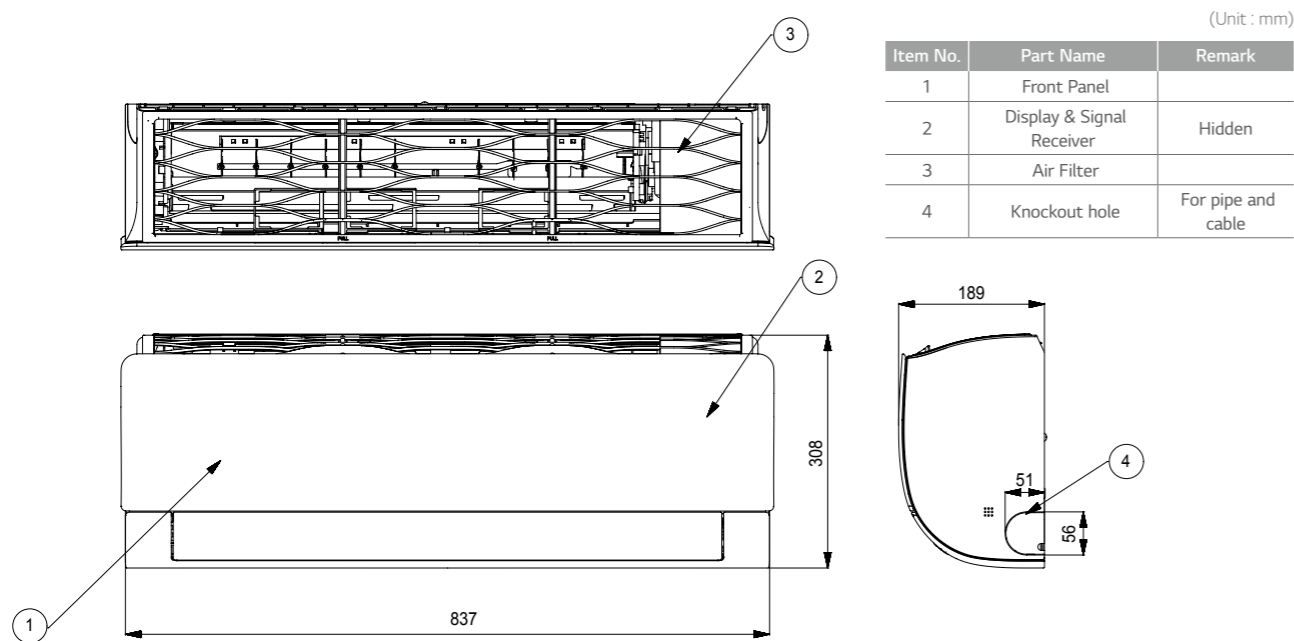

INDOOR UNITS

DC18RQ NSK / DC24RQ NSK / PC18SQ NSK / PC24SQ NSK / S18EQ NSK / S24EQ NSK / S18ET NSK / S24ET NSK

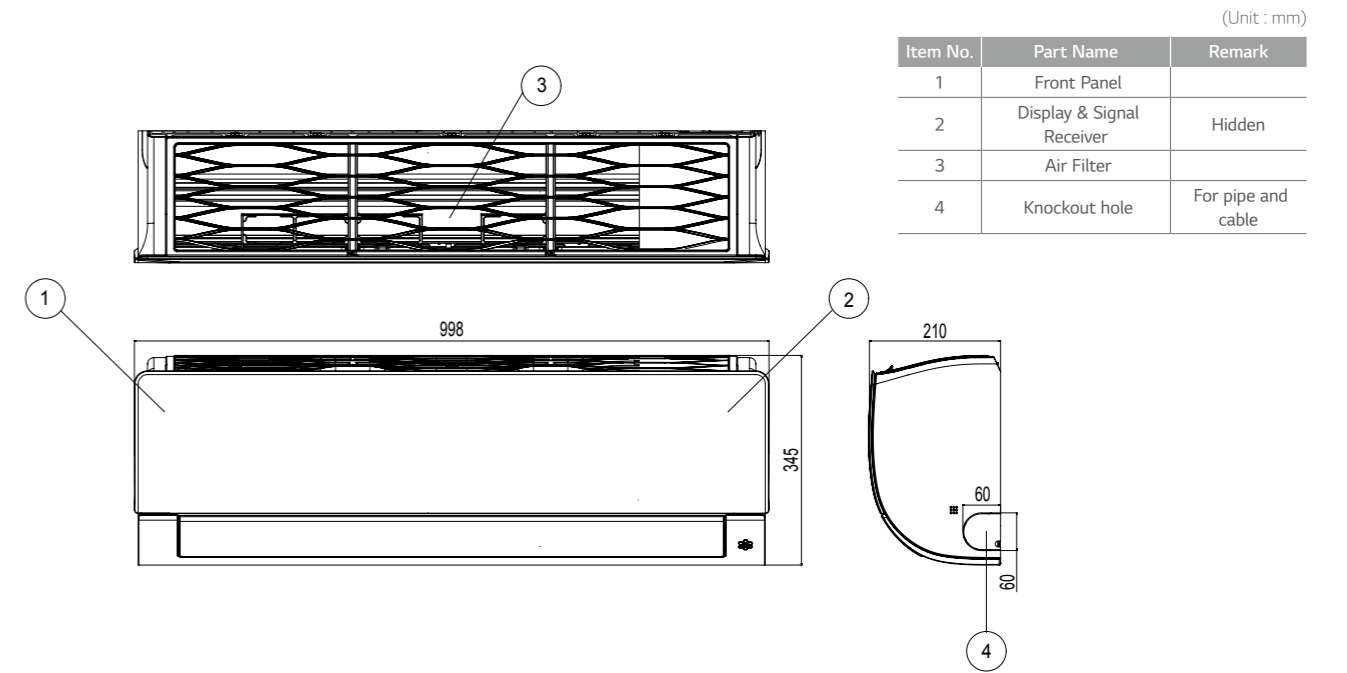

S09ES NSA

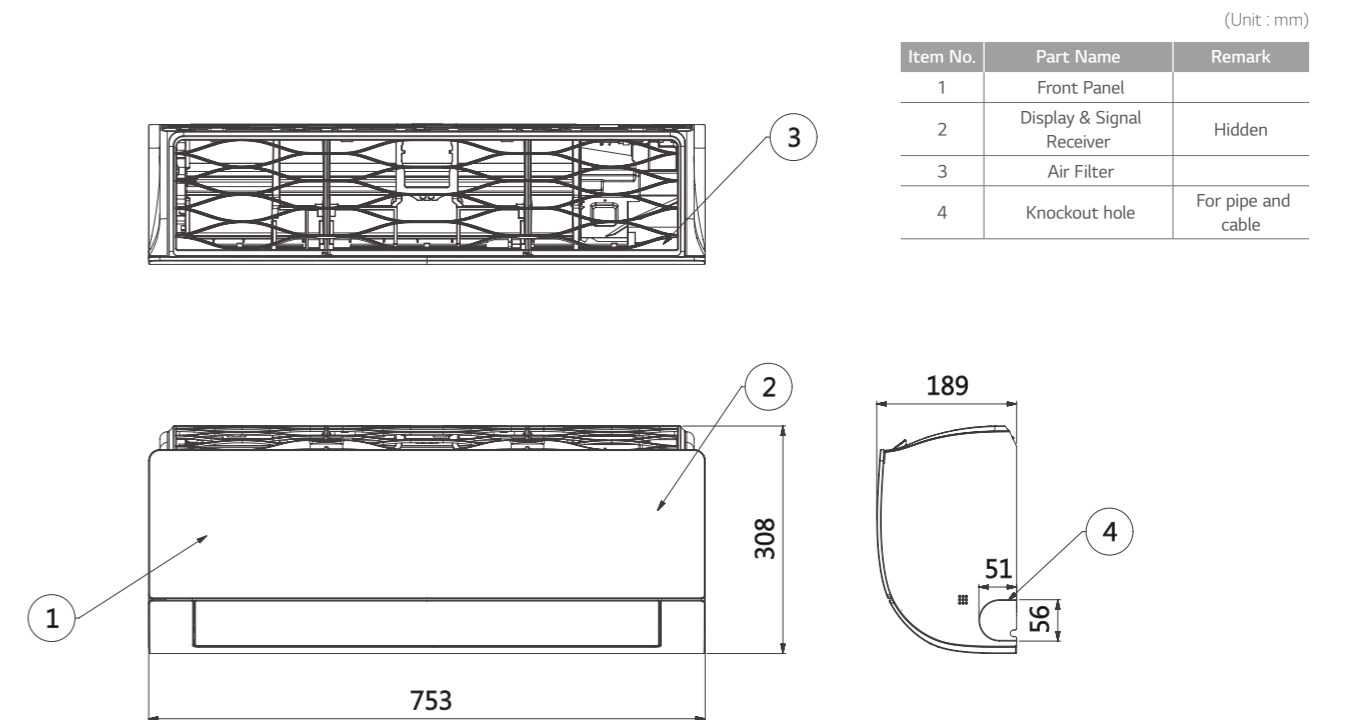

OUTDOOR UNITS

AC09BQ UA3 / AC12BQ UA3 / AC09SQ UA3 / AC12SQ UA3 / DC09RT UA3 / DC12RT UA3 / PC09SQ UA3 / PC12SQ UA3 / S09EQ UA3 / S12EQ UA3 / S09ET UA3 / S12ET UA3 / S12ES UA3 / AP09RT UA3 / AP12RT UA3 / S09ES UA3

(Unit: mm)



Item No.	Part Name
1	Air Outlet
2	Control Box
3	Power and Communication Cable Hole
4	Service Valve Cover
5	Gas Pipe Connection
6	Liquid Pipe Connection

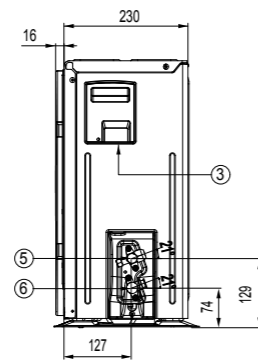
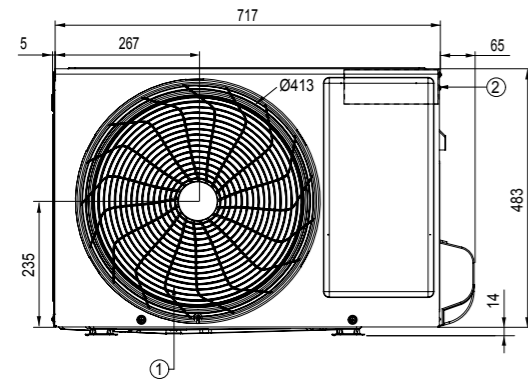

A09FT UL2 / A12FT UL2 / DC09RQ UL2 / DC12RQ UL2 / AC18BQ UL2 / AC18SQ UL2 / DC18RQ UL2 / PC18SQ UL2 / S18EQ UL2 / S18ET UL2

(Unit: mm)

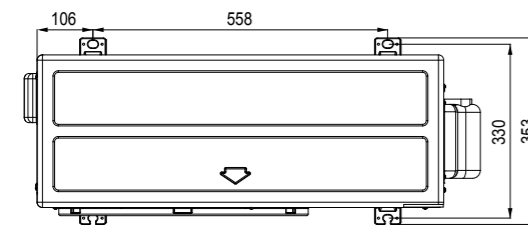

Item No.	Part Name
1	Air Outlet
2	Control Box
3	Power and Communication Cable Hole
4	Service Valve Cover
5	Gas Pipe Connection
6	Liquid Pipe Connection

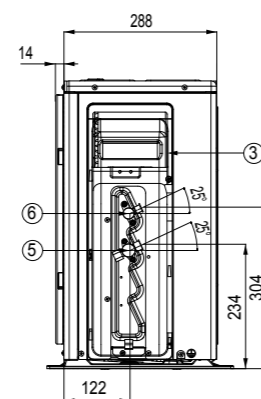
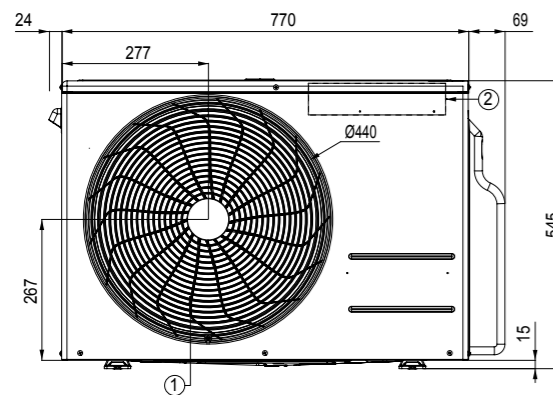

OUTDOOR UNITS

F09MT U24 / F12MT U24 / AC24BQ U24 / DC24RQ U24 / PC24SQ U24 / S24EQ U24 / S24ET U24

(Unit: mm)

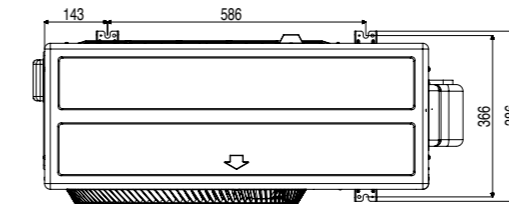

Item No.	Part Name
1	Air Outlet
2	Control Box
3	Power and Communication Cable Hole
4	Service Valve Cover
5	Gas Pipe Connection
6	Liquid Pipe Connection

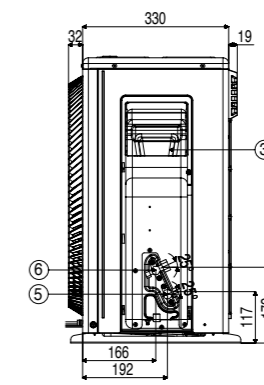
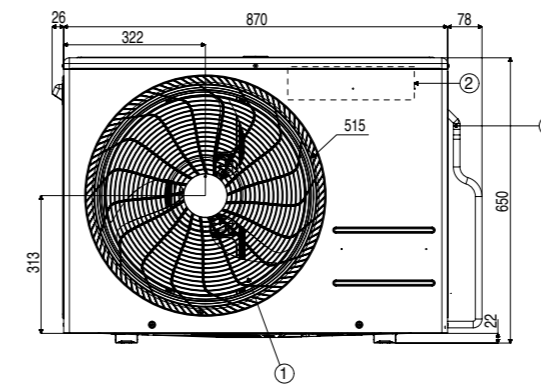

ACCESSORIES

	ARTCOOL GALLERY	ARTCOOL	PRESTIGE	DELUXE	DELUXE2	STANDARD PLUS	STANDARD2	STANDARD	STANDARD3
Wired Remote Controller	5k					Y			
	7k		Y		Y	Y		-	-
	9k	-	Y	Y	Y	Y	Y	-	-
	12k	-	Y	Y	Y	Y	Y	-	-
	15k					Y			
	18k		Y		Y	Y	Y	-	-
PI 485	5k					-			
	7k		-		Y*	-		-	-
	9k	Y	-	-	Y*	Y*	-	-	-
	12k	Y	-	-	Y*	Y*	-	-	-
	15k						-		
	18k		-		Y*		-	-	-
Dry Contact	5k					Y			
	7k		Y		Y	Y		-	-
	9k	Y	Y	Y	Y	Y	Y	-	-
	12k	Y	Y	Y	Y	Y	Y	-	-
	15k					Y			
	18k		Y		Y	Y	Y	-	-
24k		Y		Y	Y	Y	-	-	

* Y : Available
 * When connected to Multi 14k & 16k Outdoor units, this may not be supported.

Standard Wired Remote Control

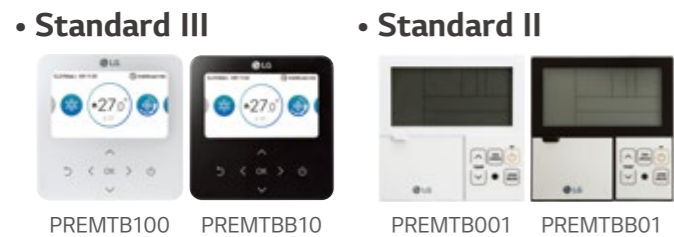

MODEL NAME	PREMTB100 PREMTBB10	PREMTB001 PREMTBB01
Operation Mode	On / Off, Fan Speed Control, Temperature Setting	
Mode Change	Cooling / Heating / Auto / Dehumidification / Fan	
Auto Swing / Vane Control	-	-
Reservation	Simple / Sleep / On, Off / Weekly / Holiday	
Time Display	-	-
Electrical Failure Compensation	-	-
Child Lock	-	-
Operation Status LED	-	-
Indoor Temperature Display	-	-
Wireless Remote Controller Receiver	-	-
Size (W x H x D, mm)	120 x 120 x 16	120 x 121 x 16
Backlight	-	-
Display AirQuality Status	-	-

※ Refer to each model PDB for applicable models.

PI 485



PMNFP14A1

Power : Single phase AC 220V 50/60Hz
 Max no of the indoor units that can be connected: 64 UNITS
 Model applied : RAC / Multi / Single / Therma V
 ※ Refer to each product PDB for applicable models

ACCESSORIES

Dry Contact



※ Refer to each product PDB for applicable models

MODEL	PDRYCB000	PDRYCB400	PDRYCB300	PDRYCB500
Contact Point	1 Control Point	2 Control Point	8 Control Point	Modbus RTU
Power Input	AC 220V from outside power source	DC 5V & 12V from indoor unit PCB	DC 5V & 12V from indoor unit PCB	DC 5V & 12V from indoor unit PDB
Voltage / Non Voltage Input	-	•	•	-
On / Off Control	•	•	•	•
Lock / Unlock	•	•	•	-
Fan Speed Setting	-	-	•	•
Thermo Off	-	•	•	-
Energy Saving	-	•	-	-
Temperature Setting	-	•	•	•
Error Monitoring	•	•	•	•
Operation Monitoring	•	•	•	•

Remote Control



Prestige
 Artcool
 Deluxe, Deluxe2,
 Standard Plus
 Standard, Standard2, Standard3

BUTTON	DISPLAY SCREEN	DESCRIPTION
	-	To turn on / off the air conditioner.
	88°	To adjust the desired room temperature in cooling, heating or auto changeover mode.
COMFORT AIR	-	To adjust the air flow to deflect wind.
LIGHT OFF	-	To set the brightness of the display on the indoor unit.
MODE		To select the cooling mode.
		To select the heating mode.
		To select the dehumidification mode.
		To select the fan mode.
FAN SPEED		To select the auto changeover / auto operation mode.
		To adjust the fan speed.
ENERGY CTRL.	-	To bring the effect of the power saving.
JET MODE		To change room temperature quickly.
ROOM TEMP		To adjust the air flow direction vertically or horizontally.
		To display the room temperature.
°C ↔ °F[5sec]		To change unit between °C and °F.
SET/CANCEL	-	To set / cancel the functions and timer.
	-	To adjust time.
	-	To turn on / off air conditioner automatically.
	-	To cancel the timer settings.