

Tetris W Rev

38÷615 kW

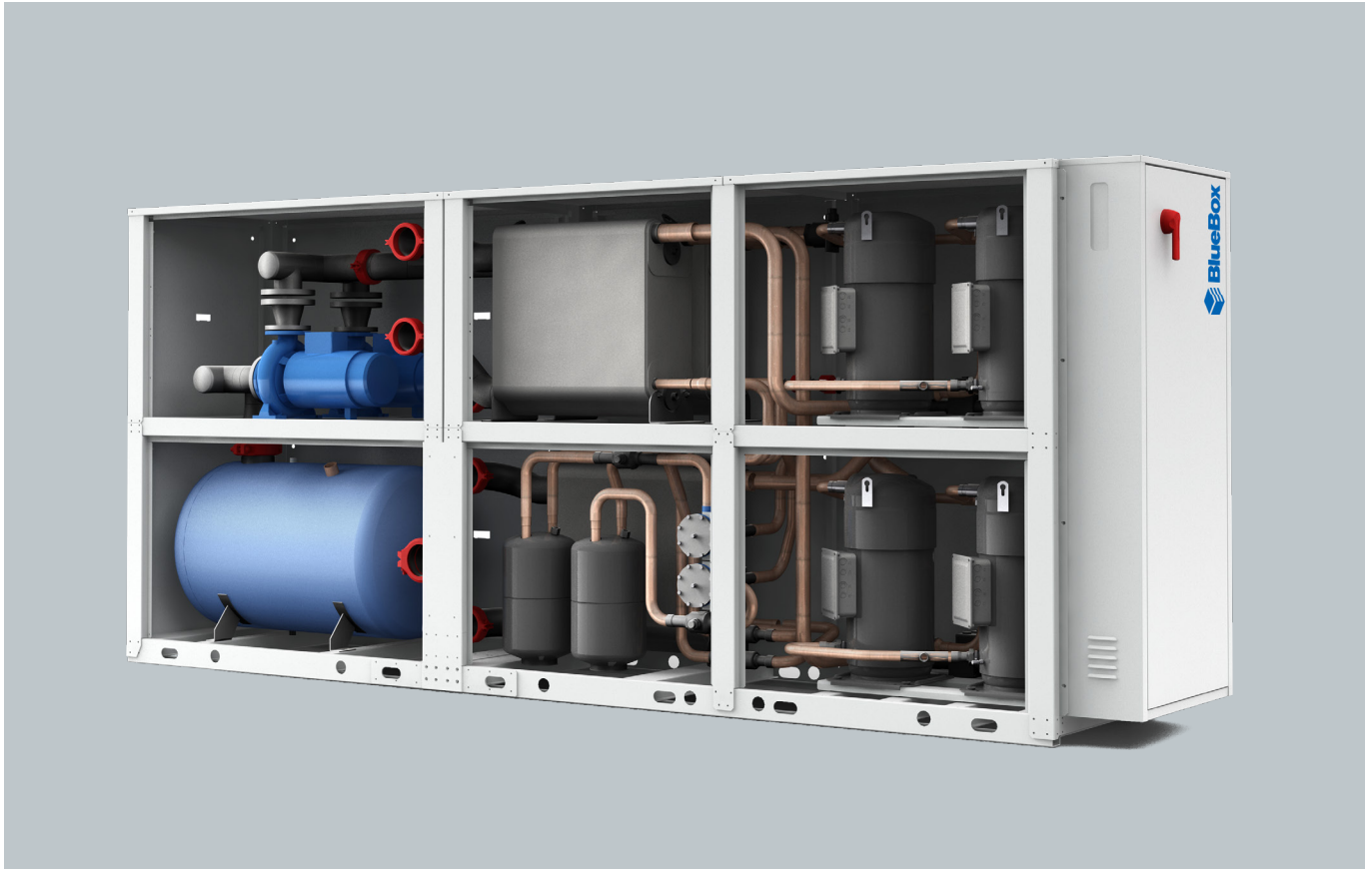

General

Chillers with heat pump versions for indoor installations. Extended range, versatile applications.

Configurations

OH: non-reversible heat pump

HPW: reversible heat pump on water side

HP: reversible heat pump on refrigerating side

/LN: low noise

/LC: with remote source-side heat exchanger

/DS: with desuperheater

/DC: with total recovery

Strengths

- ▶ Tier 2 compliance: sizes up to 400 kW
- ▶ The widest range of capacities and configurations on the market
- ▶ Easy handling: depth \leq 880 mm
- ▶ Integrated pumps for user, source and total heat recovery (option)
- ▶ Buffer tank (option)
- ▶ BlueThink advanced control with integrated web server. Multilogic function and Blueye[®] supervision system. (options)
- ▶ Flowzer: inverter driven pumps (options)



One machine, many solutions	3
Tetris W Rev	
Description of accessories	8
Refrigerant circuit accessories	8
Hydraulic circuit accessories	10
Electrical accessories	14
Other accessories	18
Technical specifications	19
Tetris W Rev	19
Tetris W Rev HP	23
Tetris W Rev OH	27
Tetris W Rev HPW	31
Tetris W Rev LC	35
Tetris W Rev LC/HP	39
Ecodesign	43
Electrical specifications	56
Pump data	72
Flow rate ranges of heat exchangers	73
Operating limits	76
Tetris W Rev - Tetris W Rev HP - Tetris W Rev OH - Tetris W Rev HPW	76
Tetris W Rev LC - Tetris W Rev LC/HP	77
Noise levels	78
Configurations that are not possible	80
Tables of dimensions	81
Installation advice	84
Water characteristics	84
Glycol mixtures	84
Minimum water content in the system	85
Installation site	85



ONE MACHINE, MANY SOLUTIONS

Tetris W Rev is the result of a platform developed with modular logic, which allows a highly flexible and configurable product to be obtained.

Since this is an indoor unit, the structure has been designed to be as compact as possible: its width of 875mm and height of 1,880mm allow even the largest model to pass easily through the doors of the technical rooms. Furthermore, the unit does not require manifolds for connection of the main heat exchangers and so also the installation space is further reduced.

Tetris W Rev offers a wide range of capacities and configurations: the range covers 31 models divided between single circuit units from 38 to 385kW and dual circuit units from 160 to 618kW. In the capacity range between 163 and 385kW, the customer can choose between the more compact single circuit units and the dual circuit units with higher ESEER values.

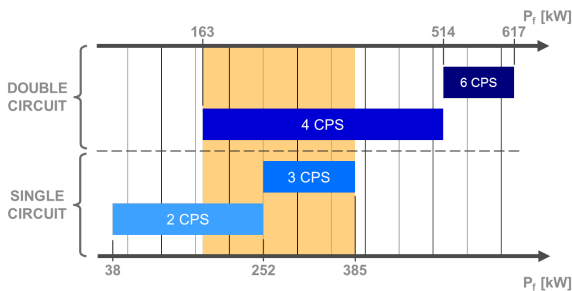

Extreme flexibility is also given for combination with different types of sources: evaporative tower, dry-cooler, well, geothermal probe or remote condenser, according to the most suitable and expedient convenient source. Depending on the choice and the type of application, the unit can be completed with the available accessories.

Built-in hydraulic modules



Tetris W Rev can be equipped with various set-ups of hydraulic modules, designed to have the flexibility required to cover all possible applications. One or two pumps (one as backup to the other) can be requested respectively for the user-side and source-side circuits and also (in the case of /DC version) the heat recovery-side circuit, up to a maximum of four pumps. Also, in combination with the user-side pumps, a buffer tank can be inserted inside the structure.

Each hydraulic module can be coupled with three different types of pump:

- standard, for available discharge heads of about 120kPa
- oversize, for available discharge heads of about 200kPa
- for fluids containing up to 50% glycol

The user-side hydraulic module can also be fitted with one of the Flowzer options, which allows you to make hydronic systems with constant flow rate, constant pressure or with variable flow rate user-side circuit, thanks to the use of inverter technology combined with advanced control. For further details, please refer to the description of Flowzer accessories in the "Hydraulic circuit accessories" chapter

The 4 forms of heat pump

Tetris W Rev offers four different heat pump set-ups to suit all types of application.

Tetris W Rev OH is a high efficiency non-reversible heat pump that is suitable for all applications in which the user needs only heating production. In this set-up, the unit is optimized to operate in heating mode only.

Tetris W Rev HPW is a high efficiency water-side reversible heat pump that is suitable for applications in which the user-side circuit and the source-side circuit can be exchanged with each other. Compared to other solutions, water side reversal has the advantage of keeping the heat exchangers in counter-flow in both chiller and heat pump operating modes.

To make the cycle reversal, the fitter must install a system of valves that will allow the two circuits to be exchanged.

If the seasonal mode change is carried out via remote signal or BMS, Tetris W Rev HPW can control motor-driven reversing valves (not supplied) so as to make this operation fully automatic.

Tetris W Rev /HP is a high efficiency refrigerator-side reversible heat pump: this version always guarantees separation between source and user fluids, thus also allowing different pumps to be used on the various hydronic circuits, does not require external reversing valves and makes the installation operations easier.

Tetris W Rev LC/HP is a reversible condenserless unit that, combined with a remote reversible condenser, allows the hydronic part to be installed in a technical room inside the building and the ventilation part to be installed outside or on the roof. This allows greater flexibility on dimensions and noisiness of the ventilation part and the advantage of not being required to add glycol to the water of the user-side circuit since it is completely indoors.

Tetris W Rev

Liquid refrigerators and high efficiency heat pumps with water source, with scroll compressors in R410A for indoor installation

BODY

The structure consists of a load-bearing frame made of epoxy polyester powder coated steel sheet, coloured with RAL 7035.

All screws and bolts are stainless steel.

COMPRESSORS

The compressors are hermetic orbiting spiral scroll compressors connected in tandem or trio, fitted with oil level sight glass, oil equalization line and electronic protection.

USER-SIDE HEAT EXCHANGER

The exchanger is a braze-welded stainless steel plate heat exchanger, insulated with a shroud of closed-cell insulating material.

Models with 2 refrigerant circuits are fitted with dual circuit heat exchanger and therefore with a single pair of hydraulic connections. This has allowed us to:

- maximize the EER and COP levels
- reduce the amount of refrigerant used in the unit
- make the unit lighter and more compact
- make its maintenance easier.

The heat exchanger is fitted with a temperature probe for freeze protection and a paddle flow switch for water flow control.(supplied loose).

SOURCE-SIDE HEAT EXCHANGER

The exchanger is a braze-welded stainless steel plate heat exchanger, insulated with a shroud of closed-cell insulating material.

Models with 2 refrigerant circuits are fitted with dual circuit heat exchanger and therefore with a single pair of hydraulic connections.

For the HPW and HP version units, the heat exchanger is fitted with a temperature probe for freeze protection and a paddle flow switch for water flow control.(supplied loose).

REFRIGERANT CIRCUIT

Each refrigerant circuit of the basic unit (cooling only) comprises:

- shut-off valve in the liquid line
- 5/16" charging valves
- liquid sight glass
- replaceable solid cartridge dehydrator filter
- electronic expansion valve
- pressure transducers for reading the high and low pressure values and relevant evaporating and condensing temperatures
- high pressure switches
- low pressure switches (only for models with parametric control)

The pipes of the circuit and the exchanger are insulated with extruded closed-cell expanded elastomer.

Compared to the mechanical expansion valve, the electronic expansion valve allows machine stability to be reached more quickly and better superheating control to maximize the use of the evaporator in all load conditions. This also acts as shut-off valve on the liquid line, as it closes during compressor stops, so preventing dangerous refrigerant migration.

ELECTRICAL CONTROL PANEL

The electrical control panel is made in a painted galvanized sheet-iron box.

The electrical control panel of the basic unit comprises:

- main disconnect switch
- automatic circuit breakers for compressors with fixed calibration
- fuses to protect the auxiliary circuits
- thermal magnetic circuit breakers for the pumps (if present)
- contactors for compressors and pumps (if present)
- phase monitor
- potential-free general alarm contacts
- single potential free operating contacts for compressors and pumps (if present)
- microprocessor controller with display accessible from the outside

All the electrical cables inside the panel are numbered and the terminal board dedicated to the customer's connections is coloured blue so that it can be quickly identified in the panel.

The power supply of the unit is 400V/3~/50Hz or 400V/3~+N/50Hz depending on the model and the version

CONTROL BLUETHINK

Main controller functions parametric

This is the standard control for models from 3.2 to 27.2 in set-up base, HP, OH, LC, LC/HP. For these units, the advanced control can be ordered as an accessory.

The control allows the following functions:

- water temperature adjustment, with control of the water entering the user-side heat exchanger
- freeze protection
- compressor timings
- automatic rotation of compressor starting sequence
- recording of the alarm log
- RS485 serial port with Modbus protocol
- digital input for general ON/OFF
- digital input for Summer/Winter selection (only for HP and LC/HP units)

For further details on available functions and on displayed information, you can refer to the specific documentation of the control.

By default, the serial connections present as standard are enabled only for reading from BMS. Enabling of writing from BMS is to be requested when ordering.

Main controller functions advanced

This is the standard control for all models in HPW set-up and all models with more than two compressors.

The control allows the following functions:

- water temperature adjustment, with control of the water entering the user-side heat exchanger
- freeze protection
- compressor timings
- automatic rotation of compressor starting sequence
- recording of the log of all machine inputs, outputs and states
- automatic rotation of compressor starting sequence
- recording of the alarm log
- RS485 serial port with Modbus protocol
- Ethernet serial port with Modbus protocol and integrated web server preloaded web page
- digital input for general ON/OFF
- digital input for Summer/Winter selection (only for HP, HPW and LC/HP units)

For further details on available functions and on displayed information, you can refer to the specific documentation of the control.

By default, the serial connections present as standard are enabled only for reading from BMS. Enabling of writing from BMS is to be requested when ordering.

Main functions of the webserver (only for units with advanced control)

As standard, the Bluethink controller integrates a web-server with a preloaded web page that is accessed via password.

The web page allows the following functions to be carried out (some of these are available only for users with advanced level rights):

- display of the main functions of the unit such as unit serial n°, size, refrigerant
- display of the general status of the machine: water inlet and outlet temperatures, external air temperature, mode (chiller or heat pump), evaporating and condensing pressures, suction and discharge temperatures
- display of the status of compressors, pumps, expansion valves
- display in real time of the graphs of the main quantities
- display of the graphs of logged quantities
- display of alarm log
- management of users on several levels
- remote ON/OFF
- remote set point change
- remote time band change
- remote summer winter mode selection

Human-Machine Interface

The control has a graphic display that allows the following information to be displayed:

- water inlet and outlet temperature
- set temperature and differential set points
- description of alarms
- hour meter of operation and number of start-ups of the unit, the compressors and the pumps (if present)
- high and low pressure values, and relevant condensing and evaporating temperatures
- external air temperature
- superheating at compressor suction.

Management of defrost cycles (only for LC/HP versions)

For defrost management, the control of the unit uses a sliding intervention threshold, depending on the pressures inside the unit and the external air temperature. By putting together all this information, the control can identify the presence of ice on the coil and activates the defrosting sequence only when necessary, so as to maximize the energy efficiency of the unit.

Sliding management of the defrost threshold ensures that, as the absolute humidity of outdoor air decreases, the frequency of the defrost cycles gradually decreases because they are carried out only when the ice formed on the coil actually penalizes performance.

The defrost cycle is fully automatic and is carried out using a patented defrost system (patent n° 1335232): during the initial stage, a defrost is carried out by cycle reversal with fans stopped. When the frost on the coil has melted sufficiently, reverse ventilation is activated, that is, with air flow in the opposite direction to that of normal operation, so as to facilitate the ejection of condensed water and detached ice. When the coil is clean, ventilation is reversed again and the unit resumes operation in heat pump mode.

The combination of the sliding intervention threshold and the patented defrost system allows the number and duration of defrost cycles to be optimized and reduced to the minimum.

The above applies only when the unit is coupled to a remote condenser combined as per catalogue and supplied from the factory and when this is controlled by the internal unit.

TESTING

All the units are factory-tested and supplied complete with oil and refrigerant.

The LC and LC/HP version units are electrically tested. For on-site installation, in addition to the electrical and hydraulic connections, it will be necessary to make the refrigerant connection to the remote heat exchanger and charge with the correct refrigerant and oil charge.

PACKAGING

The unit is made and shipped on a wooden pallet that allows the unit to be handled using a forklift truck.

The unit is wrapped in transparent polyethylene stretch film.

VERSIONS

In the basic version, the unit is a high efficiency liquid chiller, but includes various types of set-up as an option to meet the requirements of all types of application.

OH: heat pump for heating only

The OH unit is a non-reversible heat pump.

HPW: heat pump with hydronic-side reversal

The HPW unit is a heat pump that includes cycle reversal on the hydronic side of the system via special 3-way or 4-way reversing valves outside the unit (not supplied).

In addition to what is present in the basic version, the HPW set-up includes an OK signal in the terminal board for controlling the group of external reversing valves (not supplied).

HP: reversible heat pump

The HP unit is a reversible heat pump with cycle reversal on the chiller side.

In addition to what is present in the basic version, the HP set-up includes:

- 4-way reversing valve
- paddle flow switch for source-side water flow control (supplied with the unit).

LC: condenserless unit

The LC unit is a condenserless unit and therefore, compared to the basic unit, is without the source-side heat exchanger and the refrigerant charge.

The unit must be connected to a suitably sized remote heat exchanger.

LC/HP: reversible condenserless unit

The LC/HP unit is a reversible condenserless unit and therefore, compared to the HP unit, is without the source-side heat exchanger and the refrigerant charge. Compared to the HP unit, it has the suction separator in addition.

The unit must be connected to a suitably sized remote heat exchanger. The heat exchanger must be suitable for operation as condenser and as evaporator and must be fitted with an expansion valve (with relevant bypass valve) sized for operation of the system in heat pump mode.

OPTIONS

/DC: unit with total recovery condenser

In addition to the set-up of a chiller only unit, /DC units include:

- a heat recovery condenser for recovering 100% of the condensation heat; The exchanger is a brazed plate heat exchanger
- temperature probe at the inlet of the heat recovery heat exchanger
- a liquid receiver for each refrigerant circuit

This set-up is not available for the OH, HPW, HP and LC/HP units.

/DS: unit with partial heat recovery

In addition to the set-up of a chiller only unit, /DS units comprise (for each refrigerant circuit) a heat exchanger for partial recovery of condensation heat, placed in series with the source-side heat exchanger. The exchanger is a braze-welded brazed plate heat exchanger

This option is also available for HPW, HP e LC/HP units, but in this case, in the installation, there must be provision for shutting off the heat recovery water circuit during operation in heat pump mode to avoid taking power from the user-side heat exchanger.

/LN: low noise unit

Units in LN set-up are fully panelled with epoxy polyester powder coated steel sheet panels coloured with RAL 7035 and lined with matting made of sound absorbing and soundproofing material.

Example of non /LN unit

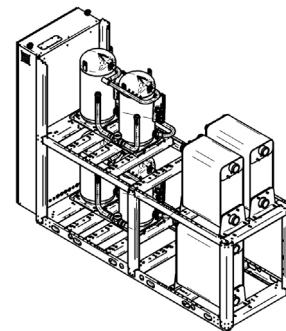

Example of /LN unit

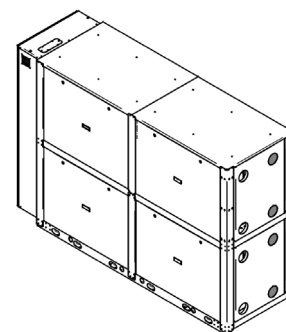

HYDRAULIC MODULES

All the units can be equipped with hydraulic module in various combinations on the user side, on the source side and in combination with the total heat recovery heat exchanger. Refer to the table of configurations that are not possible to check for availability of specific set-ups.

Hydraulic modules with one pump have:

- one pump
- a gate valve on the delivery side of the pump
- an expansion vessel

Hydraulic modules with two pumps have:

- two pumps
- a check valve on the delivery side of each pump
- a gate valve on the outlet of the delivery manifold
- an expansion vessel

In the version with 2 pumps, these are always with one on standby while the other is working. Switching over between the pumps is automatic and is done by time (to balance the hours of operation of each one) or in the event of failure.

Hydraulic modules with tank also have:

- a gate valve at the inlet of the pump or the suction manifold
- a tank with drain valve and air valve

User-side hydraulic modules

The hydraulic circuit inside the unit is fully insulated with closed-cell insulating material..

The module can have the following configurations:

- /1P: hydraulic module with one pump
- /1PS: hydraulic module with one pump and buffer tank
- /2P: hydraulic module with two pumps
- /2PS: hydraulic module with two pumps and buffer tank

All the above-mentioned modules have pumps with standard discharge head.

The following are also available:

modules /1PM, /1PMS, /2PM and /2PMS that have pumps with increased available discharge head
modules /1PG, /1PGS, /2PG and /2PGS that have pumps suitable for operating with glycol up to 50%

Source-side hydraulic modules

The source side pumps are normally switched off and they are switched on a few seconds before the start of first compressor.

When reaching the set point, a few seconds after switching off the last compressor, the source side pumps are switched off again.

The hydraulic circuit inside the unit is fully insulated with closed-cell insulating material. (only for units in HP or HPW set-up).

The module can have the following configurations:

- /1S: hydraulic module with one pump
- /2S: hydraulic module with two pumps

All the above-mentioned modules have pumps with standard discharge head.

The following are also available:

modules /1SM and /2SM that have pumps with increased available discharge head

modules /1SG and /2SG that have pumps suitable for operating with glycol up to 50%

Total heat recovery-side hydraulic modules

The hydraulic circuit inside the unit is fully insulated with closed-cell insulating material..

The module can have the following configurations:

- /1R: hydraulic module with one pump
- /2R: hydraulic module with two pumps

All the above-mentioned modules have pumps with standard discharge head.

The following are also available:

modules /1RM and /2RM that have pumps with increased available discharge head

modules /1RG and /2RG that have pumps suitable for operating with glycol up to 50%

CONTROLS AND SAFETY DEVICES

All the units are fitted with the following control and safety components:

- high pressure switch with manual reset
- high pressure safety device with automatic reset, for a limited number of occurrences, managed by the controller
- low pressure safety device with automatic reset and limited tripping managed by the controller
- high pressure safety valve
- antifreeze probe at outlet of each evaporator
- compressor overtemperature protection
- mechanical paddle flow switch (supplied loose)

DESCRIPTION OF ACCESSORIES

Refrigerant circuit accessories

The "(S)" symbol indicates that the option is present as standard in the unit, provided this is not in conflict with other selected accessories.

BC Capacitive backup battery for electronic expansion valve

When the compressors stop, the controller always closes the electronic expansion valve to prevent dangerous refrigerant migration. The presence of the backup battery ensures that the electronic valve is kept in closed position even when there is no power supply

This accessory uses a condenser, and not an ordinary battery, as energy storage: this allows it to be unaffected by the memory effect of normal batteries and eliminates its need for maintenance.

BT Backup battery for electronic expansion valve

When the compressors stop, the controller always closes the electronic expansion valve to prevent dangerous refrigerant migration. The presence of the backup battery ensures that the electronic valve is kept in closed position even when there is no power supply

BK Brine Kit

This accessory is compulsory if a water temperature set point lower than +3°C is used (if the unit is provided with double set point or variable set point, the lower set point is considered).

The accessory consists of increased insulation and suitable sizing and calibration of some components.

The inlet and outlet temperatures of the user-side exchanger must be given on ordering to allow correct setting of the alarm parameters and verification of the sizing of the expansion valve.

The cooling set point can then be changed by the customer in an interval that, compared to the set point given on ordering, ranges from -1K up to the maximum temperature allowed by the above-stated operating limits.

The unit will be optimized to work at the set point temperature given on ordering. For different set points, the cooling capacity provided and the level of efficiency of the machine could decrease and move away from these conditions.

DVS Double safety valve

With this accessory, instead of each individual safety valve per circuit, there is a "candelabrum" with two safety valves and a diverter valve for choosing the valve in operation. This allows the safety valves to be replaced without having to drain the machine and without having to stop it.

MAFR Pressure gauges

The operating pressures of each circuit of the unit can be displayed on the control by accessing the relevant screens. Also, the machine can be fitted with pressure gauges (two for each circuit) installed in a clearly visible position. These allow reading in real time of the working pressures of the refrigerant gas on the low pressure side and on the high pressure side of each refrigerant circuit.

RIC Liquid receiver

The adoption of this accessory always guarantees correct feeding of the expansion valve even when the unit is subjected to wide external air temperature ranges.

RPP Refrigerant leak detector with automatic pump down

With this accessory, a refrigerant leak detector is placed inside each compressor compartment. Detection of a refrigerant leak is managed by the control through a specific alarm and display of a specific icon on the display of the control. For all the circuits of the unit, the alarm also starts the machine stopping procedure with pump down, confining all the refrigerant in the coils.

The accessory includes the capacitive backup battery.

RPR Refrigerant leak detector

With this accessory, a refrigerant leak detector is placed inside each compressor compartment. Detection of a refrigerant leak is managed by the controller through a specific alarm and display of a specific icon on the display of the controller. This alarm stops the unit.

-
- RUB Compressor suction and delivery valves**
The valves situated on the delivery side and on the suction side of the compressors allow the compressor to be isolated from the rest of the refrigerant circuit, so making the maintenance operations quicker and less invasive
- VTE Electronic expansion valve (S)**
The use of this component is particularly advisable on units operating in very variable heat load or operating mode conditions, as in the case of joint management of air conditioning and high temperature water production. The use of an electronic thermostatic valve allows you to:
- maximize heat exchange at the evaporator
 - minimize response times to changes in load and operating conditions
 - optimize control of overheating
 - ensure maximum energy efficiency
- VP Condensation control with pressure switch valve for well water**
The accessory includes the supply of a pressure switch valve sized to operate with well water (thermal gradient of about 15K) to be installed on the source-side hydraulic circuit (installation by the customer).
A charging valve to which to connect the capillary to take to the valve is arranged on the unit, so that the modulation of its opening is based on the condensing pressure.
This accessory cannot be combined with HP or HPW version units.
- VM2 Condensation control with 2-way modulating valve**
The accessory includes the supply of a 2-way modulating valve complete with servo control to be installed on the source-side hydraulic circuit (installation by the customer). The servo control is controlled via a 0-10V signal from the control depending on the condensing pressure.
This accessory is to be used in applications where it is beneficial, when possible, to reduce the total flow rate of water coming from the source (for example, when well water is used). When the unit reaches the setpoint, the valve will be forced to close.
- VM3 Condensation control with 3-way modulating valve**
The accessory includes the supply of a 3-way modulating valve complete with servo control to be installed on the source-side hydraulic circuit (installation by the customer). The servo control is controlled via a 0-10V signal from the control depending on the condensing pressure.
This accessory is to be used in applications where it is beneficial, when possible, to reduce the flow rate of water sent to the source-side heat exchanger (for example, when water from a loop is used). When the unit reaches the set point, the valve will be forced to total recirculation.
- IPS Condensation control with source-side pump inverter ...**
This accessory can be applied only to units fitted with built-in pump on the source-side circuit. These are controlled via inverter in order to adjust the water flow rate depending on the condensing pressure.
- SIN Independent 0-10V signals for condensation control**
For each refrigerant circuit, this accessory requires a 0-10V output in the terminal board to carry out condensation control through a device outside the machine (2-way valve, 3-way valve, inverter-controlled pump). The signal is linked to the condensing pressure.
There is a signal for each refrigerant circuit and therefore the accessory is suitable for combination on units in which the sources of each circuit are managed independently.
- SCU Cumulative 0-10V signal for condensation control**
This accessory requires a 0-10V output in the terminal board to carry out condensation control through a device outside the machine (2-way valve, 3-way valve, inverter-controlled pump). The signal is linked to the condensing pressure.
The signal is cumulative and therefore the accessory is suitable for combination on units in which there is a single condensing control device located on the common branch of the source.

Hydraulic circuit accessories

Some accessories may be incompatible with each other even if not expressly indicated.

COID Upward hydraulic connections

This accessory includes the supply of the semi-finished products necessary for turning the hydraulic connections of the unit upwards. The installation of semi-finished products outside the machine is to be carried out by the customer.

Accessory supplied loose.

COL Water manifolds for DS

This accessory provides a pair of manifolds for connection of the partial heat recovery heat exchangers. The installation of the manifolds outside the machine is to be carried out by the customer.

Accessory supplied loose.

FVP FLOWZER VP - Inverter for manual pump adjustment

The accessory consists of inserting an inverter in the machine to manually adjust the speed of the pump (or pumps) in order to calibrate the pump flow rate on the head losses of the system.

This accessory is to be combined with one of the integrated hydraulic modules that can be selected for the unit. Units equipped with integrated hydraulic module allow a certain level of available discharge head (point A) to be obtained under nominal flow rate conditions Q_d .

But the actual head loss level of the system (e.g. characteristic curve R') normally causes the pump to find a different equilibrium point (point B), with a flow rate Q_r higher than Q_d .

In this condition, besides having a different flow rate from the nominal flow rate (and therefore also a different thermal gradient), there is also higher pump power absorption.

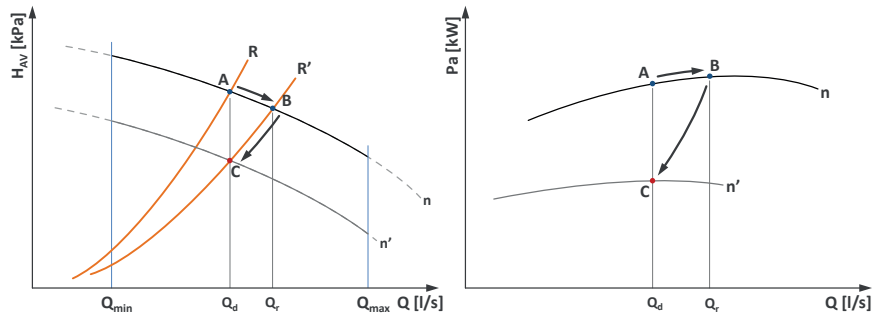

The use of the Flowzer allows the pump speed to be set manually (e.g. at speed n' instead of n) to obtain the design water flow rate and thermal gradient (point C). Once the adjustment procedure has been carried out, the pump will always work at a fixed flow rate.

Use of the Flowzer VP allows the power absorption of the pump to be considerably reduced with consequent energy saving. By way of example:

- a 10% reduction in flow rate gives a reduction in absorbed power of about 27%

FVD FLOWZER VD - Transducer for automatic adjustment

Flowzer VD requires a pressure transducer to be installed in the machine. Through this transducer, the inverter can gauge the actual pressure at the ends of the system and automatically adapt the pump speed to obtain a set available discharge head value. Flowzer VD must be combined with Flowzer VP. This accessory therefore allows a constant pressure system to be achieved.

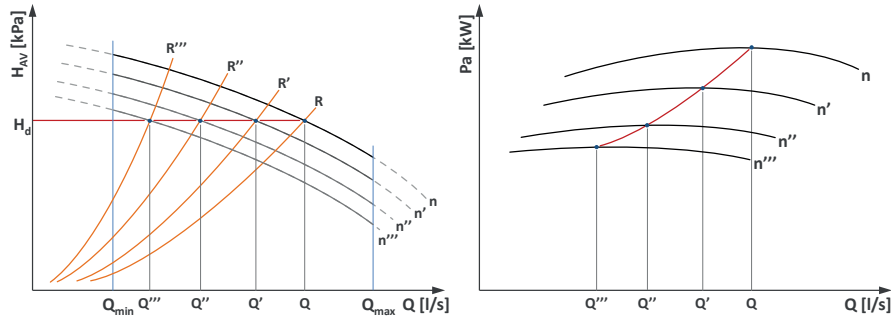

With the Flowzer VD, the customer can set, directly on the inverter, the available discharge head value H_d that the unit must maintain. As can be seen in the graph, as the system user points close, the resistance curve of the system shifts to the left and therefore the inverter will be able to reduce the pump speed in order to keep the available discharge head of the unit constant. By doing so, an immediate reduction in the power absorbed by the pump will be obtained. The customer will have to check that, in minimum flow rate conditions (that is, with the maximum number of user points closed), this is always higher than or equal to the minimum flow rate allowed by the unit.

This accessory is useful when the total head losses of the circuit are slightly variable or when they change depending on the seasons (for example, some user points are active only during summer operation and not during winter operation).

The use of this accessory also allows the pump speed to be adapted to possible fouling of the filter on the hydraulic circuit.

FVF FLOWZER VFPP – Kit for variable flow rate primary circuit pump with bypass valve included

Bluethink solution for a variable flow rate system, consisting solely of a user-side primary circuit.

Flowzer VFPP includes:

- a pressure transducer installed at the ends of the user-side exchanger (Δp_e)
- a dedicated control system, installed at the factory in the electrical control panel of the unit (Sc)
- a modulating bypass valve with servo-motor supplied separately with it (V_{bp}), supplied loose (installation by the customer)
- two system pressure transducers (Δp_p) supplied separately (installation by the customer)

It is obligatory for the option to be combined with the Flowzer VP (inverter) and with one of the hydraulic modules that can be selected for the unit. The accessory is not compatible with Multilogic (please contact our sales department for further details).

The unit must include the advanced Bluethink controller, just one heat exchanger on the user side and a minimum capacity step of 25% or less.

The option offers a complete default package to guarantee simple selection, purchasing and commissioning. In particular, the unit includes an additional control system, equipped with an advanced algorithm, which interacts with the main advanced Bluethink controller.

The Flowzer VFPP has the advantage of:

- implementing an innovative design, which is alternative to the classic system based on fixed flow-rate primary circuit plus secondary circuit
- being ideal for new or entirely redesigned systems, especially for comfort applications
- achieving a complete variable flow system, with maximum energy saving
- simplifying the layout of the user circuit
- limiting the capex of the system
- achieving complete and reliable control of the system

The maximum energy saving is achieved thanks to:

- a hydraulic decoupler managed by the modulating bypass valve, which regulates the bypass flow rate on the lowest possible value
- an advanced algorithm to prevent hunting by the reversing valve and by the bypass valve, thereby balancing the pump speed and the bypass speed to a minimum

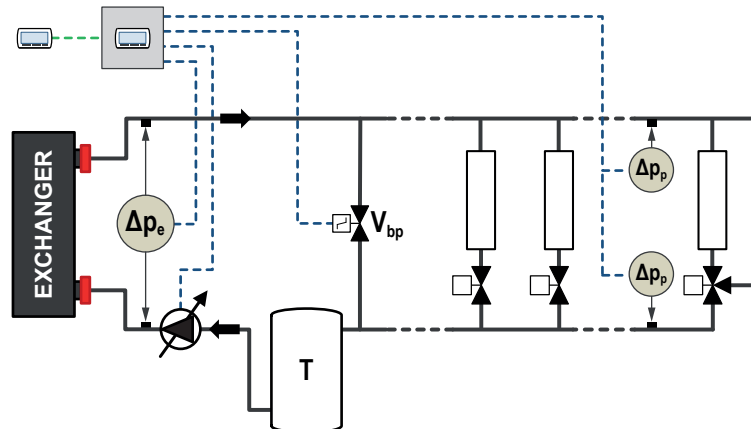

The capex of the system is also reduced thanks to:

- single inverter + pumping module, integrated in the unit
- small internal footprint, due to the simplified layout

The operating principle can be summarized as follows:

- the flowzer VFPP carries out constant control of the discharge head
- the system controller modulates the pump speed according to the condition detected by the system transducers Δp_p
- if the system terminals are switched off, the pump speed will decrease
- the pump speed can be reduced until it reaches the minimum allowed flow rate on the heat exchanger of the unit
- this flow rate is indirectly monitored through the losses detected by the differential pressure transducer Δp_e
- When the minimum allowed flow rate threshold is exceeded, the control system will open the bypass valve V_{bp} to recirculate the flow rate that is not required by the system, but is necessary to guarantee the minimum flow rate to the heat exchanger.

In the required minimum load condition (that is, with all system terminals switched off), the required minimum volume (V_{min}) must be concentrated in the relevant tank, to be installed between the unit and the bypass valve. The bypass valve V_{bp} is controlled through a 0-10 V signal and must therefore be installed within 30 m of the unit.

The pressure transducers of the system Δp_p provide a 4-20 mA signal and require two 1/4" female fittings. These transducers must be installed within 200 m of the unit, near the system terminal that is affected by the highest line head losses or in any case in a position where it is possible to measure an adequate pressure value.

Further details can be found in the relevant manual.

	Bypass valve diameter		Bypass valve diameter
18.4	2"1/2	38.4	4"
20.4	2"1/2	40.4	4"
24.4	2"1/2	48.4	4"
26.4	3"	54.4	4"
30.4	3"	56.6	5"
34.4	4"	60.6	5"

VSS Source-side safety valve

With this accessory, a safety valve is inserted in the hydraulic circuit of the unit: when the calibration pressure is reached, the valve opens and, by discharging (to be routed by the customer), prevents the system pressure from reaching limits that are dangerous for the components present in the system. The valves have positive action, that is, performance is guaranteed even if the diaphragm deteriorates or breaks.

VSWU User-side safety valve

With this accessory, a safety valve is inserted in the hydraulic circuit of the unit: when the calibration pressure is reached, the valve opens and, by discharging (to be routed by the customer), prevents the system pressure from reaching limits that are dangerous for the components present in the system. The valves have positive action, that is, performance is guaranteed even if the diaphragm deteriorates or breaks.

VSWR Heat recovery-side safety valve

With this accessory, a safety valve is inserted in the hydraulic circuit of the unit: when the calibration pressure is reached, the valve opens and, by discharging (to be routed by the customer), prevents the system pressure from reaching limits that are dangerous for the components present in the system. The valves have positive action, that is, performance is guaranteed even if the diaphragm deteriorates or breaks.

Electrical accessories

Some accessories may be incompatible with each other even if not expressly indicated.

CA Advanced control

With this accessory, the advanced control is used also for sizes/versions provided with the parametric control as standard.

CBBx Provision for Blue Box remote condenser

This accessory is compulsory when the unit is coupled to the remote condenser combined as per catalogue and supplied from the factory.

When this accessory is present, the protective devices and contactors of the remote condenser are arranged in the electrical control panel of the internal unit. If the condensation control with speed adjuster is required, this too will be installed in the electrical control panel of the internal unit.

The remote condenser obligatorily takes its power directly from the internal unit.

This accessory can be combined only with the remote condensers supplied from the factory, which comply with the combination suggested in the catalogue and are ordered at the same time as the unit. For combinations other than the factory combinations, their feasibility must be checked with our sales department.

COTW Outgoing water temperature control

With this accessory, outgoing instead of incoming water temperature control is used.

CSP Set point compensation depending on external air temperature

For units fitted with this accessory, the set point of the unit is set so that it can vary between two values, a maximum and a minimum, depending on the external air temperature. The compensation ramp and the maximum and minimum values of the set point can be changed by the user.

Unless otherwise specified in the order, the controller will be set to implement a positive compensation logic according to the temperatures shown in the following diagrams:

DAA Double power supply with automatic switching

A motor-driven automatic switch to which to connect two separate power supply lines (for example, one from the mains power line and one from the uninterruptible power supply unit) is installed in the electrical control panel of the unit.

The switching from one line to another is automatic and obligatorily requires passing through the OFF position. When this accessory is requested, the power supply of the unit must compulsorily include neutral.

DAM Double power supply with manual switching

A manual switch to which to connect two separate power supply lines (for example, one from the mains power line and one from the uninterruptible power supply unit) is installed in the electrical control panel of the unit.

The switching from one line to another is manual and obligatorily requires passing through the OFF position.

GLO Modbus Lonworks Gateway

With this accessory, a RS485/Lon gateway is installed inside the electrical control panel.

By default, the programming gives read-only access to the control of the unit. Enabling of read/write access should be requested when ordering.

IA Automatic circuit breakers

With this accessory, automatic circuit breakers are installed instead of fuses for the protection of auxiliary loads. Also, the same accessory uses automatic circuit breakers with adjustable thermal overload protection to protect the compressors.

LIID Limitation of the current absorbed by digital input

When this accessory is requested, a digital input is prepared in the terminal board to activate the forced capacity reduction of the unit to a set fixed level.

This accessory is useful when there is a need to necessarily limit the power absorbed by the unit as regards particular conditions.

We point out that, in some conditions (for example, during defrosting, oil return cycles or hourly compressor rotation procedures), the controller could force the unit to operate at full capacity for limited periods of time.

FMx Multilogic Function

The Multilogic function allows management of up to 32 units equipped with advanced Bluethink controller and connected in hydraulic parallel with each other.

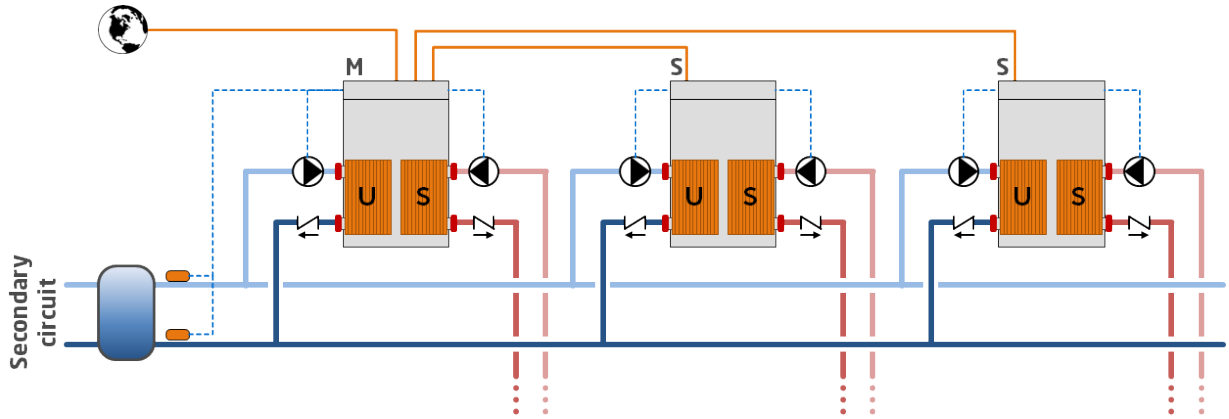

On the basis of the information recorded by the temperature probes installed on the delivery and return manifolds of the system, with the master unit, a capacity request is generated that is distributed among the units connected in the Multilogic network according to settable priority and optimization logics.

If communication between the units fails or if the master is off-line, the slave units can continue to work according to the set thermoregulation parameters.

The connected units can be different from each other, in terms of capacity and set-up, provided the following rules are complied with:

- if there are both chiller units and heat pumps in the Multilogic network, the Master unit must obligatorily be one of the HP units
- if there are both free cooling and non free-cooling units in the Multilogic network, the Master unit must obligatorily be one of the free-cooling units.

The Multilogic function that can be requested with the unit can be:

- **FM0:** Multilogic function for Slave unit
- **FM2:** Multilogic function for Master unit for managing up to 2 Slaves
- **FM6:** Multilogic function for Master unit for managing up to 6 Slaves

If you need to connect more than 6 slaves (up to 31), you can ask for a quotation from our sales department.

For the slave units, the accessory requires:

- programming of the unit as slave of a system of machines in Multilogic network

For the master units, the accessory requires:

- programming of the unit as master of a system of machines in Multilogic network
- entering of the parameters necessary for connection with the individual slave units
- installation in the electrical control panel of a network switch to allow the units to be connected in a LAN network.
- the supply of 2 temperature probes to be positioned on the delivery and return manifold of the system (supplied separately with it, installation and wiring by the customer)

The connection between the master unit and the slave units made with a CAT cable. 5E/UTP (prepared by the customer) with RJ45 connectors. Maximum cable length 100m.

For further details, please refer to the controller manual.

NSS Night Shift System

This accessory is applied to LC and LC/HP units combined with a remote condenser with speed adjuster (or EC fans) managed directly by the control of the internal unit.

In the day time band, which is normally the one with the highest heat load, priority is given to efficiency and therefore the machine works with a fan control curve that maximises the EER. So, in this time band, the unit is a high efficiency machine.

In the night time band (or in any case from the time band decided by the customer), the priority changes to limiting the noisiness of the machine and therefore the control carries out an adjustment of the control ramp of the condensing fans, thereby reducing the air flow rate and consequently the noise emission level. So, in this time band, the unit is a super low noise machine.

In any case, if there is a need for additional cooling capacity, the controller will manage the demand, if necessary, by accelerating the fans and keeping condensation within the correct operating limits.

The time slots can be set from the control depending on installation requirements.

When the unit is working in heat pump mode, in order to maximise the COP and to obtain the widest possible operating limits, the control of the unit forces the fans to the maximum speed also during the night time bands.

PBA BACnet protocol over IP (Ethernet)

The controller is set for use, in read and write mode, of the BACnet port on IP protocol.

By default, the programming gives read-only access to the control of the unit. Enabling of read/write access should be requested when ordering.

R1PU Relay for management of 1 external user-side pump

This accessory can be requested for units without user-side pumps and allows a pump outside the machine to be controlled.

R2PU Relay for management of 2 external user-side pumps

This accessory can be requested for units without user-side pumps and allows two pumps outside the machine to be controlled with a running/stand-by logic by implementing a rotation on the hours of operation.

RE1S Relay for management of 1 external source-side pump

This accessory can be requested for units without source-side pumps and allows a pump outside the machine to be controlled.

RE2S Relay for management of 2 external source-side pumps

This accessory can be requested for units without source-side pumps and allows two pumps outside the machine to be controlled with a running/stand-by logic by implementing a rotation on the hours of operation.

R1PR Relay for management of 1 external heat recovery-side pump

This accessory can be requested for units without heat recovery pumps (for DC units) and allows a pump outside the machine to be controlled.

R2PR Relay for management of 2 external heat recovery-side pumps

This accessory can be requested for units without heat recovery pumps (for DC units) and allows two pumps outside the machine to be controlled with a running/stand-by logic by implementing a rotation on the hours of operation.

RIF Power factor correction to $\cos\phi \geq 0.95$

With this accessory, an electrical control panel, containing power factor correction capacitors to make the $\cos\phi$ of the unit greater than or equal to 0.95, is supplied with the unit. The capacitors should be connected (by the customer) to the electrical control panel of the unit in the specially prepared terminal board.

Besides reducing the absorbed reactive power, the use of this accessory also allows the maximum absorbed current to be lowered.

RMFT Maximum and minimum voltage relay

This accessory constantly monitors the voltage value and the unit's power supply phase sequence. If the supply voltage does not fall within the set parameters or there is a phase reversal, an alarm is generated that stops the machine to prevent damage to its main parts

SB Heat recovery-side remote-controlled operating probe

This accessory includes the supply of a probe to be positioned in the hot tank connected to the heat recovery heat exchanger. When the set point temperature is reached in the tank, the unit also stops the pumps to guarantee the maximum energy saving.

The circulation of water in the tank to the system is to be provided by the customer.

The accessory is available only for units with DC set-up and with built-in user-side hydraulic module or with the "Relay for management of 1/2 external heat recovery-side pumps" accessory.

SFU User-side remote-controlled operating probe

With this accessory, the operating probe is to be placed on a tank outside the machine. When the set point temperature is reached in the tank, the unit also stops the pumps to guarantee the maximum energy saving.

The circulation of water in the tank to the system is to be provided by the customer.

The accessory is available only for units with built-in user-side hydraulic module or with the "Relay for management of 1/2 external user-side pumps" accessory.

SETD Double set point from digital input

The accessory allows you to preset two different operating set points and manage the change from one to the other through a digital signal.

The set point temperatures must be specified when ordering. For optimization of the unit, reference will be made to the lower set point in chiller mode and the higher set point in heat pump mode.

Unless otherwise specified in the order, the controller will be set at the factory with the following temperatures:

- in chiller mode, set point 1 to 7°C and set point 2 to 12°C
- in heat pump mode (only for HP units) set point 1 to 45°C and set point 2 to 40°C

SETV Variable set point with remote signal

The accessory allows the set point to be varied continuously between two preset values, a maximum and a minimum, depending on an external signal that can be of the 0-1V, 0-10V or 4-20mA type.

The set point temperatures and the type of signal to use for the adjustment must be specified when ordering. For optimization of the unit, reference will be made to the lower set point in chiller mode and the higher set point in heat pump mode.

Unless otherwise specified in the order, the controller will be set at the factory with 0-10V analogue input and with the following temperatures:

- in chiller mode, 0V will correspond to a set point of 7°C and 10V will correspond to a set point of 12°C
- in heat pump mode (only for HP units), 0V will correspond to a set point of 45°C and 10V will correspond to a set point of 40°C

SOFT Electronic soft-starter

The scroll compressors have DOL (Direct On Line) starting and therefore the maximum inrush current I_{MIC} will be 4/5 times its nominal current I_{nom} .

If the unit is equipped with the electronic soft-starter accessory, the starting of each compressor is done with an acceleration ramp that allows the effective value (rms value) of the inrush current of the individual compressor to be lowered.

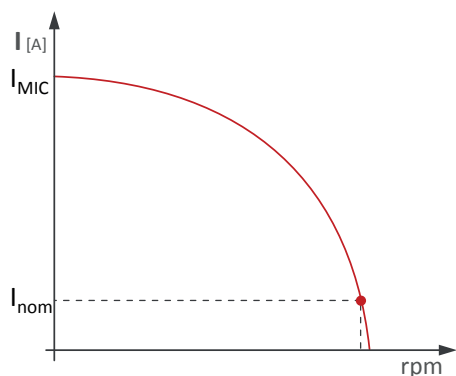

Current trend without accessory Electronic soft-starter

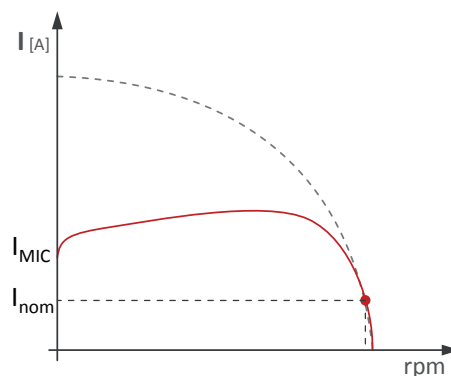

Current trend with accessory Electronic soft-starter

TERM Remote-controlled user terminal panel

This accessory allows the terminal normally situated on the machine to be replicated on a support situated at a distance. It is particularly suitable when the unit is placed in an area that is not easily accessible.

The accessory is supplied loose and is to be installed by the customer at a maximum distance of 120m from the unit. We advise using a cable of the following type: "TECO O.R. FE 2x2xAWG24 SN/ST/PUR".

PSN SNMP protocol

The accessory consists of a gateway that allows Ethernet connection to a SNMP manager supervision system. The use of this accessory causes the RS485 serial port to be unavailable.

Other accessories

The "(S)" symbol indicates that the option is present as standard in the unit, provided this is not in conflict with other selected accessories.

AG Rubber anti-vibration mounts

These allow you to reduce the vibrations transmitted from the unit to the surface it is standing on.
Accessory supplied loose.

AM Spring anti-vibration mounts

These allow you to reduce the vibrations transmitted from the unit to the surface it is standing on.
Accessory supplied loose.

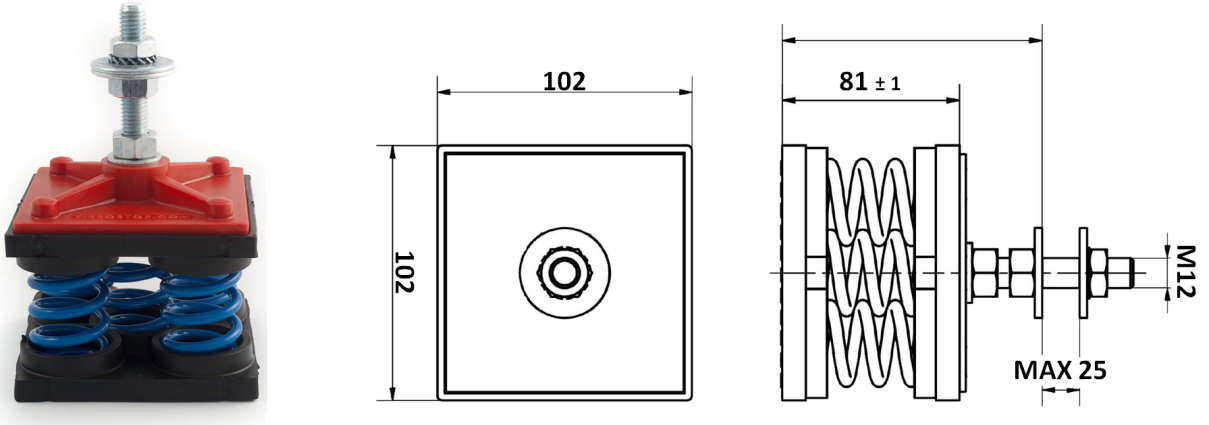

GABB Packaging in wooden crate

The unit is protected by a made-to-measure wooden crate. The accessory is mandatory if shipping by container is required.

KFW Water filter kit

To protect the elements of the hydraulic circuit (in particular, the exchangers), there are Y filters that can stop and settle the particles that are normally present in the water flow and would otherwise settle in the more delicate parts of the hydraulic circuit and damage its heat exchange capacity.

The kit involves the supply of a filter for each exchanger present in the machine.

Installation of the water filter is mandatory even when it is not supplied as an accessory.

Accessory supplied loose.

PREA Unit suitable to be disassembled on site

The unit is delivered so that it can be disassembled easily on site if this makes the installation operations easier.

A unit requested with this option is supplied:

- screwed instead of riveted
- with plugged and not welded pipes
- without refrigerant charge
- untested
- covered by the warranty only if reassembled and screwed together by personnel authorized by the factory

TECHNICAL SPECIFICATIONS

TETRIS W REV

		3.2	4.2	5.2	6.2	7.2	8.2	9.2	10.2	
Cooling (W30; W7)										
Refrigeration capacity	(1)	kW	38,2	43,4	49,8	55,2	64,0	71,9	82,0	99,6
Total absorbed power	(1)	kW	8,0	9,1	10,4	11,4	13,1	14,7	16,6	20,2
EER	(1)		4,77	4,75	4,78	4,86	4,88	4,90	4,93	4,94
ESEER			5,57	5,55	5,63	5,70	5,65	5,65	5,66	5,72
Compressors										
Compressors/Circuits		n°/n°	2/1	2/1	2/1	2/1	2/1	2/1	2/1	2/1
Minimum capacity reduction step	(8)	%	50%	50%	50%	50%	50%	50%	50%	50%
Refrigerant charge		kg	2	3	3	4	4	6	6	7
User-side heat exchanger										
Quantity		n°	1	1	1	1	1	1	1	1
Water flow rate (W30; W7)	(1)	m³/h	6,6	7,5	8,6	9,5	11,1	12,4	14,2	17,2
Head loss (W30; W7)	(1)	kPa	22	23	22	21	26	32	32	35
Source-side heat exchanger										
Quantity		n°	1	1	1	1	1	1	1	1
Water flow rate (W30; W7)	(1)	m³/h	7,9	9,0	10,3	11,4	13,2	14,8	16,9	20,5
Head loss (W30; W7)	(1)	kPa	34	39	39	42	46	33	35	36
Noise levels										
Sound power level basic unit	(4)	dB(A)	73	75	75	77	77	78	79	80
Sound pressure level basic unit	(5)	dB(A)	57	59	60	62	62	63	63	65
Sound power level LN version	(4)	dB(A)	66	68	68	70	70	71	72	73
Sound pressure level LN version	(5)	dB(A)	50	52	53	55	55	56	56	58
Dimensions and weights**										
Length		mm	1.633	1.633	1.633	1.633	1.633	1.633	1.633	1.633
Depth		mm	792	792	792	792	792	792	792	792
Height		mm	967	967	967	967	967	967	967	967
Operating weight	(6)	kg	330	340	380	400	400	440	460	470

(1) Source side heat exchanger inlet/outlet water temperature 30/35°C; user side heat exchanger inlet/outlet water temperature 12/7°C. Values compliant with standard EN 14511

(4) Unit operating at nominal operating capacity, without any accessories, with source-side heat exchanger inlet-outlet water temperature 30-35°C and user-side heat exchanger inlet-outlet water temperature 12-7°C. Binding values. Values obtained from measures taken according to standard ISO 3744 and to the Eurovent certification programme where applicable.

(5) Values obtained from the sound power level (conditions: note 4), related to a distance of 1 m from the unit in free field with directivity factor Q=2. Non-binding values.

(6) The weight refers to the unit without any accessory. The introduction of some accessories such as hydraulic modules or recovery exchangers can lead to increased weight that can exceed 10%. For further details refer to the specific drawing of the selected configuration.

(8) Approximate value. The minimum capacity reached by the unit depends on the operating conditions. The value shown may not be suitable for calculating the minimum volume of water: to do this, consult the "Minimum water content in the system" section.

** Basic CH unit without included accessories

TETRIS W REV

			12.2	13.2	15.2	17.2	19.2	20.2	24.2	27.2
Cooling (W30; W7)										
Refrigeration capacity	(1)	kW	113,0	130,5	144,3	160,5	181,9	199,5	221,3	250,7
Total absorbed power	(1)	kW	23,0	26,5	29,3	32,6	37,3	41,6	45,8	51,5
EER	(1)		4,91	4,93	4,93	4,92	4,88	4,80	4,83	4,87
ESEER			5,69	5,65	5,71	5,67	5,68	5,63	5,73	5,68
Compressors										
Compressors/Circuits		n°/n°	2/1	2/1	2/1	2/1	2/1	2/1	2/1	2/1
Minimum capacity reduction step	(8)	%	43%	50%	44%	50%	45%	50%	50%	50%
Refrigerant charge		kg	9	10	11	13	14	15	22	22
User-side heat exchanger										
Quantity		n°	1	1	1	1	1	1	1	1
Water flow rate (W30; W7)	(1)	m³/h	19,5	22,5	24,9	27,7	31,4	34,5	38,2	43,3
Head loss (W30; W7)	(1)	kPa	35	33	33	33	39	44	49	52
Source-side heat exchanger										
Quantity		n°	1	1	1	1	1	1	1	1
Water flow rate (W30; W7)	(1)	m³/h	23,3	26,9	29,7	33,1	37,5	41,3	45,8	51,8
Head loss (W30; W7)	(1)	kPa	38	40	43	46	49	51	35	36
Noise levels										
Sound power level basic unit	(4)	dB(A)	83	84	85	85	86	87	87	88
Sound pressure level basic unit	(5)	dB(A)	66	67	69	69	70	71	71	71
Sound power level LN version	(4)	dB(A)	76	77	78	78	79	80	80	81
Sound pressure level LN version	(5)	dB(A)	59	60	62	62	63	64	64	64
Dimensions and weights**										
Length		mm	1.633	1.633	1.633	1.633	1.633	1.633	1.633	1.633
Depth		mm	792	792	792	792	792	792	792	792
Height		mm	1.880	1.880	1.880	1.880	1.880	1.880	1.880	1.880
Operating weight	(6)	kg	580	670	700	740	770	800	860	880

(1) Source side heat exchanger inlet/outlet water temperature 30/35°C; user side heat exchanger inlet/outlet water temperature 12/7°C. Values compliant with standard EN 14511

(4) Unit operating at nominal operating capacity, without any accessories, with source-side heat exchanger inlet-outlet water temperature 30-35°C and user-side heat exchanger inlet-outlet water temperature 12-7°C. Binding values. Values obtained from measures taken according to standard ISO 3744 and to the Eurovent certification programme where applicable.

(5) Values obtained from the sound power level (conditions: note 4), related to a distance of 1 m from the unit in free field with directivity factor Q=2. Non-binding values.

(6) The weight refers to the unit without any accessory. The introduction of some accessories such as hydraulic modules or recovery exchangers can lead to increased weight that can exceed 10%. For further details refer to the specific drawing of the selected configuration.

(8) Approximate value. The minimum capacity reached by the unit depends on the operating conditions. The value shown may not be suitable for calculating the minimum volume of water: to do this, consult the "Minimum water content in the system" section.

** Basic CH unit without included accessories

TETRIS W REV

			30.3	34.3	40.3	18.4	20.4	24.4	26.4	30.4
Cooling (W30; W7)										
Refrigeration capacity	(1)	kW	309,2	345,0	383,5	162,6	196,8	224,7	253,1	286,8
Total absorbed power	(1)	kW	64,2	71,1	79,4	33,3	40,4	45,9	51,9	58,6
EER	(1)		4,82	4,85	4,83	4,88	4,87	4,90	4,88	4,89
ESEER			5,75	5,75	5,71	5,81	5,87	5,86	5,88	5,88
Compressors										
Compressors/Circuits		n°/n°	3/1	3/1	3/1	4/2	4/2	4/2	4/2	4/2
Minimum capacity reduction step	(8)	%	33%	33%	33%	25%	25%	21%	25%	22%
Refrigerant charge		kg	26	30	34	13	15	17	20	22
User-side heat exchanger										
Quantity		n°	1	1	1	1	1	1	1	1
Water flow rate (W30; W7)	(1)	m³/h	53,4	59,6	66,3	28,1	34,0	38,8	43,7	49,5
Head loss (W30; W7)	(1)	kPa	53	53	54	28	30	30	29	32
Source-side heat exchanger										
Quantity		n°	1	1	1	1	1	1	1	1
Water flow rate (W30; W7)	(1)	m³/h	64,0	71,3	79,3	33,6	40,7	46,4	52,3	59,2
Head loss (W30; W7)	(1)	kPa	49	41	44	32	33	38	41	44
Noise levels										
Sound power level basic unit	(4)	dB(A)	88	88	90	82	83	86	87	88
Sound pressure level basic unit	(5)	dB(A)	71	71	73	65	66	69	69	71
Sound power level LN version	(4)	dB(A)	81	81	83	75	76	79	80	81
Sound pressure level LN version	(5)	dB(A)	64	64	66	58	59	62	62	64
Dimensions and weights**										
Length		mm	2.017	2.017	2.017	2.017	2.017	2.834	2.834	2.834
Depth		mm	872	872	872	872	872	872	872	872
Height		mm	1.880	1.880	1.880	1.880	1.880	1.880	1.880	1.880
Operating weight	(6)	kg	1.220	1.260	1.340	770	800	1.030	1.210	1.270

(1) Source side heat exchanger inlet/outlet water temperature 30/35°C; user side heat exchanger inlet/outlet water temperature 12/7°C. Values compliant with standard EN 14511

(4) Unit operating at nominal operating capacity, without any accessories, with source-side heat exchanger inlet-outlet water temperature 30-35°C and user-side heat exchanger inlet-outlet water temperature 12-7°C. Binding values. Values obtained from measures taken according to standard ISO 3744 and to the Eurovent certification programme where applicable.

(5) Values obtained from the sound power level (conditions: note 4), related to a distance of 1 m from the unit in free field with directivity factor Q=2. Non-binding values.

(6) The weight refers to the unit without any accessory. The introduction of some accessories such as hydraulic modules or recovery exchangers can lead to increased weight that can exceed 10%. For further details refer to the specific drawing of the selected configuration.

(8) Approximate value. The minimum capacity reached by the unit depends on the operating conditions. The value shown may not be suitable for calculating the minimum volume of water: to do this, consult the "Minimum water content in the system" section.

** Basic CH unit without included accessories

TETRIS W REV

			34.4	38.4	40.4	48.4	54.4	56.6	60.6
Cooling (W30; W7)									
Refrigeration capacity	(1)	kW	319,0	363,3	408,4	453,8	512,9	544,8	615,0
Total absorbed power	(1)	kW	65,6	75,2	84,4	93,0	103,8	111,9	125,8
EER	(1)		4,86	4,83	4,84	4,88	4,94	4,87	4,89
ESEER			5,86	5,85	5,83	5,93	6,00	5,87	5,92
Compressors									
Compressors/Circuits		n°/n°	4/2	4/2	4/2	4/2	4/2	6/2	6/2
Minimum capacity reduction step	(8)	%	25%	23%	25%	25%	25%	15%	17%
Refrigerant charge		kg	26	45	49	37	42	44	48
User-side heat exchanger									
Quantity		n°	1	1	1	1	1	1	1
Water flow rate (W30; W7)	(1)	m³/h	55,0	62,7	70,5	78,2	88,4	93,9	106,1
Head loss (W30; W7)	(1)	kPa	31	44	46	28	30	31	34
Source-side heat exchanger									
Quantity		n°	1	1	1	1	1	1	1
Water flow rate (W30; W7)	(1)	m³/h	65,9	75,1	84,4	93,7	105,7	112,5	126,9
Head loss (W30; W7)	(1)	kPa	49	53	55	46	48	52	54
Noise levels									
Sound power level basic unit	(4)	dB(A)	88	89	90	90	91	91	91
Sound pressure level basic unit	(5)	dB(A)	71	72	72	73	73	73	73
Sound power level LN version	(4)	dB(A)	81	82	83	83	84	84	84
Sound pressure level LN version	(5)	dB(A)	64	65	65	66	66	66	66
Dimensions and weights**									
Length		mm	2.834	2.834	2.834	2.834	2.834	3.334	3.334
Depth		mm	872	872	872	872	872	872	872
Height		mm	1.880	1.880	1.880	1.880	1.880	1.880	1.880
Operating weight	(6)	kg	1.350	1.500	1.580	1.630	1.710	2.030	2.150

(1) Source side heat exchanger inlet/outlet water temperature 30/35°C; user side heat exchanger inlet/outlet water temperature 12/7°C. Values compliant with standard EN 14511

(4) Unit operating at nominal operating capacity, without any accessories, with source-side heat exchanger inlet-outlet water temperature 30-35°C and user-side heat exchanger inlet-outlet water temperature 12-7°C. Binding values. Values obtained from measures taken according to standard ISO 3744 and to the Eurovent certification programme where applicable.

(5) Values obtained from the sound power level (conditions: note 4), related to a distance of 1 m from the unit in free field with directivity factor Q=2. Non-binding values.

(6) The weight refers to the unit without any accessory. The introduction of some accessories such as hydraulic modules or recovery exchangers can lead to increased weight that can exceed 10%. For further details refer to the specific drawing of the selected configuration.

(8) Approximate value. The minimum capacity reached by the unit depends on the operating conditions. The value shown may not be suitable for calculating the minimum volume of water: to do this, consult the "Minimum water content in the system" section.

** Basic CH unit without included accessories

TETRIS W REV /HP

			3.2	4.2	5.2	6.2	7.2	8.2	9.2	10.2
Cooling (W30; W7)										
Refrigeration capacity	(1)	kW	34,8	40,0	43,2	50,6	59,3	68,0	76,2	88,7
Total absorbed power	(1)	kW	8,2	9,4	10,2	11,6	13,4	15,2	17,1	20,8
EER	(1)		4,22	4,24	4,22	4,38	4,42	4,48	4,45	4,27
ESEER			4,92	5,00	5,00	5,12	5,11	5,14	5,08	4,91
Heating (W10; W45)										
Heating capacity	(2)	kW	43,3	49,8	53,2	60,6	71,8	81,7	90,6	107,9
Total absorbed power	(2)	kW	10,1	11,6	12,3	14,1	16,5	18,9	20,9	25,0
COP	(2)		4,27	4,28	4,31	4,29	4,34	4,33	4,34	4,31
Compressors										
Compressors/Circuits		n°/n°	2/1	2/1	2/1	2/1	2/1	2/1	2/1	2/1
Minimum capacity reduction step	(8)	%	50%	50%	50%	50%	50%	50%	50%	50%
Refrigerant charge		kg	2	3	3	4	4	6	6	7
User-side heat exchanger										
Quantity		n°	1	1	1	1	1	1	1	1
Water flow rate (W30; W7)	(1)	m³/h	6,0	6,9	7,5	8,7	10,2	11,8	13,2	15,3
Head loss (W30; W7)	(1)	kPa	19	20	19	19	23	66	28	31
Water flow rate (W10; W45)	(2)	m³/h	7,4	8,5	9,1	10,4	12,3	14,0	15,5	18,5
Head loss (W10; W45)	(2)	kPa	28	30	28	26	32	40	39	45
Source-side heat exchanger										
Quantity		n°	1	1	1	1	1	1	1	1
Water flow rate (W30; W7)	(1)	m³/h	7,3	8,4	9,1	10,6	12,4	14,2	16,0	18,7
Head loss (W30; W7)	(1)	kPa	48	50	48	45	53	44	34	38
Noise levels										
Sound power level basic unit	(4)	dB(A)	73	75	75	77	77	78	79	80
Sound pressure level basic unit	(5)	dB(A)	57	59	60	62	62	63	63	65
Sound power level LN version	(4)	dB(A)	66	68	68	70	70	71	72	73
Sound pressure level LN version	(5)	dB(A)	50	52	53	55	55	56	56	58
Dimensions and weights**										
Length		mm	1.633	1.633	1.633	1.633	1.633	1.633	1.633	1.633
Depth		mm	792	792	792	792	792	792	792	792
Height		mm	967	967	967	967	967	967	967	967
Operating weight	(6)	kg	330	340	380	400	410	440	450	460

- (1) Source side heat exchanger inlet/outlet water temperature 30/35°C; user side heat exchanger inlet/outlet water temperature 12/7°C. Values compliant with standard EN 14511
- (2) Source-side heat exchanger inlet-outlet water temperature 10/7°C; user-side heat exchanger inlet-outlet water temperature 40/45°C. Values compliant with standard EN 14511
- (4) Unit operating at nominal operating capacity, without any accessories, with source-side heat exchanger inlet-outlet water temperature 30-35°C and user-side heat exchanger inlet-outlet water temperature 12-7°C. Binding values. Values obtained from measures taken according to standard ISO 3744 and to the Eurovent certification programme where applicable.
- (5) Values obtained from the sound power level (condition in note 4), referred to a distance of 1 m from the unit in free field with directivity factor Q = 2. Non-binding values.
- (6) The weight refers to the unit without any accessory. The introduction of some accessories such as hydraulic modules or recovery exchangers can lead to increased weight that can exceed 10%. For further details refer to the specific drawing of the selected configuration.
- (8) Approximate value. The minimum capacity reached by the unit depends on the operating conditions. The value shown may not be suitable for calculating the minimum volume of water: to do this, consult the "Minimum water content in the system" section.

** Basic CH unit without included accessories

TETRIS W REV /HP

			12.2	13.2	15.2	17.2	19.2	20.2	24.2	27.2
Cooling (W30; W7)										
Refrigeration capacity	(1)	kW	101,3	114,3	128,8	143,5	164,4	185,1	205,4	236,9
Total absorbed power	(1)	kW	23,6	26,4	29,8	33,1	38,0	42,6	47,8	51,7
EER	(1)		4,29	4,33	4,32	4,33	4,33	4,34	4,30	4,58
ESEER			4,94	4,93	5,00	4,94	5,00	5,06	5,07	5,19
Heating (W10; W45)										
Heating capacity	(2)	kW	122,3	137,7	155,7	173,4	198,9	223,1	251,6	282,2
Total absorbed power	(2)	kW	28,3	31,7	35,9	40,0	45,7	51,6	57,4	63,4
COP	(2)		4,32	4,34	4,34	4,33	4,35	4,32	4,38	4,45
Compressors										
Compressors/Circuits		n°/n°	2/1	2/1	2/1	2/1	2/1	2/1	2/1	2/1
Minimum capacity reduction step	(8)	%	43%	50%	44%	50%	45%	50%	50%	50%
Refrigerant charge		kg	9	10	11	13	14	15	22	22
User-side heat exchanger										
Quantity		n°	1	1	1	1	1	1	1	1
Water flow rate (W30; W7)	(1)	m³/h	17,5	19,7	22,2	24,8	28,4	32,0	35,4	40,8
Head loss (W30; W7)	(1)	kPa	30	29	29	29	34	38	33	11
Water flow rate (W10; W45)	(2)	m³/h	20,9	23,6	26,7	29,7	34,1	38,2	43,1	48,5
Head loss (W10; W45)	(2)	kPa	43	41	41	42	49	54	49	16
Source-side heat exchanger										
Quantity		n°	1	1	1	1	1	1	1	1
Water flow rate (W30; W7)	(1)	m³/h	21,4	24,1	27,2	30,3	34,7	39,0	43,4	49,6
Head loss (W30; W7)	(1)	kPa	37	35	34	35	40	45	44	14
Noise levels										
Sound power level basic unit	(4)	dB(A)	83	84	85	85	86	87	87	88
Sound pressure level basic unit	(5)	dB(A)	66	67	69	69	70	71	71	71
Sound power level LN version	(4)	dB(A)	76	77	78	78	79	80	80	81
Sound pressure level LN version	(5)	dB(A)	59	60	62	62	63	64	64	64
Dimensions and weights**										
Length		mm	1.633	1.633	1.633	1.633	1.633	1.633	2.017	2.017
Depth		mm	792	792	792	792	792	792	872	872
Height		mm	1.880	1.880	1.880	1.880	1.880	1.880	1.880	1.880
Operating weight	(6)	kg	570	660	700	730	760	800	910	960

- (1) Source side heat exchanger inlet/outlet water temperature 30/35°C; user side heat exchanger inlet/outlet water temperature 12/7°C. Values compliant with standard EN 14511
- (2) Source-side heat exchanger inlet-outlet water temperature 10/7°C; user-side heat exchanger inlet-outlet water temperature 40/45°C. Values compliant with standard EN 14511
- (4) Unit operating at nominal operating capacity, without any accessories, with source-side heat exchanger inlet-outlet water temperature 30-35°C and user-side heat exchanger inlet-outlet water temperature 12-7°C. Binding values. Values obtained from measures taken according to standard ISO 3744 and to the Eurovent certification programme where applicable.
- (5) Values obtained from the sound power level (condition in note 4), referred to a distance of 1 m from the unit in free field with directivity factor Q = 2. Non-binding values.
- (6) The weight refers to the unit without any accessory. The introduction of some accessories such as hydraulic modules or recovery exchangers can lead to increased weight that can exceed 10%. For further details refer to the specific drawing of the selected configuration.
- (8) Approximate value. The minimum capacity reached by the unit depends on the operating conditions. The value shown may not be suitable for calculating the minimum volume of water: to do this, consult the "Minimum water content in the system" section.

** Basic CH unit without included accessories

TETRIS W REV /HP

			30.3	34.3	40.3	18.4	20.4	24.4	26.4	30.4
Cooling (W30; W7)										
Refrigeration capacity	(1)	kW	283,4	311,1	349,3	150,9	179,2	204,1	229,8	268,6
Total absorbed power	(1)	kW	61,9	69,1	77,1	33,4	40,4	45,7	51,3	57,2
EER	(1)		4,58	4,50	4,53	4,52	4,43	4,47	4,48	4,70
ESEER			5,29	5,20	5,21	5,32	5,27	5,28	5,33	5,58
Heating (W10; W45)										
Heating capacity	(2)	kW	334,7	377,2	415,4	182,7	216,2	246,5	273,4	308,6
Total absorbed power	(2)	kW	74,5	85,9	94,6	40,8	48,8	55,8	62,1	69,4
COP	(2)		4,49	4,39	4,39	4,48	4,43	4,42	4,40	4,45
Compressors										
Compressors/Circuits		n°/n°	3/1	3/1	3/1	4/2	4/2	4/2	4/2	4/2
Minimum capacity reduction step	(8)	%	33%	33%	33%	25%	25%	21%	25%	22%
Refrigerant charge		kg	26	30	34	13	15	17	20	22
User-side heat exchanger										
Quantity		n°	1	1	1	1	1	1	1	1
Water flow rate (W30; W7)	(1)	m³/h	48,8	53,6	60,2	26,1	30,9	35,2	39,7	46,3
Head loss (W30; W7)	(1)	kPa	13	15	17	33	30	33	34	30
Water flow rate (W10; W45)	(2)	m³/h	57,4	64,7	71,3	31,3	37,0	42,2	46,8	52,9
Head loss (W10; W45)	(2)	kPa	18	21	23	48	44	48	47	39
Source-side heat exchanger										
Quantity		n°	1	1	1	1	1	1	1	1
Water flow rate (W30; W7)	(1)	m³/h	59,3	65,3	73,2	31,6	37,7	42,9	48,3	55,9
Head loss (W30; W7)	(1)	kPa	16	18	20	9	10	12	13	15
Noise levels										
Sound power level basic unit	(4)	dB(A)	88	88	90	82	83	86	87	88
Sound pressure level basic unit	(5)	dB(A)	71	71	73	65	66	69	69	71
Sound power level LN version	(4)	dB(A)	81	81	83	75	76	79	80	81
Sound pressure level LN version	(5)	dB(A)	64	64	66	58	59	62	62	64
Dimensions and weights**										
Length		mm	2.017	2.017	2.017	2.017	2.017	2.834	2.834	2.834
Depth		mm	872	872	872	872	872	872	872	872
Height		mm	1.880	1.880	1.880	1.880	1.880	1.880	1.880	1.880
Operating weight	(6)	kg	1.260	1.290	1.380	820	860	1.100	1.280	1.350

- (1) Source side heat exchanger inlet/outlet water temperature 30/35°C; user side heat exchanger inlet/outlet water temperature 12/7°C. Values compliant with standard EN 14511
- (2) Source-side heat exchanger inlet-outlet water temperature 10/7°C; user-side heat exchanger inlet-outlet water temperature 40/45°C. Values compliant with standard EN 14511
- (4) Unit operating at nominal operating capacity, without any accessories, with source-side heat exchanger inlet-outlet water temperature 30-35°C and user-side heat exchanger inlet-outlet water temperature 12-7°C. Binding values. Values obtained from measures taken according to standard ISO 3744 and to the Eurovent certification programme where applicable.
- (5) Values obtained from the sound power level (condition in note 4), referred to a distance of 1 m from the unit in free field with directivity factor Q = 2. Non-binding values.
- (6) The weight refers to the unit without any accessory. The introduction of some accessories such as hydraulic modules or recovery exchangers can lead to increased weight that can exceed 10%. For further details refer to the specific drawing of the selected configuration.
- (8) Approximate value. The minimum capacity reached by the unit depends on the operating conditions. The value shown may not be suitable for calculating the minimum volume of water: to do this, consult the "Minimum water content in the system" section.

** Basic CH unit without included accessories

TETRIS W REV /HP

			34.4	38.4	40.4	48.4	54.4	56.6	60.6
Cooling (W30; W7)									
Refrigeration capacity	(1)	kW	279,9	328,2	364,8	409,9	465,5	492,1	547,9
Total absorbed power	(1)	kW	66,0	73,6	84,1	95,1	105,8	111,3	125,4
EER	(1)		4,24	4,46	4,34	4,31	4,40	4,42	4,37
ESEER			5,09	5,29	5,11	5,20	5,28	5,26	5,24
Heating (W10; W45)									
Heating capacity	(2)	kW	346,1	393,2	443,7	508,0	558,1	592,3	663,3
Total absorbed power	(2)	kW	78,8	88,8	100,2	116,2	128,0	133,1	150,4
COP	(2)		4,39	4,43	4,43	4,37	4,36	4,45	4,41
Compressors									
Compressors/Circuits		n°/n°	4/2	4/2	4/2	4/2	4/2	6/2	6/2
Minimum capacity reduction step	(8)	%	25%	23%	25%	25%	25%	15%	17%
Refrigerant charge		kg	26	45	49	37	42	44	48
User-side heat exchanger									
Quantity		n°	1	1	1	1	1	1	1
Water flow rate (W30; W7)	(1)	m³/h	48,3	56,6	62,9	70,7	80,3	84,8	94,5
Head loss (W30; W7)	(1)	kPa	30	32	22	24	26	27	29
Water flow rate (W10; W45)	(2)	m³/h	59,3	67,4	76,1	87,1	95,7	101,6	113,7
Head loss (W10; W45)	(2)	kPa	46	46	32	37	37	38	43
Source-side heat exchanger									
Quantity		n°	1	1	1	1	1	1	1
Water flow rate (W30; W7)	(1)	m³/h	59,3	69,0	77,0	86,6	98,0	103,5	115,4
Head loss (W30; W7)	(1)	kPa	47	19	30	34	36	29	42
Noise levels									
Sound power level basic unit	(4)	dB(A)	88	89	90	90	91	91	91
Sound pressure level basic unit	(5)	dB(A)	71	72	72	73	73	73	73
Sound power level LN version	(4)	dB(A)	81	82	83	83	84	84	84
Sound pressure level LN version	(5)	dB(A)	64	65	65	66	66	66	66
Dimensions and weights**									
Length		mm	2.834	2.834	2.834	2.834	2.834	3.334	3.334
Depth		mm	872	872	872	872	872	872	872
Height		mm	1.880	1.880	1.880	1.880	1.880	1.880	1.880
Operating weight	(6)	kg	1.450	1.530	1.610	1.650	1.720	2.040	2.150

- (1) Source side heat exchanger inlet/outlet water temperature 30/35°C; user side heat exchanger inlet/outlet water temperature 12/7°C. Values compliant with standard EN 14511
- (2) Source-side heat exchanger inlet-outlet water temperature 10/7°C; user-side heat exchanger inlet-outlet water temperature 40/45°C. Values compliant with standard EN 14511
- (4) Unit operating at nominal operating capacity, without any accessories, with source-side heat exchanger inlet-outlet water temperature 30-35°C and user-side heat exchanger inlet-outlet water temperature 12-7°C. Binding values. Values obtained from measures taken according to standard ISO 3744 and to the Eurovent certification programme where applicable.
- (5) Values obtained from the sound power level (condition in note 4), referred to a distance of 1 m from the unit in free field with directivity factor Q = 2. Non-binding values.
- (6) The weight refers to the unit without any accessory. The introduction of some accessories such as hydraulic modules or recovery exchangers can lead to increased weight that can exceed 10%. For further details refer to the specific drawing of the selected configuration.
- (8) Approximate value. The minimum capacity reached by the unit depends on the operating conditions. The value shown may not be suitable for calculating the minimum volume of water: to do this, consult the "Minimum water content in the system" section.

** Basic CH unit without included accessories

TETRIS W REV OH

			3.2	4.2	5.2	6.2	7.2	8.2	9.2	10.2
Heating (W10; W45)										
Heating capacity	(2)	kW	41,9	48,0	52,1	60,6	69,8	77,9	88,9	107,3
Total absorbed power	(2)	kW	9,7	11,1	11,9	13,7	16,4	18,4	20,5	24,5
COP	(2)		4,30	4,32	4,37	4,43	4,26	4,24	4,34	4,38
Compressors										
Compressors/Circuits		n°/n°	2/1	2/1	2/1	2/1	2/1	2/1	2/1	2/1
Minimum capacity reduction step	(8)	%	50%	50%	50%	50%	50%	50%	50%	50%
Refrigerant charge		kg	2	3	3	4	4	6	6	7
User-side heat exchanger										
Quantity		n°	1	1	1	1	1	1	1	1
Water flow rate (W10; W45)	(2)	m³/h	7,2	8,2	8,9	10,4	11,9	13,3	15,2	18,4
Head loss (W10; W45)	(2)	kPa	28	34	31	40	45	28	35	38
Source-side heat exchanger										
Quantity		n°	1	1	1	1	1	1	1	1
Water flow rate (W10; W45)	(2)	m³/h	5,6	6,4	6,9	8,1	9,2	10,3	11,8	14,3
Head loss (W10; W45)	(2)	kPa	16	17	14	15	18	22	22	24
Noise levels										
Sound power level basic unit	(4)	dB(A)	73	75	75	77	77	78	79	80
Sound pressure level basic unit	(5)	dB(A)	57	59	60	62	62	63	63	65
Sound power level LN version	(4)	dB(A)	66	68	68	70	70	71	72	73
Sound pressure level LN version	(5)	dB(A)	50	52	53	55	55	56	56	58
Dimensions and weights**										
Length		mm	1.633	1.633	1.633	1.633	1.633	1.633	1.633	1.633
Depth		mm	792	792	792	792	792	792	792	792
Height		mm	967	967	967	967	967	967	967	967
Operating weight	(6)	kg	330	340	380	400	400	440	460	470

(2) Source-side heat exchanger inlet-outlet water temperature 10/5°C; user-side heat exchanger inlet-outlet water temperature 40/45°C. Values compliant with standard EN 14511

(4) Unit operating at nominal operating capacity, without any accessories, with source-side heat exchanger inlet-outlet water temperature 30-35°C and user-side heat exchanger inlet-outlet water temperature 12-7°C. Binding values. Values obtained from measures taken according to standard ISO 3744 and to the Eurovent certification programme where applicable.

(5) Values obtained from the sound power level (condition in note 4), referred to a distance of 1 m from the unit in free field with directivity factor Q = 2. Non-binding values.

(6) The weight refers to the unit without any accessory. The introduction of some accessories such as hydraulic modules or recovery exchangers can lead to increased weight that can exceed 10%. For further details refer to the specific drawing of the selected configuration.

(8) Approximate value. The minimum capacity reached by the unit depends on the operating conditions. The value shown may not be suitable for calculating the minimum volume of water: to do this, consult the "Minimum water content in the system" section.

** Basic CH unit without included accessories

TETRIS W REV OH

			12.2	13.2	15.2	17.2	19.2	20.2	24.2	27.2
Heating (W10; W45)										
Heating capacity	(2)	kW	121,3	136,2	155,9	173,1	196,3	216,0	241,2	271,3
Total absorbed power	(2)	kW	27,8	31,2	35,4	39,5	45,1	50,3	56,9	63,1
COP	(2)		4,36	4,37	4,40	4,38	4,36	4,29	4,24	4,30
Compressors										
Compressors/Circuits		n°/n°	2/1	2/1	2/1	2/1	2/1	2/1	2/1	2/1
Minimum capacity reduction step	(8)	%	43%	50%	44%	50%	45%	50%	50%	50%
Refrigerant charge		kg	9	10	11	13	14	15	22	22
User-side heat exchanger										
Quantity		n°	1	1	1	1	1	1	1	1
Water flow rate (W10; W45)	(2)	m³/h	20,8	23,3	26,7	29,6	33,6	37,0	41,4	46,5
Head loss (W10; W45)	(2)	kPa	34	35	44	46	44	53	30	35
Source-side heat exchanger										
Quantity		n°	1	1	1	1	1	1	1	1
Water flow rate (W10; W45)	(2)	m³/h	16,1	18,1	20,8	23,0	26,1	28,6	31,8	35,9
Head loss (W10; W45)	(2)	kPa	24	21	23	23	27	30	34	36
Noise levels										
Sound power level basic unit	(4)	dB(A)	83	84	85	85	86	87	87	88
Sound pressure level basic unit	(5)	dB(A)	66	67	69	69	70	71	71	71
Sound power level LN version	(4)	dB(A)	76	77	78	78	79	80	80	81
Sound pressure level LN version	(5)	dB(A)	59	60	62	62	63	64	64	64
Dimensions and weights**										
Length		mm	1.633	1.633	1.633	1.633	1.633	1.633	1.633	1.633
Depth		mm	792	792	792	792	792	792	792	792
Height		mm	1.880	1.880	1.880	1.880	1.880	1.880	1.880	1.880
Operating weight	(6)	kg	580	670	700	740	770	800	860	880

(2) Source-side heat exchanger inlet-outlet water temperature 10/5°C; user-side heat exchanger inlet-outlet water temperature 40/45°C. Values compliant with standard EN 14511

(4) Unit operating at nominal operating capacity, without any accessories, with source-side heat exchanger inlet-outlet water temperature 30-35°C and user-side heat exchanger inlet-outlet water temperature 12-7°C. Binding values. Values obtained from measures taken according to standard ISO 3744 and to the Eurovent certification programme where applicable.

(5) Values obtained from the sound power level (condition in note 4), referred to a distance of 1 m from the unit in free field with directivity factor Q = 2. Non-binding values.

(6) The weight refers to the unit without any accessory. The introduction of some accessories such as hydraulic modules or recovery exchangers can lead to increased weight that can exceed 10%. For further details refer to the specific drawing of the selected configuration.

(8) Approximate value. The minimum capacity reached by the unit depends on the operating conditions. The value shown may not be suitable for calculating the minimum volume of water: to do this, consult the "Minimum water content in the system" section.

** Basic CH unit without included accessories

TETRIS W REV OH

			30.3	34.3	40.3	18.4	20.4	24.4	26.4	30.4
Heating (W10; W45)										
Heating capacity	(2)	kW	338,5	385,4	428,1	175,9	212,8	242,1	271,9	309,1
Total absorbed power	(2)	kW	76,4	88,4	97,2	40,3	48,2	54,6	61,4	69,7
COP	(2)		4,43	4,36	4,40	4,37	4,41	4,44	4,43	4,44
Compressors										
Compressors/Circuits		n°/n°	3/1	3/1	3/1	4/2	4/2	4/2	4/2	4/2
Minimum capacity reduction step	(8)	%	33%	33%	33%	25%	25%	21%	25%	22%
Refrigerant charge		kg	26	30	34	13	15	17	20	22
User-side heat exchanger										
Quantity		n°	1	1	1	1	1	1	1	1
Water flow rate (W10; W45)	(2)	m³/h	58,0	66,1	73,4	30,2	36,5	41,5	46,6	53,0
Head loss (W10; W45)	(2)	kPa	37	37	39	31	28	32	37	39
Source-side heat exchanger										
Quantity		n°	1	1	1	1	1	1	1	1
Water flow rate (W10; W45)	(2)	m³/h	45,2	51,3	57,1	23,4	28,4	32,3	36,3	41,3
Head loss (W10; W45)	(2)	kPa	38	39	40	19	21	21	20	22
Noise levels										
Sound power level basic unit	(4)	dB(A)	88	88	90	82	83	86	87	88
Sound pressure level basic unit	(5)	dB(A)	71	71	73	65	66	69	69	71
Sound power level LN version	(4)	dB(A)	81	81	83	75	76	79	80	81
Sound pressure level LN version	(5)	dB(A)	64	64	66	58	59	62	62	64
Dimensions and weights**										
Length		mm	2.017	2.017	2.017	2.017	2.017	2.834	2.834	2.834
Depth		mm	872	872	872	872	872	872	872	872
Height		mm	1.880	1.880	1.880	1.880	1.880	1.880	1.880	1.880
Operating weight	(6)	kg	1.220	1.260	1.340	770	800	1.030	1.210	1.270

(2) Source-side heat exchanger inlet-outlet water temperature 10/5°C; user-side heat exchanger inlet-outlet water temperature 40/45°C. Values compliant with standard EN 14511

(4) Unit operating at nominal operating capacity, without any accessories, with source-side heat exchanger inlet-outlet water temperature 30-35°C and user-side heat exchanger inlet-outlet water temperature 12-7°C. Binding values. Values obtained from measures taken according to standard ISO 3744 and to the Eurovent certification programme where applicable.

(5) Values obtained from the sound power level (condition in note 4), referred to a distance of 1 m from the unit in free field with directivity factor Q = 2. Non-binding values.

(6) The weight refers to the unit without any accessory. The introduction of some accessories such as hydraulic modules or recovery exchangers can lead to increased weight that can exceed 10%. For further details refer to the specific drawing of the selected configuration.

(8) Approximate value. The minimum capacity reached by the unit depends on the operating conditions. The value shown may not be suitable for calculating the minimum volume of water: to do this, consult the "Minimum water content in the system" section.

** Basic CH unit without included accessories

TETRIS W REV OH

			34.4	38.4	40.4	48.4	54.4	56.6	60.6
Heating (W10; W45)									
Heating capacity	(2)	kW	346,4	393,8	442,4	495,6	553,7	590,6	665,2
Total absorbed power	(2)	kW	78,0	89,7	100,3	116,4	127,6	133,5	150,3
COP	(2)		4,44	4,39	4,41	4,26	4,34	4,42	4,43
Compressors									
Compressors/Circuits		n°/n°	4/2	4/2	4/2	4/2	4/2	6/2	6/2
Minimum capacity reduction step	(8)	%	25%	23%	25%	25%	25%	15%	17%
Refrigerant charge		kg	26	45	49	37	42	44	48
User-side heat exchanger									
Quantity		n°	1	1	1	1	1	1	1
Water flow rate (W10; W45)	(2)	m³/h	59,4	67,5	75,8	85,0	94,9	101,3	114,0
Head loss (W10; W45)	(2)	kPa	44	43	43	40	39	34	44
Source-side heat exchanger									
Quantity		n°	1	1	1	1	1	1	1
Water flow rate (W10; W45)	(2)	m³/h	46,3	52,5	59,0	65,4	73,4	78,8	88,8
Head loss (W10; W45)	(2)	kPa	22	31	32	20	21	22	24
Noise levels									
Sound power level basic unit	(4)	dB(A)	88	89	90	90	91	91	91
Sound pressure level basic unit	(5)	dB(A)	71	72	72	73	73	73	73
Sound power level LN version	(4)	dB(A)	81	82	83	83	84	84	84
Sound pressure level LN version	(5)	dB(A)	64	65	65	66	66	66	66
Dimensions and weights**									
Length		mm	2.834	2.834	2.834	2.834	2.834	3.334	3.334
Depth		mm	872	872	872	872	872	872	872
Height		mm	1.880	1.880	1.880	1.880	1.880	1.880	1.880
Operating weight	(6)	kg	1.350	1.500	1.580	1.630	1.710	2.030	2.150

(2) Source-side heat exchanger inlet-outlet water temperature 10/5°C; user-side heat exchanger inlet-outlet water temperature 40/45°C. Values compliant with standard EN 14511

(4) Unit operating at nominal operating capacity, without any accessories, with source-side heat exchanger inlet-outlet water temperature 30-35°C and user-side heat exchanger inlet-outlet water temperature 12-7°C. Binding values. Values obtained from measures taken according to standard ISO 3744 and to the Eurovent certification programme where applicable.

(5) Values obtained from the sound power level (condition in note 4), referred to a distance of 1 m from the unit in free field with directivity factor Q = 2. Non-binding values.

(6) The weight refers to the unit without any accessory. The introduction of some accessories such as hydraulic modules or recovery exchangers can lead to increased weight that can exceed 10%. For further details refer to the specific drawing of the selected configuration.

(8) Approximate value. The minimum capacity reached by the unit depends on the operating conditions. The value shown may not be suitable for calculating the minimum volume of water: to do this, consult the "Minimum water content in the system" section.

** Basic CH unit without included accessories

TETRIS W REV HPW

			3.2	4.2	5.2	6.2	7.2	8.2	9.2	10.2
Cooling (W30; W7)										
Refrigeration capacity	(1)	kW	38,2	43,4	49,8	55,2	64,0	71,9	82,0	99,6
Total absorbed power	(1)	kW	8,0	9,1	10,4	11,4	13,1	14,7	16,6	20,2
EER	(1)		4,77	4,75	4,78	4,86	4,88	4,90	4,93	4,94
ESEER			5,57	5,55	5,63	5,70	5,65	5,65	5,66	5,72
Heating (W10; W45)										
Heating capacity	(2)	kW	41,9	48,0	52,1	60,7	69,8	78,0	88,9	107,3
Total absorbed power	(2)	kW	9,8	11,2	12,0	13,8	16,5	18,5	20,5	24,6
COP	(2)		4,28	4,30	4,35	4,41	4,24	4,22	4,33	4,36
Compressors										
Compressors/Circuits		n°/n°	2/1	2/1	2/1	2/1	2/1	2/1	2/1	2/1
Minimum capacity reduction step	(8)	%	50%	50%	50%	50%	50%	50%	50%	50%
Refrigerant charge		kg	2	3	3	4	4	6	6	7
Evaporator										
Quantity		n°	1	1	1	1	1	1	1	1
Water flow rate (W30; W7)	(1)	m³/h	6,6	7,5	8,6	9,5	11,1	12,4	14,2	17,2
Head loss (W30; W7)	(1)	kPa	22	23	22	21	26	32	32	35
Condenser										
Quantity		n°	1	1	1	1	1	1	1	1
Water flow rate (W30; W7)	(1)	m³/h	7,9	9,0	10,3	11,4	13,2	14,8	16,9	20,5
Head loss (W30; W7)	(1)	kPa	34	39	39	42	46	33	35	36
Noise levels										
Sound power level basic unit	(4)	dB(A)	73	75	75	77	77	78	79	80
Sound pressure level basic unit	(5)	dB(A)	57	59	60	62	62	63	63	65
Sound power level LN version	(4)	dB(A)	66	68	68	70	70	71	72	73
Sound pressure level LN version	(5)	dB(A)	50	52	53	55	55	56	56	58
Dimensions and weights**										
Length		mm	1.620	1.620	1.620	1.620	1.620	1.620	1.620	1.620
Depth		mm	800	800	800	800	800	800	800	800
Height		mm	1.012	1.012	1.012	1.012	1.012	1.012	1.012	1.012
Operating weight	(6)	kg	330	340	380	400	400	440	460	470

- (1) Source side heat exchanger inlet/outlet water temperature 30/35°C; user side heat exchanger inlet/outlet water temperature 12/7°C. Values compliant with standard EN 14511
- (2) Source-side heat exchanger inlet-outlet water temperature 10/7°C; user-side heat exchanger inlet-outlet water temperature 40/45°C. Values compliant with standard EN 14511
- (4) Unit operating at nominal operating capacity, without any accessories, with source-side heat exchanger inlet-outlet water temperature 30-35°C and user-side heat exchanger inlet-outlet water temperature 12-7°C. Binding values. Values obtained from measures taken according to standard ISO 3744 and to the Eurovent certification programme where applicable.
- (5) Values obtained from the sound power level (condition in note 4), referred to a distance of 1 m from the unit in free field with directivity factor Q = 2. Non-binding values.
- (6) The weight refers to the unit without any accessory. The introduction of some accessories such as hydraulic modules or recovery exchangers can lead to increased weight that can exceed 10%. For further details refer to the specific drawing of the selected configuration.
- (8) Approximate value. The minimum capacity reached by the unit depends on the operating conditions. The value shown may not be suitable for calculating the minimum volume of water: to do this, consult the "Minimum water content in the system" section.

** Basic CH unit without included accessories

TETRIS W REV HPW

			12.2	13.2	15.2	17.2	19.2	20.2	24.2	27.2
Cooling (W30; W7)										
Refrigeration capacity	(1)	kW	113,0	130,5	144,3	160,5	181,9	199,5	221,3	250,7
Total absorbed power	(1)	kW	23,0	26,5	29,3	32,6	37,3	41,6	45,8	51,5
EER	(1)		4,91	4,93	4,93	4,92	4,88	4,80	4,83	4,87
ESEER			5,69	5,65	5,71	5,67	5,68	5,63	5,73	5,68
Heating (W10; W45)										
Heating capacity	(2)	kW	121,3	136,2	155,9	173,1	196,4	216,0	241,3	271,3
Total absorbed power	(2)	kW	28,0	31,4	35,5	39,6	45,3	50,4	57,2	63,3
COP	(2)		4,34	4,34	4,39	4,37	4,34	4,28	4,22	4,29
Compressors										
Compressors/Circuits		n°/n°	2/1	2/1	2/1	2/1	2/1	2/1	2/1	2/1
Minimum capacity reduction step	(8)	%	43%	50%	44%	50%	45%	50%	50%	50%
Refrigerant charge		kg	9	10	11	13	14	15	22	22
Evaporator										
Quantity		n°	1	1	1	1	1	1	1	1
Water flow rate (W30; W7)	(1)	m³/h	19,5	22,5	24,9	27,7	31,4	34,5	38,2	43,3
Head loss (W30; W7)	(1)	kPa	35	33	33	33	39	44	49	52
Condenser										
Quantity		n°	1	1	1	1	1	1	1	1
Water flow rate (W30; W7)	(1)	m³/h	23,3	26,9	29,7	33,1	37,5	41,3	45,8	51,8
Head loss (W30; W7)	(1)	kPa	38	40	43	46	49	51	35	36
Noise levels										
Sound power level basic unit	(4)	dB(A)	83	84	85	85	86	87	87	88
Sound pressure level basic unit	(5)	dB(A)	66	67	69	69	70	71	71	71
Sound power level LN version	(4)	dB(A)	76	77	78	78	79	80	80	81
Sound pressure level LN version	(5)	dB(A)	59	60	62	62	63	64	64	64
Dimensions and weights**										
Length		mm	1.620	1.620	1.620	1.620	1.620	1.620	2.005	2.005
Depth		mm	800	800	800	800	800	800	880	880
Height		mm	1.880	1.880	1.880	1.880	1.880	1.880	1.880	1.880
Operating weight	(6)	kg	580	670	700	740	770	800	860	880

- (1) Source side heat exchanger inlet/outlet water temperature 30/35°C; user side heat exchanger inlet/outlet water temperature 12/7°C. Values compliant with standard EN 14511
- (2) Source-side heat exchanger inlet-outlet water temperature 10/7°C; user-side heat exchanger inlet-outlet water temperature 40/45°C. Values compliant with standard EN 14511
- (4) Unit operating at nominal operating capacity, without any accessories, with source-side heat exchanger inlet-outlet water temperature 30-35°C and user-side heat exchanger inlet-outlet water temperature 12-7°C. Binding values. Values obtained from measures taken according to standard ISO 3744 and to the Eurovent certification programme where applicable.
- (5) Values obtained from the sound power level (condition in note 4), referred to a distance of 1 m from the unit in free field with directivity factor Q = 2. Non-binding values.
- (6) The weight refers to the unit without any accessory. The introduction of some accessories such as hydraulic modules or recovery exchangers can lead to increased weight that can exceed 10%. For further details refer to the specific drawing of the selected configuration.
- (8) Approximate value. The minimum capacity reached by the unit depends on the operating conditions. The value shown may not be suitable for calculating the minimum volume of water: to do this, consult the "Minimum water content in the system" section.

** Basic CH unit without included accessories

TETRIS W REV HPW

			30.3	34.3	40.3	18.4	20.4	24.4	26.4	30.4
Cooling (W30; W7)										
Refrigeration capacity	(1)	kW	309,2	345,0	383,5	162,6	196,8	224,7	253,1	286,8
Total absorbed power	(1)	kW	64,2	71,1	79,4	33,3	40,4	45,9	51,9	58,7
EER	(1)		4,82	4,85	4,83	4,88	4,87	4,90	4,88	4,89
ESEER			5,75	5,75	5,71	5,81	5,87	5,86	5,88	5,88
Heating (W10; W45)										
Heating capacity	(2)	kW	338,8	385,5	428,2	175,9	212,8	242,2	272,0	309,2
Total absorbed power	(2)	kW	77,0	88,8	97,7	40,4	48,4	54,8	61,7	69,9
COP	(2)		4,40	4,34	4,38	4,35	4,40	4,42	4,41	4,42
Compressors										
Compressors/Circuits		n°/n°	3/1	3/1	3/1	4/2	4/2	4/2	4/2	4/2
Minimum capacity reduction step	(8)	%	33%	33%	33%	25%	25%	21%	25%	22%
Refrigerant charge		kg	26	30	34	13	15	17	20	22
Evaporator										
Quantity		n°	1	1	1	1	1	1	1	1
Water flow rate (W30; W7)	(1)	m³/h	53,4	59,6	66,3	28,1	34,0	38,8	43,7	49,5
Head loss (W30; W7)	(1)	kPa	53	53	54	28	30	30	29	32
Condenser										
Quantity		n°	1	1	1	1	1	1	1	1
Water flow rate (W30; W7)	(1)	m³/h	64,0	71,3	79,3	33,6	40,7	46,4	52,3	59,2
Head loss (W30; W7)	(1)	kPa	49	41	44	32	33	38	41	44
Noise levels										
Sound power level basic unit	(4)	dB(A)	88	88	90	82	83	86	87	88
Sound pressure level basic unit	(5)	dB(A)	71	71	73	65	66	69	69	71
Sound power level LN version	(4)	dB(A)	81	81	83	75	76	79	80	81
Sound pressure level LN version	(5)	dB(A)	64	64	66	58	59	62	62	64
Dimensions and weights**										
Length		mm	2.005	2.005	2.005	2.005	2.005	2.820	2.820	2.820
Depth		mm	880	880	880	880	880	880	880	880
Height		mm	1.880	1.880	1.880	1.880	1.880	1.880	1.880	1.880
Operating weight	(6)	kg	1.220	1.260	1.340	770	800	1.030	1.210	1.270

- (1) Source side heat exchanger inlet/outlet water temperature 30/35°C; user side heat exchanger inlet/outlet water temperature 12/7°C. Values compliant with standard EN 14511
- (2) Source-side heat exchanger inlet-outlet water temperature 10/7°C; user-side heat exchanger inlet-outlet water temperature 40/45°C. Values compliant with standard EN 14511
- (4) Unit operating at nominal operating capacity, without any accessories, with source-side heat exchanger inlet-outlet water temperature 30-35°C and user-side heat exchanger inlet-outlet water temperature 12-7°C. Binding values. Values obtained from measures taken according to standard ISO 3744 and to the Eurovent certification programme where applicable.
- (5) Values obtained from the sound power level (condition in note 4), referred to a distance of 1 m from the unit in free field with directivity factor Q = 2. Non-binding values.
- (6) The weight refers to the unit without any accessory. The introduction of some accessories such as hydraulic modules or recovery exchangers can lead to increased weight that can exceed 10%. For further details refer to the specific drawing of the selected configuration.
- (8) Approximate value. The minimum capacity reached by the unit depends on the operating conditions. The value shown may not be suitable for calculating the minimum volume of water: to do this, consult the "Minimum water content in the system" section.

** Basic CH unit without included accessories

TETRIS W REV HPW

			34.4	38.4	40.4	48.4	54.4	56.6	60.6
Cooling (W30; W7)									
Refrigeration capacity	(1)	kW	319,0	363,3	408,4	453,8	512,9	544,8	615,0
Total absorbed power	(1)	kW	65,6	75,2	84,4	93,0	103,8	111,9	125,8
EER	(1)		4,86	4,83	4,84	4,88	4,94	4,87	4,89
ESEER			5,86	5,85	5,83	5,93	6,00	5,87	5,92
Heating (W10; W45)									
Heating capacity	(2)	kW	346,5	394,1	442,7	495,8	554,1	591,3	665,7
Total absorbed power	(2)	kW	78,3	90,2	101,0	116,8	128,2	134,5	151,1
COP	(2)		4,42	4,37	4,38	4,25	4,32	4,40	4,41
Compressors									
Compressors/Circuits		n°/n°	4/2	4/2	4/2	4/2	4/2	6/2	6/2
Minimum capacity reduction step	(8)	%	25%	23%	25%	25%	25%	15%	17%
Refrigerant charge		kg	26	45	49	37	42	44	48
Evaporator									
Quantity		n°	1	1	1	1	1	1	1
Water flow rate (W30; W7)	(1)	m³/h	55,0	62,7	70,5	78,2	88,4	93,9	106,1
Head loss (W30; W7)	(1)	kPa	31	44	46	28	30	31	34
Condenser									
Quantity		n°	1	1	1	1	1	1	1
Water flow rate (W30; W7)	(1)	m³/h	65,9	75,1	84,4	93,7	105,7	112,5	126,9
Head loss (W30; W7)	(1)	kPa	49	53	55	46	48	52	54
Noise levels									
Sound power level basic unit	(4)	dB(A)	88	89	90	90	91	91	91
Sound pressure level basic unit	(5)	dB(A)	71	72	72	73	73	73	73
Sound power level LN version	(4)	dB(A)	81	82	83	83	84	84	84
Sound pressure level LN version	(5)	dB(A)	64	65	65	66	66	66	66
Dimensions and weights**									
Length		mm	2.820	2.820	2.820	2.820	2.820	3.320	3.320
Depth		mm	880	880	880	880	880	880	880
Height		mm	1.880	1.880	1.880	1.880	1.880	1.880	1.880
Operating weight	(6)	kg	1.350	1.500	1.580	1.630	1.710	2.030	2.150

- (1) Source side heat exchanger inlet/outlet water temperature 30/35°C; user side heat exchanger inlet/outlet water temperature 12/7°C. Values compliant with standard EN 14511
- (2) Source-side heat exchanger inlet-outlet water temperature 10/7°C; user-side heat exchanger inlet-outlet water temperature 40/45°C. Values compliant with standard EN 14511
- (4) Unit operating at nominal operating capacity, without any accessories, with source-side heat exchanger inlet-outlet water temperature 30-35°C and user-side heat exchanger inlet-outlet water temperature 12-7°C. Binding values. Values obtained from measures taken according to standard ISO 3744 and to the Eurovent certification programme where applicable.
- (5) Values obtained from the sound power level (condition in note 4), referred to a distance of 1 m from the unit in free field with directivity factor Q = 2. Non-binding values.
- (6) The weight refers to the unit without any accessory. The introduction of some accessories such as hydraulic modules or recovery exchangers can lead to increased weight that can exceed 10%. For further details refer to the specific drawing of the selected configuration.
- (8) Approximate value. The minimum capacity reached by the unit depends on the operating conditions. The value shown may not be suitable for calculating the minimum volume of water: to do this, consult the "Minimum water content in the system" section.

** Basic CH unit without included accessories

TETRIS W REV LC

			3.2	4.2	5.2	6.2	7.2	8.2	9.2	10.2
Cooling (C50; W7)										
Refrigeration capacity	(1)	kW	30,4	35,1	37,1	44,5	51,5	59,4	67,0	78,4
Total absorbed power	(1)	kW	10,2	11,7	12,5	14,3	16,9	18,9	21,0	25,0
EER	(1)		2,97	2,99	2,97	3,11	3,05	3,15	3,20	3,14
Heating (E-5; W45)										
Heating capacity	(2)	kW	34,3	39,2	41,8	47,9	56,7	64,6	71,8	85,2
Total absorbed power	(2)	kW	9,7	11,1	11,8	13,6	16,0	18,2	20,0	23,6
COP	(2)		3,54	3,55	3,56	3,51	3,53	3,55	3,59	3,62
Compressors										
Compressors/Circuits		n°/n°	2/1	2/1	2/1	2/1	2/1	2/1	2/1	2/1
Minimum capacity reduction step	(8)	%	50%	50%	50%	50%	50%	50%	50%	50%
User-side heat exchanger										
Quantity		n°	1	1	1	1	1	1	1	1
Water flow rate (C50; W7)	(1)	m³/h	5,3	6,1	6,4	7,7	8,9	10,3	11,6	13,5
Head loss (C50; W7)	(1)	kPa	33	28	30	26	34	25	29	29
Water flow rate (E-5; W45)	(1)	m³/h	5,9	6,7	7,2	8,2	9,7	11,1	12,3	14,6
Head loss (E-5; W45)	(1)	kPa	41	34	37	29	40	29	32	33
Noise levels										
Sound power level basic unit	(4)	dB(A)	73	75	75	77	77	78	79	80
Sound pressure level basic unit	(5)	dB(A)	57	59	60	62	62	63	63	65
Sound power level LN version	(4)	dB(A)	66	68	68	70	70	71	72	73
Sound pressure level LN version	(5)	dB(A)	50	52	53	55	55	56	56	58
Dimensions and weights**										
Length		mm	1.633	1.633	1.633	1.633	1.633	1.633	1.633	1.633
Depth		mm	792	792	792	792	792	792	792	792
Height		mm	967	967	967	967	967	1.880	1.880	1.880
Diameters of refrigerant connections										
Suction line diameter		mm	28	35	35	42	42	42	42	42
Liquid line diameter		mm	16	18	18	22	22	28	28	28

(1) Condensing temperature 50°C; user-side heat exchanger inlet-outlet water temperature 12/7°C. Values compliant with standard EN 14511

(2) Evaporating temperature -5°C; user-side heat exchanger inlet-outlet water temperature 40/45°C. Values compliant with standard EN 14511

(4) Sound power level obtained from measurements carried out in accordance with standard ISO 3744. Reference conditions: source side heat exchanger inlet/outlet water temperature 30/35°C; user side heat exchanger inlet/outlet water temperature 12/7°C

(5) Sound pressure level measured at a distance of 1 metre from the unit in free field, with directivity factor Q=2. Reference conditions: source side heat exchanger inlet/outlet water temperature 30/35°C; user side heat exchanger inlet/outlet water temperature 12/7°C

(6) The weight refers to the unit without any accessory. The introduction of some accessories such as hydraulic modules or recovery exchangers can lead to increased weight that can exceed 10%. For further details refer to the specific drawing of the selected configuration.

(8) Approximate value. The minimum capacity reached by the unit depends on the operating conditions. The value shown may not be suitable for calculating the minimum volume of water: to do this, consult the "Minimum water content in the system" section.

** Basic CH unit without included accessories

TETRIS W REV LC

			12.2	13.2	15.2	17.2	19.2	20.2	24.2	27.2
Cooling (C50; W7)										
Refrigeration capacity	(1)	kW	89,1	100,2	113,5	126,4	145,1	163,3	180,4	214,5
Total absorbed power	(1)	kW	28,6	32,0	36,3	40,5	46,0	51,7	60,1	66,0
EER	(1)		3,12	3,13	3,13	3,12	3,15	3,16	3,00	3,25
Heating (E-5; W45)										
Heating capacity	(2)	kW	96,5	108,1	122,8	137,4	157,0	176,4	198,5	221,6
Total absorbed power	(2)	kW	27,1	30,4	34,7	38,8	44,2	49,9	56,3	62,5
COP	(2)		3,56	3,55	3,54	3,54	3,55	3,53	3,53	3,55
Compressors										
Compressors/Circuits		n°/n°	2/1	2/1	2/1	2/1	2/1	2/1	2/1	2/1
Minimum capacity reduction step	(8)	%	43%	50%	44%	50%	45%	50%	50%	50%
User-side heat exchanger										
Quantity		n°	1	1	1	1	1	1	1	1
Water flow rate (C50; W7)	(1)	m³/h	15,4	17,3	19,6	21,8	25,1	28,2	31,1	37,0
Head loss (C50; W7)	(1)	kPa	37	31	33	34	33	42	24	23
Water flow rate (E-5; W45)	(1)	m³/h	16,5	18,5	21,0	23,5	26,9	30,2	34,0	38,0
Head loss (E-5; W45)	(1)	kPa	42	35	38	40	39	48	29	24
Noise levels										
Sound power level basic unit	(4)	dB(A)	83	84	85	85	86	87	87	88
Sound pressure level basic unit	(5)	dB(A)	66	67	69	69	70	71	71	71
Sound power level LN version	(4)	dB(A)	76	77	78	78	79	80	80	81
Sound pressure level LN version	(5)	dB(A)	59	60	62	62	63	64	64	64
Dimensions and weights**										
Length		mm	1.633	1.633	1.633	1.633	1.633	1.633	2.017	2.017
Depth		mm	792	792	792	792	792	792	872	872
Height		mm	1.880	1.880	1.880	1.880	1.880	1.880	1.880	1.880
Diameters of refrigerant connections										
Suction line diameter		mm	42	54	54	54	67	67	67	67
Liquid line diameter		mm	28	35	35	35	35	35	35	35

- (1) Condensing temperature 50°C; user-side heat exchanger inlet-outlet water temperature 12/7°C. Values compliant with standard EN 14511
- (2) Evaporating temperature -5°C; user-side heat exchanger inlet-outlet water temperature 40/45°C. Values compliant with standard EN 14511
- (4) Sound power level obtained from measurements carried out in accordance with standard ISO 3744. Reference conditions: source side heat exchanger inlet/outlet water temperature 30/35°C; user side heat exchanger inlet/outlet water temperature 12/7°C
- (5) Sound pressure level measured at a distance of 1 metre from the unit in free field, with directivity factor Q=2. Reference conditions: source side heat exchanger inlet/outlet water temperature 30/35°C; user side heat exchanger inlet/outlet water temperature 12/7°C
- (6) The weight refers to the unit without any accessory. The introduction of some accessories such as hydraulic modules or recovery exchangers can lead to increased weight that can exceed 10%. For further details refer to the specific drawing of the selected configuration.
- (8) Approximate value. The minimum capacity reached by the unit depends on the operating conditions. The value shown may not be suitable for calculating the minimum volume of water: to do this, consult the "Minimum water content in the system" section.

** Basic CH unit without included accessories

TETRIS W REV LC

			30.3	34.3	40.3	18.4	20.4	24.4	26.4	30.4
Cooling (C50; W7)										
Refrigeration capacity	(1)	kW	248,4	270,9	302,8	134,3	158,2	178,8	201,0	232,9
Total absorbed power	(1)	kW	77,3	90,0	98,9	41,7	49,6	56,7	63,7	72,1
EER	(1)		3,21	3,01	3,06	3,22	3,19	3,16	3,15	3,23
Heating (E-5; W45)										
Heating capacity	(2)	kW	262,5	299,1	333,0	144,5	169,6	193,2	210,1	243,2
Total absorbed power	(2)	kW	73,1	85,5	93,2	40,2	47,4	54,1	66,1	67,7
COP	(2)		3,59	3,50	3,57	3,59	3,58	3,57	3,18	3,59
Compressors										
Compressors/Circuits		n°/n°	3/1	3/1	3/1	4/2	4/2	4/2	4/2	4/2
Minimum capacity reduction step	(8)	%	67%	67%	67%	25%	25%	21%	25%	22%
User-side heat exchanger										
Quantity		n°	1	1	1	1	1	1	1	1
Water flow rate (C50; W7)	(1)	m³/h	42,9	46,7	52,2	23,2	27,3	30,9	34,7	40,2
Head loss (C50; W7)	(1)	kPa	30	26	30	24	23	24	25	24
Water flow rate (E-5; W45)	(1)	m³/h	45,0	51,3	57,1	24,8	29,1	33,1	36,0	41,7
Head loss (E-5; W45)	(1)	kPa	33	31	36	27	26	28	27	26
Noise levels										
Sound power level basic unit	(4)	dB(A)	88	88	90	82	83	86	87	88
Sound pressure level basic unit	(5)	dB(A)	71	71	73	65	66	69	69	71
Sound power level LN version	(4)	dB(A)	81	81	83	75	76	79	80	81
Sound pressure level LN version	(5)	dB(A)	64	64	66	58	59	62	62	64
Dimensions and weights**										
Length		mm	2.017	2.017	2.017	2.017	2.017	2.834	2.834	2.834
Depth		mm	872	872	872	872	872	872	872	872
Height		mm	1.880	1.880	1.880	1.880	1.880	1.880	1.880	1.880
Diameters of refrigerant connections										
Suction line diameter		mm	67	76	76	42	42	42	54	54
Liquid line diameter		mm	42	42	42	28	28	28	35	35

(1) Condensing temperature 50°C; user-side heat exchanger inlet-outlet water temperature 12/7°C. Values compliant with standard EN 14511

(2) Evaporating temperature -5°C; user-side heat exchanger inlet-outlet water temperature 40/45°C. Values compliant with standard EN 14511

(4) Sound power level obtained from measurements carried out in accordance with standard ISO 3744. Reference conditions: source side heat exchanger inlet/outlet water temperature 30/35°C; user side heat exchanger inlet/outlet water temperature 12/7°C

(5) Sound pressure level measured at a distance of 1 metre from the unit in free field, with directivity factor Q=2. Reference conditions: source side heat exchanger inlet/outlet water temperature 30/35°C; user side heat exchanger inlet/outlet water temperature 12/7°C

(6) The weight refers to the unit without any accessory. The introduction of some accessories such as hydraulic modules or recovery exchangers can lead to increased weight that can exceed 10%. For further details refer to the specific drawing of the selected configuration.

(8) Approximate value. The minimum capacity reached by the unit depends on the operating conditions. The value shown may not be suitable for calculating the minimum volume of water: to do this, consult the "Minimum water content in the system" section.

** Basic CH unit without included accessories

TETRIS W REV LC

			34.4	38.4	40.4	48.4	54.4	56.6	60.6
Cooling (C50; W7)									
Refrigeration capacity	(1)	kW	246,7	287,3	325,3	363,8	410,7	436,2	483,8
Total absorbed power	(1)	kW	80,6	91,7	102,7	119,8	131,5	137,4	154,0
EER	(1)		3,06	3,13	3,17	3,04	3,12	3,18	3,14
Heating (E-5; W45)									
Heating capacity	(2)	kW	275,6	310,4	349,6	403,1	442,9	466,5	524,7
Total absorbed power	(2)	kW	77,1	87,4	97,2	114,5	124,7	129,2	145,8
COP	(2)		3,58	3,55	3,60	3,52	3,55	3,61	3,60
Compressors									
Compressors/Circuits		n°/n°	4/2	4/2	4/2	4/2	4/2	6/2	6/2
Minimum capacity reduction step	(8)	%	25%	23%	25%	25%	25%	30%	33%
User-side heat exchanger									
Quantity		n°	1	1	1	1	1	1	1
Water flow rate (C50; W7)	(1)	m³/h	42,6	49,5	56,1	62,7	70,8	75,2	83,4
Head loss (C50; W7)	(1)	kPa	34	27	18	19	20	23	24
Water flow rate (E-5; W45)	(1)	m³/h	47,2	53,2	60,0	69,2	76,0	80,1	90,0
Head loss (E-5; W45)	(1)	kPa	42	31	21	23	23	26	28
Noise levels									
Sound power level basic unit	(4)	dB(A)	88	89	90	90	91	91	91
Sound pressure level basic unit	(5)	dB(A)	71	72	72	73	73	73	73
Sound power level LN version	(4)	dB(A)	81	82	83	83	84	84	84
Sound pressure level LN version	(5)	dB(A)	64	65	65	66	66	66	66
Dimensions and weights**									
Length		mm	2.834	2.834	2.834	2.834	2.834	3.334	3.334
Depth		mm	872	872	872	872	872	872	872
Height		mm	1.880	1.880	1.880	1.880	1.880	1.880	1.880
Diameters of refrigerant connections									
Suction line diameter		mm	54	67	67	67	67	67	67
Liquid line diameter		mm	35	35	35	35	42	35	35

(1) Condensing temperature 50°C; user-side heat exchanger inlet-outlet water temperature 12/7°C. Values compliant with standard EN 14511

(2) Evaporating temperature -5°C; user-side heat exchanger inlet-outlet water temperature 40/45°C. Values compliant with standard EN 14511

(4) Sound power level obtained from measurements carried out in accordance with standard ISO 3744. Reference conditions: source side heat exchanger inlet/outlet water temperature 30/35°C; user side heat exchanger inlet/outlet water temperature 12/7°C

(5) Sound pressure level measured at a distance of 1 metre from the unit in free field, with directivity factor Q=2. Reference conditions: source side heat exchanger inlet/outlet water temperature 30/35°C; user side heat exchanger inlet/outlet water temperature 12/7°C

(6) The weight refers to the unit without any accessory. The introduction of some accessories such as hydraulic modules or recovery exchangers can lead to increased weight that can exceed 10%. For further details refer to the specific drawing of the selected configuration.

(8) Approximate value. The minimum capacity reached by the unit depends on the operating conditions. The value shown may not be suitable for calculating the minimum volume of water: to do this, consult the "Minimum water content in the system" section.

** Basic CH unit without included accessories

TETRIS W REV LC/HP

		3.2	4.2	5.2	6.2	7.2	8.2	9.2	10.2	
Cooling (C50; W7)										
Refrigeration capacity	(1)	kW	30,4	35,1	37,1	44,5	51,5	59,4	67,0	78,4
Total absorbed power	(1)	kW	10,2	11,7	12,5	14,3	16,9	18,9	21,0	25,0
EER	(1)		2,97	2,99	2,97	3,11	3,05	3,15	3,20	3,14
Heating (E-5; W45)										
Heating capacity	(2)	kW	34,3	39,2	41,8	47,9	56,7	64,6	71,8	85,2
Total absorbed power	(2)	kW	9,7	11,1	11,8	13,6	16,0	18,2	20,0	23,6
COP	(2)		3,54	3,55	3,56	3,51	3,53	3,55	3,59	3,62
Compressors										
Compressors/Circuits		n°/n°	2/1	2/1	2/1	2/1	2/1	2/1	2/1	2/1
Minimum capacity reduction step	(8)	%	50%	50%	50%	50%	50%	50%	50%	50%
User-side heat exchanger										
Quantity		n°	1	1	1	1	1	1	1	1
Water flow rate (C50; W7)	(1)	m³/h	5,3	6,1	6,4	7,7	8,9	10,3	11,6	13,5
Head loss (C50; W7)	(1)	kPa	33	28	30	26	34	25	29	29
Water flow rate (E-5; W45)	(1)	m³/h	5,9	6,7	7,2	8,2	9,7	11,1	12,3	14,6
Head loss (E-5; W45)	(1)	kPa	41	34	37	29	40	29	32	33
Noise levels										
Sound power level of basic unit	(5)	dB(A)	73	75	75	77	77	78	79	80
Sound pressure level of basic unit	(4)	dB(A)	57	59	60	62	62	63	63	65
Sound power level of LN version	(5)	dB(A)	66	68	68	70	70	71	72	73
Sound pressure level of LN version	(4)	dB(A)	50	52	53	55	55	56	56	58
Unit dimensions and weights **										
Length		mm	1.633	1.633	1.633	1.633	1.633	1.633	1.633	1.633
Depth		mm	792	792	792	792	792	792	792	792
Height		mm	967	967	967	1.880	1.880	1.880	1.880	1.880
Diameters of refrigerant connections										
Suction line diameter		mm	28	35	35	42	42	42	42	42
Liquid line diameter		mm	16	18	18	22	22	28	28	28

(1) Condensing temperature 50°C; user-side heat exchanger inlet-outlet water temperature 12/7°C. Values compliant with standard EN 14511

(2) Evaporating temperature -5°C; user-side heat exchanger inlet-outlet water temperature 40/45°C. Values compliant with standard EN 14511

(4) Unit operating at nominal operating capacity, without any accessories, with source-side heat exchanger inlet-outlet water temperature 30-35°C and user-side heat exchanger inlet-outlet water temperature 12-7°C. Binding values. Values obtained from measures taken according to standard ISO 3744 and to the Eurovent certification programme where applicable.

(5) Values obtained from the sound power level (condition in note 4), referred to a distance of 1 m from the unit in free field with directivity factor Q = 2. Non-binding values.

(8) Approximate value. The minimum capacity reached by the unit depends on the operating conditions. The value shown may not be suitable for calculating the minimum volume of water: to do this, consult the "Minimum water content in the system" section.

** Basic CH unit without included accessories

TETRIS W REV LC/HP

			12.2	13.2	15.2	17.2	19.2	20.2	24.2	27.2
Cooling (C50; W7)										
Refrigeration capacity	(1)	kW	89,1	100,2	113,5	126,4	145,1	163,3	180,4	214,5
Total absorbed power	(1)	kW	28,6	32,0	36,3	40,5	46,0	51,7	60,1	66,0
EER	(1)		3,12	3,13	3,13	3,12	3,15	3,16	3,00	3,25
Heating (E-5; W45)										
Heating capacity	(2)	kW	96,5	108,1	122,8	137,4	157,0	176,4	198,5	221,6
Total absorbed power	(2)	kW	27,1	30,4	34,7	38,8	44,2	49,9	56,3	62,5
COP	(2)		3,56	3,55	3,54	3,54	3,55	3,53	3,53	3,55
Compressors										
Compressors/Circuits		n°/n°	2/1	2/1	2/1	2/1	2/1	2/1	2/1	2/1
Minimum capacity reduction step	(8)	%	43%	50%	44%	50%	45%	50%	50%	50%
User-side heat exchanger										
Quantity		n°	1	1	1	1	1	1	1	1
Water flow rate (C50; W7)	(1)	m³/h	15,4	17,3	19,6	21,8	25,1	28,2	31,1	37,0
Head loss (C50; W7)	(1)	kPa	37	31	33	34	33	42	24	23
Water flow rate (E-5; W45)	(1)	m³/h	16,5	18,5	21,0	23,5	26,9	30,2	34,0	38,0
Head loss (E-5; W45)	(1)	kPa	42	35	38	40	39	48	29	24
Noise levels										
Sound power level of basic unit	(5)	dB(A)	83	84	85	85	86	87	87	88
Sound pressure level of basic unit	(4)	dB(A)	66	67	69	69	70	71	71	71
Sound power level of LN version	(5)	dB(A)	76	77	78	78	79	80	80	81
Sound pressure level of LN version	(4)	dB(A)	59	60	62	62	63	64	64	64
Unit dimensions and weights **										
Length		mm	1.633	1.633	1.633	1.633	1.633	1.633	2.017	2.017
Depth		mm	792	792	792	792	792	792	872	872
Height		mm	1.880	1.880	1.880	1.880	1.880	1.880	1.880	1.880
Diameters of refrigerant connections										
Suction line diameter		mm	42	54	54	54	67	67	67	67
Liquid line diameter		mm	28	35	35	35	35	35	35	35

(1) Condensing temperature 50°C; user-side heat exchanger inlet-outlet water temperature 12/7°C. Values compliant with standard EN 14511

(2) Evaporating temperature -5°C; user-side heat exchanger inlet-outlet water temperature 40/45°C. Values compliant with standard EN 14511

(4) Unit operating at nominal operating capacity, without any accessories, with source-side heat exchanger inlet-outlet water temperature 30-35°C and user-side heat exchanger inlet-outlet water temperature 12-7°C. Binding values. Values obtained from measures taken according to standard ISO 3744 and to the Eurovent certification programme where applicable.

(5) Values obtained from the sound power level (condition in note 4), referred to a distance of 1 m from the unit in free field with directivity factor Q = 2. Non-binding values.

(8) Approximate value. The minimum capacity reached by the unit depends on the operating conditions. The value shown may not be suitable for calculating the minimum volume of water: to do this, consult the "Minimum water content in the system" section.

** Basic CH unit without included accessories

TETRIS W REV LC/HP

			30.3	34.3	40.3	18.4	20.4	24.4	26.4	30.4
Cooling (C50; W7)										
Refrigeration capacity	(1)	kW	248,4	270,9	302,8	134,3	158,2	178,8	201,0	232,9
Total absorbed power	(1)	kW	77,3	90,0	98,9	41,7	49,6	56,7	63,7	72,1
EER	(1)		3,21	3,01	3,06	3,22	3,19	3,16	3,15	3,23
Heating (E-5; W45)										
Heating capacity	(2)	kW	262,5	299,1	333,0	144,5	169,6	193,2	210,1	243,2
Total absorbed power	(2)	kW	73,1	85,5	93,2	40,2	47,4	54,1	66,1	67,7
COP	(2)		3,59	3,50	3,57	3,59	3,58	3,57	3,18	3,59
Compressors										
Compressors/Circuits		n°/n°	3/1	3/1	3/1	4/2	4/2	4/2	4/2	4/2
Minimum capacity reduction step	(8)	%	67%	67%	67%	25%	25%	21%	25%	22%
User-side heat exchanger										
Quantity		n°	1	1	1	1	1	1	1	1
Water flow rate (C50; W7)	(1)	m³/h	42,9	46,7	52,2	23,2	27,3	30,9	34,7	40,2
Head loss (C50; W7)	(1)	kPa	30	26	30	24	23	24	25	24
Water flow rate (E-5; W45)	(1)	m³/h	45,0	51,3	57,1	24,8	29,1	33,1	36,0	41,7
Head loss (E-5; W45)	(1)	kPa	33	31	36	27	26	28	27	26
Noise levels										
Sound power level of basic unit	(5)	dB(A)	88	88	90	82	83	86	87	88
Sound pressure level of basic unit	(4)	dB(A)	71	71	73	65	66	69	69	71
Sound power level of LN version	(5)	dB(A)	81	81	83	75	76	79	80	81
Sound pressure level of LN version	(4)	dB(A)	64	64	66	58	59	62	62	64
Unit dimensions and weights **										
Length		mm	2.017	2.017	2.017	2.017	2.017	2.834	2.834	2.834
Depth		mm	872	872	872	872	872	872	872	872
Height		mm	1.880	1.880	1.880	1.880	1.880	1.880	1.880	1.880
Diameters of refrigerant connections										
Suction line diameter		mm	67	76	76	42	42	42	54	54
Liquid line diameter		mm	42	42	42	28	28	28	35	35

(1) Condensing temperature 50°C; user-side heat exchanger inlet-outlet water temperature 12/7°C. Values compliant with standard EN 14511

(2) Evaporating temperature -5°C; user-side heat exchanger inlet-outlet water temperature 40/45°C. Values compliant with standard EN 14511

(4) Unit operating at nominal operating capacity, without any accessories, with source-side heat exchanger inlet-outlet water temperature 30-35°C and user-side heat exchanger inlet-outlet water temperature 12-7°C. Binding values. Values obtained from measures taken according to standard ISO 3744 and to the Eurovent certification programme where applicable.

(5) Values obtained from the sound power level (condition in note 4), referred to a distance of 1 m from the unit in free field with directivity factor Q = 2. Non-binding values.

(8) Approximate value. The minimum capacity reached by the unit depends on the operating conditions. The value shown may not be suitable for calculating the minimum volume of water: to do this, consult the "Minimum water content in the system" section.

** Basic CH unit without included accessories

TETRIS W REV LC/HP

			34.4	38.4	40.4	48.4	54.4	56.6	60.6
Cooling (C50; W7)									
Refrigeration capacity	(1)	kW	246,7	287,3	325,3	363,8	410,7	436,2	483,8
Total absorbed power	(1)	kW	80,6	91,7	102,7	119,8	131,5	137,4	154,0
EER	(1)		3,06	3,13	3,17	3,04	3,12	3,18	3,14
Heating (E-5; W45)									
Heating capacity	(2)	kW	275,6	310,4	349,6	403,1	442,9	466,5	524,7
Total absorbed power	(2)	kW	77,1	87,4	97,2	114,5	124,7	129,2	145,8
COP	(2)		3,58	3,55	3,60	3,52	3,55	3,61	3,60
Compressors									
Compressors/Circuits		n°/n°	4/2	4/2	4/2	4/2	4/2	6/2	6/2
Minimum capacity reduction step	(8)	%	25%	23%	25%	25%	25%	30%	33%
User-side heat exchanger									
Quantity		n°	1	1	1	1	1	1	1
Water flow rate (C50; W7)	(1)	m³/h	42,6	49,5	56,1	62,7	70,8	75,2	83,4
Head loss (C50; W7)	(1)	kPa	34	27	18	19	20	23	24
Water flow rate (E-5; W45)	(1)	m³/h	47,2	53,2	60,0	69,2	76,0	80,1	90,0
Head loss (E-5; W45)	(1)	kPa	42	31	21	23	23	26	28
Noise levels									
Sound power level of basic unit	(5)	dB(A)	88	89	90	90	91	91	91
Sound pressure level of basic unit	(4)	dB(A)	71	72	72	73	73	73	73
Sound power level of LN version	(5)	dB(A)	81	82	83	83	84	84	84
Sound pressure level of LN version	(4)	dB(A)	64	65	65	66	66	66	66
Unit dimensions and weights **									
Length		mm	2.834	2.834	2.834	2.834	2.834	3.334	3.334
Depth		mm	872	872	872	872	872	872	872
Height		mm	1.880	1.880	1.880	1.880	1.880	1.880	1.880
Diameters of refrigerant connections									
Suction line diameter		mm	54	67	67	67	67	67	67
Liquid line diameter		mm	35	35	35	35	42	35	35

(1) Condensing temperature 50°C; user-side heat exchanger inlet-outlet water temperature 12/7°C. Values compliant with standard EN 14511

(2) Evaporating temperature -5°C; user-side heat exchanger inlet-outlet water temperature 40/45°C. Values compliant with standard EN 14511

(4) Unit operating at nominal operating capacity, without any accessories, with source-side heat exchanger inlet-outlet water temperature 30-35°C and user-side heat exchanger inlet-outlet water temperature 12-7°C. Binding values. Values obtained from measures taken according to standard ISO 3744 and to the Eurovent certification programme where applicable.

(5) Values obtained from the sound power level (condition in note 4), referred to a distance of 1 m from the unit in free field with directivity factor Q = 2. Non-binding values.

(8) Approximate value. The minimum capacity reached by the unit depends on the operating conditions. The value shown may not be suitable for calculating the minimum volume of water: to do this, consult the "Minimum water content in the system" section.

** Basic CH unit without included accessories

ECODESIGN

INTRODUCTION

The Ecodesign/ErP Directive (2009/125/EC) lays down new standards for more efficient energy use.

The Directive contains various regulations; as regards chiller products and heat pumps, the regulations of interest are the following:

- Regulation 2013/813, for small heat pumps ($P_{\text{design}} \leq 400$ kW)
- Regulation 2016/2281, for chillers and heat pumps with $P_{\text{design}} > 400$ kW
- Regulation 2013/811, for heat pumps with $P_{\text{design}} \leq 70$ kW.

The last-mentioned regulation (2013/811) regards the labelling (Ecolabel certification) of small heat pumps.

The other two regulations (2013/813 and 2016/2281) set seasonal efficiency targets that the products must comply with to be sold and installed in the European Union (essential requirement for CE marking).

These efficiency limits are defined through ratios, which are respectively:

- η_{sh} (SCOP), with reference to regulation 2013/813
- η_{sc} (SEER) for comfort applications and SEPR for process applications, with reference to regulation 2016/2281.

As regards regulation 2016/2281, with effect from 1st January 2021, the required minimum efficiency limit will be raised (Tier 2) from the current threshold (Tier 1).

The figure below schematically illustrates the correspondence between product and reference energy ratio.

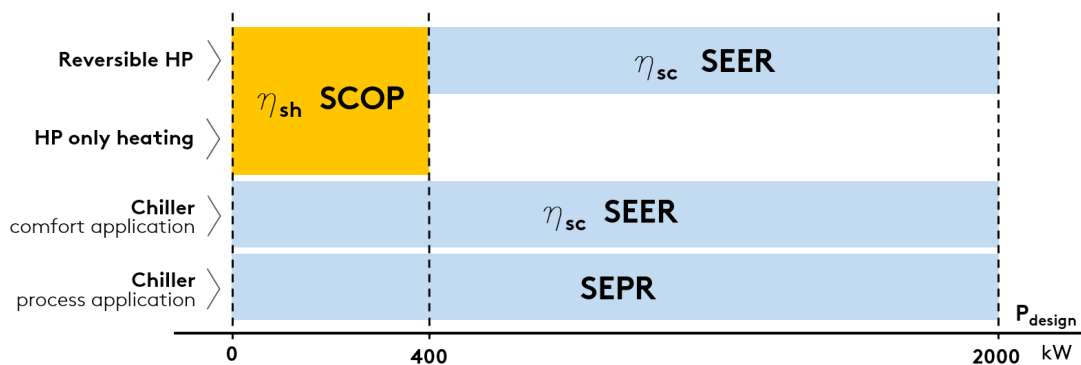

Some notes and clarifications:

For comfort applications, regulation 2016/2281 sets the η_{sc} (SEER) ratio in two different operating conditions:

- SEER calculated with machine inlet/outlet water temperature of 12/7°C (low temperature application),
- SEER calculated with machine inlet/outlet water temperature of 23/18°C (medium temperature application).

The minimum efficiency requirement is the same, but can be met at condition 12/7°C or at condition 23/18°C, depending on the application envisaged for the machine.

Regulation 2013/813 distinguishes two different types: at low temperature and at medium temperature.

The following refer to the application at low temperature: (low temperature application) all heat pumps whose maximum delivery temperature for heating purposes is lower than 52°C with source at temperature of -7°C and -8°C wet bulb (air-water unit) or inlet 10°C (water-water unit), at the reference design conditions for an average climate. For these, the efficiency ratio is "low temperature application" (outlet water temperature 35°C).

For all the other heat pumps, the efficiency ratio is related to "medium temperature application" (outlet water temperature 55°C).

The ratios must be calculated according to the reference European heating season in average climatic conditions.

The minimum efficiency requirements set by the regulations are indicated below.

REGULATION 2016/2281, comfort application

TYPE OF UNIT		MINIMUM REQUIREMENT			
		Tier 1		Tier 2 (2021)	
SOURCE	P _{design}	η _{sc} [%]	SEER	η _{sc} [%]	SEER
air	< 400kW	149	3,8	161	4,1
air	≥ 400kW	161	4,1	179	4,55
water	< 400kW	196	5,1	200	5,2
water	≥ 400kW and < 1500kW	227	5,875	252	6,5
water	≥ 1500kW	245	6,325	272	7

REGULATION 2016/2281, process application

TYPE OF UNIT		MINIMUM REQUIREMENT	
		Tier 1	Tier 2 (2021)
SOURCE	P _{design}	SEPR	SEPR
air	< 400kW	4,5	5
air	≥ 400kW	5	5,5
water	< 400kW	6,5	7
water	≥ 400kW and < 1500kW	7,5	8
water	≥ 1500kW	8	8,5

REGULATION 2013/813

SOURCE	APPLICATION	MINIMUM REQUIREMENT	
		η _{sh} [%]	SCOP
air	low temperature application	125	3,2
water	low temperature application	125	3,325
air	medium temperature application	110	2,825
water	medium temperature application	110	2,95

The conformity of the product must be checked according to the type of application, whether comfort or process, and at the required outlet water temperature.

The two schematic tables below, respectively for comfort application and for process application, indicate the reference of the required conformity according to the type of product and the set point temperature (reference to regulations 2016/2281 and 2013/813).

Important note: for mixed comfort and process applications, the reference application for conformity is the comfort application.

COMFORT APPLICATION

PRODUCT	OUTLET WATER TEMPERATURE	COMPLIANCE INDEX	REGULATION
Chiller	< 18°C	SEER/η _{sc} low temperature application	2016/2283
	≥ 18°C	SEER/η _{sc} medium temperature application	2016/2283
Heat pumps (reversible and only heating) P_{design} ≤ 400kW		SCOP/η _{sh}	2013/815
Reversible heat pumps P_{design} > 400kW	< 18°C	SEER/η _{sc} low temperature application	2016/2283
	≥ 18°C	SEER/η _{sc} medium temperature application	2016/2283
Heat pumps only heating P_{design} > 400kW		-	-

PROCESS APPLICATION

PRODUCT	OUTLET WATER TEMPERATURE	COMPLIANCE INDEX	REGULATION
Chiller	≥ +2°C , ≤ 12°C	SEPR	2016/2283
	> 12°C	-	-
	> -8°C , < +2°C	-	-

- = exemption from Ecodesign

Some specifications and notes follow.

Partly completed machinery

The term partly completed machinery refers to all units without a user-side or source-side heat exchanger, and therefore to all LC, LE, LC/HP and LE/HP versions. Since these are "non-complete" machines, conformity with Ecodesign depends on combination with the remote heat exchanger.

All the partly completed machinery is CE marked and accompanied by a declaration of conformity. Installation in European Union countries is therefore allowed; correct selection and installation of the remote heat exchanger must be ensured, in accordance with the above cases.

EC fans:

The only option that positively affects the performance of the unit, by increasing its seasonal energy efficiency ratio, is the VEC accessory.

A unit equipped with EC fans has a higher SEER (η_{sc}) than the configuration with standard fans.

TETRIS W REV RANGE

As regards, specifically, the Tetris W Rev range, below, the regulations of interest for the various units in the various configurations.

Tetris W Rev:

regulation 2016/2281.

Tetris W Rev HPW:

- up to size 40.3 regulation 2013/813, from size 40.4 regulation 2016/2281

Tetris W Rev /HP:

- up to size 40.4 regulation 2013/813, from size 48.4 regulation 2016/2281

Tetris W Rev /LC and Tetris W Rev LC/NG:

- up to size 48.4 regulation 2013/813, from size 54.4 regulation 2016/2281

Tetris W Rev /OH:

exempt from regulation 813 and 2281.

The tables below give information on the conformity of the units and the seasonal energy performance ratios with regard to the reference regulation.

TETRIS W REV

			3.2	4.2	5.2	6.2	7.2	8.2	9.2	10.2
REGULATION 2016/2281										
Pdesign	(1)	kw	38	44	50	55	64	72	82	100
Compliance 12/7										
Compliance	(1)		Y	Y	Y	Y	Y	Y	Y	Y
η_{sc}	(1)	%	201,2	201,3	200,8	202,6	201,7	205,6	200,9	200
SEER	(1)		5,23	5,23	5,22	5,27	5,24	5,34	5,22	5,2
Compliance Tier 2 (2021)	(1)		N	N	N	N	N	N	N	N
Compliance 12/7 unit with EC fans										
Compliance	(1)		Y	Y	Y	Y	Y	Y	Y	Y
η_{sc}	(1)	%	-	-	-	-	-	-	-	-
SEER	(1)		-	-	-	-	-	-	-	-
Compliance Tier 2 (2021)	(1)		N	N	N	N	N	N	N	N
Compliance 23/18										
Compliance	(2)		Y	Y	Y	Y	Y	Y	Y	Y
η_{sc}	(2)	%	-	-	-	-	-	-	-	-
SEER	(2)		-	-	-	-	-	-	-	-
Compliance SEPR										
Compliance	(3)		Y	Y	Y	Y	Y	Y	Y	Y
SEPR	(3)		7,22	7,2	7,27	7,21	7,28	7,25	7,23	7,22
			12.2	13.2	15.2	17.2	19.2	20.2	24.2	27.2
REGULATION 2016/2281										
Pdesign	(1)	kw	113	131	145	161	183	200	222	252
Compliance 12/7										
Compliance	(1)		Y	Y	Y	Y	Y	Y	Y	Y
η_{sc}	(1)	%	206,3	201,5	201,2	200,5	215,4	205,8	200,7	222,5
SEER	(1)		5,36	5,24	5,23	5,21	5,59	5,35	5,22	5,76
Compliance Tier 2 (2021)	(1)		N	N	N	N	N	N	N	N
Compliance 12/7 unit with EC fans										
Compliance	(1)		Y	Y	Y	Y	Y	Y	Y	Y
η_{sc}	(1)	%	-	-	-	-	-	-	-	-
SEER	(1)		-	-	-	-	-	-	-	-
Compliance Tier 2 (2021)	(1)		N	N	N	N	N	N	N	N
Compliance 23/18										
Compliance	(2)		Y	Y	Y	Y	Y	Y	Y	Y
η_{sc}	(2)	%	-	-	-	-	-	-	-	-
SEER	(2)		-	-	-	-	-	-	-	-
Compliance SEPR										
Compliance	(3)		Y	Y	Y	Y	Y	Y	Y	Y
SEPR	(3)		7,2	7,18	7,16	7,14	7,23	7,12	7,1	7,17

Y = unit in compliance with Ecodesign at the indicated condition.

N = unit not in compliance with Ecodesign at the indicated condition: it can be installed only in non-EU countries.

- = value not necessary: conformity is already provided at the most restrictive condition (1).

- (1) User-side heat exchanger water inlet/outlet temperature 12/7°C (low temperature application), with reference to regulation 2016/2281 and standard EN 14825.
- (2) User-side heat exchanger water inlet/outlet temperature 23/18°C (medium temperature application), with reference to regulation 2016/2281 and standard EN 14825.
- (3) User-side heat exchanger water inlet/outlet temperature 12/7°C, with reference to regulation 2016/2281 and norm EN 14825.

TETRIS W REV

			30.3	34.3	40.3	18.4	20.4	24.4	26.4	30.4
REGULATION 2016/2281										
Pdesign	(1)	kw	311	347	385	163	198	225	254	288
Compliance 12/7										
Compliance	(1)		Y	Y	Y	Y	Y	Y	Y	Y
η_{sc}	(1)	%	215,7	218,5	220,1	213	215,2	216,2	221,3	209,8
SEER	(1)		5,59	5,66	5,7	5,52	5,58	5,6	5,73	5,45
Compliance Tier 2 (2021)	(1)		N	N	N	N	N	N	N	N
Compliance 12/7 unit with EC fans										
Compliance	(1)		Y	Y	Y	Y	Y	Y	Y	Y
η_{sc}	(1)	%	-	-	-	-	-	-	-	-
SEER	(1)		-	-	-	-	-	-	-	-
Compliance Tier 2 (2021)	(1)		N	N	N	N	N	N	N	N
Compliance 23/18										
Compliance	(2)		Y	Y	Y	Y	Y	Y	Y	Y
η_{sc}	(2)	%	-	-	-	-	-	-	-	-
SEER	(2)		-	-	-	-	-	-	-	-
Compliance SEPR										
Compliance	(3)		Y	Y	Y	Y	Y	Y	Y	Y
SEPR	(3)		7,15	7,15	7,25	7,21	7,25	7,37	7,29	7,42

			34.4	38.4	40.4	48.4	54.4	56.6	60.6	
REGULATION 2016/2281										
Pdesign	(1)	kw	320	365	410	455	514	546	617	
Compliance 12/7										
Compliance	(1)		Y	Y	Y	Y	Y	Y	Y	Y
η_{sc}	(1)	%	212,1	216,8	228,4	231,2	229,9	227,4	227,2	
SEER	(1)		5,5	5,62	5,91	5,98	5,95	5,89	5,88	
Compliance Tier 2 (2021)	(1)		N	N	N	N	N	N	N	
Compliance 12/7 unit with EC fans										
Compliance	(1)		Y	Y	Y	Y	Y	Y	Y	Y
η_{sc}	(1)	%	-	-	-	-	-	-	-	-
SEER	(1)		-	-	-	-	-	-	-	-
Compliance Tier 2 (2021)	(1)		N	N	N	N	N	N	N	N
Compliance 23/18										
Compliance	(2)		Y	Y	Y	Y	Y	Y	Y	Y
η_{sc}	(2)	%	-	-	-	-	-	-	-	-
SEER	(2)		-	-	-	-	-	-	-	-
Compliance SEPR										
Compliance	(3)		Y	Y	Y	Y	Y	Y	Y	Y
SEPR	(3)		7,43	7,5	7,5	7,51	7,53	7,52	7,51	

Y = unit in compliance with Ecodesign at the indicated condition.

N = unit not in compliance with Ecodesign at the indicated condition: it can be installed only in non-EU countries.

- = value not necessary: conformity is already provided at the most restrictive condition (1).

(1) User-side heat exchanger water inlet/outlet temperature 12/7°C (low temperature application), with reference to regulation 2016/2281 and standard EN 14825.

(2) User-side heat exchanger water inlet/outlet temperature 23/18°C (medium temperature application), with reference to regulation 2016/2281 and standard EN 14825.

(3) User-side heat exchanger water inlet/outlet temperature 12/7°C, with reference to regulation 2016/2281 and norm EN 14825.

TETRIS W REV /HP

			3.2	4.2	5.2	6.2	7.2	8.2	9.2	10.2
REGULATION 2016/2281										
Pdesign	(1)	kw	35	40	43	51	60	69	77	89
Compliance 12/7										
Compliance	(1)		N	N	N	N	N	N	N	N
η_{sc}	(1)	%	-	-	-	-	-	-	-	-
SEER	(1)		-	-	-	-	-	-	-	-
Compliance Tier 2 (2021)	(1)		N	N	N	N	N	N	N	N
Compliance 12/7 unit with EC fans										
Compliance	(1)		N	N	N	N	N	N	N	N
η_{sc}	(1)	%	-	-	-	-	-	-	-	-
SEER	(1)		-	-	-	-	-	-	-	-
Compliance Tier 2 (2021)	(1)		N	N	N	N	N	N	N	N
Compliance 23/18										
Compliance	(2)		N	N	N	N	N	N	N	N
η_{sc}	(2)	%	-	-	-	-	-	-	-	-
SEER	(2)		-	-	-	-	-	-	-	-
Compliance SEPR										
Compliance	(3)		N	N	N	N	N	N	N	N
SEPR	(3)		-	-	-	-	-	-	-	-
			12.2	13.2	15.2	17.2	19.2	20.2	24.2	27.2
REGULATION 2016/2281										
Pdesign	(1)	kw	102	115	129	144	165	186	206	237
Compliance 12/7										
Compliance	(1)		N	N	N	N	N	N	N	N
η_{sc}	(1)	%	-	-	-	-	-	-	-	-
SEER	(1)		-	-	-	-	-	-	-	-
Compliance Tier 2 (2021)	(1)		N	N	N	N	N	N	N	N
Compliance 12/7 unit with EC fans										
Compliance	(1)		N	N	N	N	N	N	N	N
η_{sc}	(1)	%	-	-	-	-	-	-	-	-
SEER	(1)		-	-	-	-	-	-	-	-
Compliance Tier 2 (2021)	(1)		N	N	N	N	N	N	N	N
Compliance 23/18										
Compliance	(2)		N	N	N	N	N	N	N	N
η_{sc}	(2)	%	-	-	-	-	-	-	-	-
SEER	(2)		-	-	-	-	-	-	-	-
Compliance SEPR										
Compliance	(3)		N	N	N	N	N	N	N	N
SEPR	(3)		-	-	-	-	-	-	-	-

Y = unit in compliance with Ecodesign at the indicated condition.

N = unit not in compliance with Ecodesign at the indicated condition: it can be installed only in non-EU countries.

- = value not necessary: conformity is already provided at the most restrictive condition (1).

- (1) User-side heat exchanger water inlet/outlet temperature 12/7°C (low temperature application), with reference to regulation 2016/2281 and standard EN 14825.
- (2) User-side heat exchanger water inlet/outlet temperature 23/18°C (medium temperature application), with reference to regulation 2016/2281 and standard EN 14825.
- (3) User-side heat exchanger water inlet/outlet temperature 12/7°C, with reference to regulation 2016/2281 and norm EN 14825.

TETRIS W REV /HP

			30.3	34.3	40.3	18.4	20.4	24.4	26.4	30.4
REGULATION 2016/2281										
Pdesign	(1)	kW	284	312	350	152	180	205	231	269
Compliance 12/7										
Compliance	(1)		N	N	N	N	N	N	N	N
η_{sc}	(1)	%	-	-	-	-	-	-	-	-
SEER	(1)		-	-	-	-	-	-	-	-
Compliance Tier 2 (2021)	(1)		N	N	N	N	N	N	N	N
Compliance 12/7 unit with EC fans										
Compliance	(1)		N	N	N	N	N	N	N	N
η_{sc}	(1)	%	-	-	-	-	-	-	-	-
SEER	(1)		-	-	-	-	-	-	-	-
Compliance Tier 2 (2021)	(1)		N	N	N	N	N	N	N	N
Compliance 23/18										
Compliance	(2)		N	N	N	N	N	N	N	N
η_{sc}	(2)	%	-	-	-	-	-	-	-	-
SEER	(2)		-	-	-	-	-	-	-	-
Compliance SEPR										
Compliance	(3)		N	N	N	N	N	N	N	N
SEPR	(3)		-	-	-	-	-	-	-	-

			34.4	38.4	40.4	48.4	54.4	56.6	60.6	
REGULATION 2016/2281										
Pdesign	(1)	kW	281	329	366	411	467	493	549	
Compliance 12/7										
Compliance	(1)		Y	Y	Y	Y	Y	Y	Y	Y
η_{sc}	(1)	%	-	-	-	227,3	227,2	227,2	227,2	
SEER	(1)		-	-	-	5,88	5,88	5,88	5,88	
Compliance Tier 2 (2021)	(1)		N	N	N	N	N	N	N	
Compliance 12/7 unit with EC fans										
Compliance	(1)		N	N	N	N	N	N	N	
η_{sc}	(1)	%	-	-	-	-	-	-	-	
SEER	(1)		-	-	-	-	-	-	-	
Compliance Tier 2 (2021)	(1)		N	N	N	N	N	N	N	
Compliance 23/18										
Compliance	(2)		Y	Y	Y	Y	Y	Y	Y	
η_{sc}	(2)	%	-	-	-	-	-	-	-	
SEER	(2)		-	-	-	-	-	-	-	
Compliance SEPR										
Compliance	(3)		N	N	N	N	N	N	N	
SEPR	(3)		-	-	-	-	-	-	-	

Y = unit in compliance with Ecodesign at the indicated condition.

N = unit not in compliance with Ecodesign at the indicated condition: it can be installed only in non-EU countries.

- = value not necessary: conformity is already provided at the most restrictive condition (1).

(1) User-side heat exchanger water inlet/outlet temperature 12/7°C (low temperature application), with reference to regulation 2016/2281 and standard EN 14825.

(2) User-side heat exchanger water inlet/outlet temperature 23/18°C (medium temperature application), with reference to regulation 2016/2281 and standard EN 14825.

(3) User-side heat exchanger water inlet/outlet temperature 12/7°C, with reference to regulation 2016/2281 and norm EN 14825.

TETRIS W REV /HP

			3.2	4.2	5.2	6.2	7.2	8.2	9.2	10.2
REGULATION 2013/813										
Pdesign	(1)	kW	42	48	52	60	69	78	89	107
Compliance MT										
Compliance	(1)		Y	Y	Y	Y	Y	Y	Y	Y
η_{sc}	(1)	%	169,9	169,9	175,8	180,6	182,3	178,6	177,9	177,3
SCOP	(1)		4,45	4,45	4,59	4,72	4,76	4,67	4,65	4,63
Compliance LT										
Compliance	(2)		Y	Y	Y	Y	Y	Y	Y	Y
η_{sc}	(2)	%	204	202,4	204,8	211,2	208,4	223,6	213,6	214
SCOP	(2)		5,3	5,26	5,32	5,48	5,41	5,79	5,54	5,55
REGULATION 2013/811										
Ecolabel	(3)		A++	A++	A++	A++	A++	A++	-	-
			12.2	13.2	15.2	17.2	19.2	20.2	24.2	27.2
REGULATION 2013/813										
Pdesign	(1)	kW	121	136	155	172	196	215	241	270
Compliance MT										
Compliance	(1)		Y	Y	Y	Y	Y	Y	Y	Y
η_{sc}	(1)	%	181,5	178,9	182,7	176,5	183,3	178,9	178,2	182,7
SCOP	(1)		4,73	4,67	4,77	4,61	4,78	4,67	4,65	4,77
Compliance LT										
Compliance	(2)		Y	Y	Y	Y	Y	Y	Y	Y
η_{sc}	(2)	%	210,4	214	212	212,8	216,4	211,2	217,2	227,2
SCOP	(2)		5,46	5,55	5,5	5,52	5,61	5,48	5,63	5,88
REGULATION 2013/811										
Ecolabel	(3)		-	-	-	-	-	-	-	-
			30.3	34.3	40.3	18.4	20.4	24.4	26.4	30.4
REGULATION 2013/813										
Pdesign	(1)	kW	337	384	427	175	212	241	271	308
Compliance MT										
Compliance	(1)		Y	Y	N	Y	Y	Y	Y	Y
η_{sc}	(1)	%	189,5	181	-	188,3	190,7	180,1	191,1	182,6
SCOP	(1)		4,94	4,73	-	4,91	4,97	4,7	4,98	4,77
Compliance LT										
Compliance	(2)		Y	Y	N	Y	Y	Y	Y	Y
η_{sc}	(2)	%	213,6	215,6	-	220,8	214	206,8	221,6	216
SCOP	(2)		5,54	5,48	-	5,72	5,55	5,37	5,74	5,6
REGULATION 2013/811										
Ecolabel	(3)		-	-	-	-	-	-	-	-
			34.4	38.4	40.4	48.4	54.4	56.6	60.6	
REGULATION 2013/813										
Pdesign	(1)	kW	345	392	441	494	552	589	663	
Compliance MT										
Compliance	(1)		N	N	N	N	N	N	N	N
η_{sc}	(1)	%	-	-	-	-	-	-	-	-
SCOP	(1)		-	-	-	-	-	-	-	-
Compliance LT										
Compliance	(2)		Y	N	N	N	N	N	N	N
η_{sc}	(2)	%	215,6	-	-	-	-	-	-	-
SCOP	(2)		5,59	-	-	-	-	-	-	-
REGULATION 2013/811										
Ecolabel	(3)		-	-	-	-	-	-	-	-

Y = unit in compliance with Ecodesign at the indicated condition.

- (1) User-side heat exchanger water inlet/outlet temperature 47/55°C, Average climate profile, with reference to regulation 2013/813 and norm EN 14825.
- (2) User-side heat exchanger water inlet/outlet temperature 30/35, Average climate profile, with reference to regulation 2013/813 and norm EN 14825.
- (3) Energy efficiency class with reference to regulation 2013/811, note 4 conditions (low temperature applications).

TETRIS W REV /HPW

			3.2	4.2	5.2	6.2	7.2	8.2	9.2	10.2
REGULATION 2016/2281										
Pdesign	(1)	kW	38	44	50	55	64	72	82	100
Compliance 12/7										
Compliance	(1)		N	N	N	N	N	N	N	N
η_{sc}	(1)	%	154,9	158	160,2	167,4	167,9	178,4	172,6	173,4
SEER	(1)		4,07	4,15	4,2	4,38	4,4	4,66	4,51	4,54
Compliance Tier 2 (2021)	(1)		N	N	N	N	N	N	N	N
Compliance 12/7 unit with EC fans										
Compliance	(1)		N	N	N	N	N	N	N	N
η_{sc}	(1)	%	-	-	-	-	-	-	-	-
SEER	(1)		-	-	-	-	-	-	-	-
Compliance Tier 2 (2021)	(1)		N	N	N	N	N	N	N	N
Compliance 23/18										
Compliance	(2)		N	N	N	N	N	N	N	N
η_{sc}	(2)	%	-	-	-	-	-	-	-	-
SEER	(2)		-	-	-	-	-	-	-	-
Compliance SEPR										
Compliance	(3)		N	N	N	N	N	N	N	N
SEPR	(3)		-	-	-	-	-	-	-	-

			12.2	13.2	15.2	17.2	19.2	20.2	24.2	27.2
REGULATION 2016/2281										
Pdesign	(1)	kW	113	131	145	161	183	200	222	252
Compliance 12/7										
Compliance	(1)		N	N	N	N	N	N	N	N
η_{sc}	(1)	%	175,4	175,6	178,3	174,7	187	182,2	178,5	185,6
SEER	(1)		4,58	4,59	4,66	4,57	4,88	4,75	4,66	4,84
Compliance Tier 2 (2021)	(1)		N	N	N	N	N	N	N	N
Compliance 12/7 unit with EC fans										
Compliance	(1)		N	N	N	N	N	N	N	N
η_{sc}	(1)	%	-	-	-	-	-	-	-	-
SEER	(1)		-	-	-	-	-	-	-	-
Compliance Tier 2 (2021)	(1)		N	N	N	N	N	N	N	N
Compliance 23/18										
Compliance	(2)		N	N	N	N	N	N	N	N
η_{sc}	(2)	%	-	-	-	-	-	-	-	-
SEER	(2)		-	-	-	-	-	-	-	-
Compliance SEPR										
Compliance	(3)		N	N	N	N	N	N	N	N
SEPR	(3)		-	-	-	-	-	-	-	-

Y = unit in compliance with Ecodesign at the indicated condition.

N = unit not in compliance with Ecodesign at the indicated condition: it can be installed only in non-EU countries.

- = value not necessary: conformity is already provided at the most restrictive condition (1).

(1) User-side heat exchanger water inlet/outlet temperature 12/7°C (low temperature application), with reference to regulation 2016/2281 and standard EN 14825.

(2) User-side heat exchanger water inlet/outlet temperature 23/18°C (medium temperature application), with reference to regulation 2016/2281 and standard EN 14825.

(3) User-side heat exchanger water inlet/outlet temperature 12/7°C, with reference to regulation 2016/2281 and norm EN 14825.

TETRIS W REV /HPW

			30.3	34.3	40.3	18.4	20.4	24.4	26.4	30.4
REGULATION 2016/2281										
Pdesign	(1)	kw	311	347	385	163	198	225	254	288
Compliance 12/7										
Compliance	(1)		N	N	N	N	N	N	N	N
η_{sc}	(1)	%	183,8	182,4	190,3	191,9	189,7	187,7	188,3	183,7
SEER	(1)		4,8	4,76	4,96	5	4,94	4,89	4,91	4,79
Compliance Tier 2 (2021)	(1)		N	N	N	N	N	N	N	N
Compliance 12/7 unit with EC fans										
Compliance	(1)		N	N	N	N	N	N	N	N
η_{sc}	(1)	%	-	-	-	-	-	-	-	-
SEER	(1)		-	-	-	-	-	-	-	-
Compliance Tier 2 (2021)	(1)		N	N	N	N	N	N	N	N
Compliance 23/18										
Compliance	(2)		N	N	N	N	N	N	N	N
η_{sc}	(2)	%	-	-	-	-	-	-	-	-
SEER	(2)		-	-	-	-	-	-	-	-
Compliance SEPR										
Compliance	(3)		N	N	N	N	N	N	N	N
SEPR	(3)		-	-	-	-	-	-	-	-

			34.4	38.4	40.4	48.4	54.4	56.6	60.6	
REGULATION 2016/2281										
Pdesign	(1)	kw	320	365	410	455	514	546	617	
Compliance 12/7										
Compliance	(1)		Y	Y	Y	Y	Y	Y	Y	Y
η_{sc}	(1)	%	196,2	198,6	202,3	227,3	227,2	227,2	227,2	227,2
SEER	(1)		5,1	5,17	5,26	5,88	5,88	5,88	5,88	5,88
Compliance Tier 2 (2021)	(1)		N	N	N	N	N	N	N	N
Compliance 12/7 unit with EC fans										
Compliance	(1)		N	N	N	N	N	N	N	N
η_{sc}	(1)	%	-	-	-	-	-	-	-	-
SEER	(1)		-	-	-	-	-	-	-	-
Compliance Tier 2 (2021)	(1)		N	N	N	N	N	N	N	N
Compliance 23/18										
Compliance	(2)		N	N	N	N	N	N	N	N
η_{sc}	(2)	%	-	-	-	-	-	-	-	-
SEER	(2)		-	-	-	-	-	-	-	-
Compliance SEPR										
Compliance	(3)		N	N	N	N	N	N	N	N
SEPR	(3)		-	-	-	-	-	-	-	-

Y = unit in compliance with Ecodesign at the indicated condition.

N = unit not in compliance with Ecodesign at the indicated condition: it can be installed only in non-EU countries.

- = value not necessary: conformity is already provided at the most restrictive condition (1).

(1) User-side heat exchanger water inlet/outlet temperature 12/7°C (low temperature application), with reference to regulation 2016/2281 and standard EN 14825.

(2) User-side heat exchanger water inlet/outlet temperature 23/18°C (medium temperature application), with reference to regulation 2016/2281 and standard EN 14825.

(3) User-side heat exchanger water inlet/outlet temperature 12/7°C, with reference to regulation 2016/2281 and norm EN 14825.

TETRIS W REV HPW

			3.2	4.2	5.2	6.2	7.2	8.2	9.2	10.2
REGULATION 2013/813										
Pdesign	(1)	kW	42	48	52	60	69	78	89	107
Compliance MT										
Compliance	(1)		Y	Y	Y	Y	Y	Y	Y	Y
η_{sc}	(1)	%	169,9	169,9	175,8	180,6	182,3	178,6	177,9	177,3
SCOP	(1)		4,45	4,45	4,59	4,72	4,76	4,67	4,65	4,63
Compliance LT										
Compliance	(2)		Y	Y	Y	Y	Y	Y	Y	Y
η_{sc}	(2)	%	204	202,4	204,8	211,2	208,4	223,6	213,6	214
SCOP	(2)		5,3	5,26	5,32	5,48	5,41	5,79	5,54	5,55
REGULATION 2013/811										
Ecolabel	(3)		A++	A++	A++	A++	A++	A++	-	-
			12.2	13.2	15.2	17.2	19.2	20.2	24.2	27.2
REGULATION 2013/813										
Pdesign	(1)	kW	121	136	155	172	196	215	241	270
Compliance MT										
Compliance	(1)		Y	Y	Y	Y	Y	Y	Y	Y
η_{sc}	(1)	%	181,5	178,9	182,7	176,5	183,3	178,9	178,2	182,7
SCOP	(1)		4,73	4,67	4,77	4,61	4,78	4,67	4,65	4,77
Compliance LT										
Compliance	(2)		Y	Y	Y	Y	Y	Y	Y	Y
η_{sc}	(2)	%	210,4	214	212	212,8	216,4	211,2	217,2	227,2
SCOP	(2)		5,46	5,55	5,5	5,52	5,61	5,48	5,63	5,88
REGULATION 2013/811										
Ecolabel	(3)		-	-	-	-	-	-	-	-
			30.3	34.3	40.3	18.4	20.4	24.4	26.4	30.4
REGULATION 2013/813										
Pdesign	(1)	kW	337	384	427	175	212	241	271	308
Compliance MT										
Compliance	(1)		Y	Y	N	Y	Y	Y	Y	Y
η_{sc}	(1)	%	189,5	181	-	188,3	190,7	180,1	191,1	182,6
SCOP	(1)		4,94	4,73	-	4,91	4,97	4,7	4,98	4,77
Compliance LT										
Compliance	(2)		Y	Y	N	Y	Y	Y	Y	Y
η_{sc}	(2)	%	213,6	215,6	-	220,8	214	206,8	221,6	216
SCOP	(2)		5,54	5,48	-	5,72	5,55	5,37	5,74	5,6
REGULATION 2013/811										
Ecolabel	(3)		-	-	-	-	-	-	-	-
			34.4	38.4	40.4	48.4	54.4	56.6	60.6	
REGULATION 2013/813										
Pdesign	(1)	kW	345	392	441	494	552	589	663	
Compliance MT										
Compliance	(1)		N	N	N	N	N	N	N	N
η_{sc}	(1)	%	-	-	-	-	-	-	-	-
SCOP	(1)		-	-	-	-	-	-	-	-
Compliance LT										
Compliance	(2)		Y	N	N	N	N	N	N	N
η_{sc}	(2)	%	215,6	-	-	-	-	-	-	-
SCOP	(2)		5,59	-	-	-	-	-	-	-
REGULATION 2013/811										
Ecolabel	(3)		-	-	-	-	-	-	-	-

Y = unit in compliance with Ecodesign at the indicated condition.

- (1) User-side heat exchanger water inlet/outlet temperature 47/55°C, Average climate profile, with reference to regulation 2013/813 and norm EN 14825.
- (2) User-side heat exchanger water inlet/outlet temperature 30/35, Average climate profile, with reference to regulation 2013/813 and norm EN 14825.
- (3) Energy efficiency class with reference to regulation 2013/811, note 4 conditions (low temperature applications).

TETRIS W REV OH

			3.2	4.2	5.2	6.2	7.2	8.2	9.2	10.2
REGULATION 2013/813										
Pdesign	(1)	kW	42	48	52	60	69	78	89	107
Compliance MT										
Compliance	(1)		Y	Y	Y	Y	Y	Y	Y	Y
η_{sc}	(1)	%	169,9	169,9	175,8	180,6	182,3	178,6	177,9	177,3
SCOP	(1)		4,45	4,45	4,59	4,72	4,76	4,67	4,65	4,63
Compliance LT										
Compliance	(2)		Y	Y	Y	Y	Y	Y	Y	Y
η_{sc}	(2)	%	204	202,4	204,8	211,2	208,4	223,6	213,6	214
SCOP	(2)		5,3	5,26	5,32	5,48	5,41	5,79	5,54	5,55
REGULATION 2013/811										
Ecolabel	(3)		A++	A++	A++	A++	A++	A++	-	-
			12.2	13.2	15.2	17.2	19.2	20.2	24.2	27.2
REGULATION 2013/813										
Pdesign	(1)	kW	121	136	155	172	196	215	241	270
Compliance MT										
Compliance	(1)		Y	Y	Y	Y	Y	Y	Y	Y
η_{sc}	(1)	%	181,5	178,9	182,7	176,5	183,3	178,9	178,2	182,7
SCOP	(1)		4,73	4,67	4,77	4,61	4,78	4,67	4,65	4,77
Compliance LT										
Compliance	(2)		Y	Y	Y	Y	Y	Y	Y	Y
η_{sc}	(2)	%	210,4	214	212	212,8	216,4	211,2	217,2	227,2
SCOP	(2)		5,46	5,55	5,5	5,52	5,61	5,48	5,63	5,88
REGULATION 2013/811										
Ecolabel	(3)		-	-	-	-	-	-	-	-
			30.3	34.3	40.3	18.4	20.4	24.4	26.4	30.4
REGULATION 2013/813										
Pdesign	(1)	kW	337	384	427	175	212	241	271	308
Compliance MT										
Compliance	(1)		Y	Y	N	Y	Y	Y	Y	Y
η_{sc}	(1)	%	189,5	181	-	188,3	190,7	180,1	191,1	182,6
SCOP	(1)		4,94	4,73	-	4,91	4,97	4,7	4,98	4,77
Compliance LT										
Compliance	(2)		Y	Y	N	Y	Y	Y	Y	Y
η_{sc}	(2)	%	213,6	215,6	-	220,8	214	206,8	221,6	216
SCOP	(2)		5,54	5,48	-	5,72	5,55	5,37	5,74	5,6
REGULATION 2013/811										
Ecolabel	(3)		-	-	-	-	-	-	-	-
			34.4	38.4	40.4	48.4	54.4	56.6	60.6	
REGULATION 2013/813										
Pdesign	(1)	kW	345	392	441	494	552	589	663	
Compliance MT										
Compliance	(1)		N	N	N	N	N	N	N	N
η_{sc}	(1)	%	-	-	-	-	-	-	-	-
SCOP	(1)		-	-	-	-	-	-	-	-
Compliance LT										
Compliance	(2)		Y	N	N	N	N	N	N	N
η_{sc}	(2)	%	215,6	-	-	-	-	-	-	-
SCOP	(2)		5,59	-	-	-	-	-	-	-
REGULATION 2013/811										
Ecolabel	(3)		-	-	-	-	-	-	-	-

Y = unit in compliance with Ecodesign at the indicated condition.

- (1) User-side heat exchanger water inlet/outlet temperature 47/55°C, Average climate profile, with reference to regulation 2013/813 and norm EN 14825.
- (2) User-side heat exchanger water inlet/outlet temperature 30/35, Average climate profile, with reference to regulation 2013/813 and norm EN 14825.
- (3) Energy efficiency class with reference to regulation 2013/811, note 4 conditions (low temperature applications).

ELECTRICAL SPECIFICATIONS

			3.2	4.2	5.2	6.2	7.2	8.2	9.2	10.2
General electrical specifications										
Max. absorbed power (FLI)	(1)	kW	14	17	18	20	24	26	31	37
Max. absorbed current (FLA)	(1)	A	24	29	29	35	41	46	51	61
Rated current (Inom)	(2)	A	22	33	32	38	40	43	51	52
cosφ standard unit	(2)		0,80	0,80	0,80	0,83	0,83	0,83	0,78	0,75
Nominal current with power factor correction (Inom)	(2)	A	18	28	27	34	35	37	42	41
cosφ unit with power factor correction	(2)		0,98	0,95	0,95	0,95	0,95	0,95	0,95	0,95
Max. inrush current (MIC)	(3)	A	87	115	116	128	139	141	165	204
Maximum inrush current with soft-starter (MIC)	(4)	A	57	75	75	84	92	94	109	135
Power supply	(7)		400V / 3ph / 50Hz							
Power supply	(8)		400V / 3ph+N / 50Hz							
Power supply for auxiliary circuits			230V-24V / 1ph / 50 Hz							
Suggested line section	(5) (7)	mm ²	4G6 FG7OR	4G10 FG7OR	4G10 FG7OR	4G10 FG7OR	4G16 FG7OR	4G16 FG7OR	4G16 FG7OR	4G25 FG7OR
Suggested line section	(5) (8)	mm ²	5G6 FG7OR	5G10 FG7OR	5G10 FG7OR	5G10 FG7OR	5G16 FG7OR	5G16 FG7OR	5G16 FG7OR	4G25 FG7OR
Suggested line protection	(6)		CH14gG 40A	NH00gG 50A	NH00gG 50A	NH00gG 50A	NH00gG 63A	NH00gG 63A	NH00gG 80A	NH00gG 100A
			12.2	13.2	15.2	17.2	19.2	20.2	24.2	27.2
General electrical specifications										
Max. absorbed power (FLI)	(1)	kW	43	50	56	61	69	76	87	94
Max. absorbed current (FLA)	(1)	A	67	73	81	89	104	119	143	153
Rated current (Inom)	(2)	A	59	65	73	81	98	109	126	133
cosφ standard unit	(2)		0,80	0,84	0,85	0,86	0,86	0,86	0,87	0,87
Nominal current with power factor correction (Inom)	(2)	A	50	58	64	73	89	98	114	120
cosφ unit with power factor correction	(2)		0,95	0,95	0,97	0,96	0,95	0,95	0,96	0,96
Max. inrush current (MIC)	(3)	A	255	262	309	317	355	369	338	375
Maximum inrush current with soft-starter (MIC)	(4)	A	165	172	200	208	231	245	232	256
Power supply	(7)		400V / 3ph / 50Hz							
Power supply	(8)		400V / 3ph+N / 50Hz							
Power supply for auxiliary circuits			230V-24V / 1ph / 50 Hz							
Suggested line section	(5) (7)	mm ²	4G25 FG7OR	4G25 FG7OR	3x35+1G25 FG7OR	3x35+1G25 FG7OR	3x50+1G25 FG7OR	3x70+1G35 FG7OR	3x95+1G50 FG7OR	3x95+1G50 FG7OR
Suggested line section	(5) (8)	mm ²	4G25 FG7OR	4G25 FG7OR	3x35+1G25 FG7OR	3x35+1G25 FG7OR	3x50+1G25 FG7OR	3x70+1G35 FG7OR	3x95+1G50 FG7OR	3x95+1G50 FG7OR
Suggested line protection	(6)		NH00gG 100A	NH00gG 100A	NH00gG 125A	NH00gG 125A	NH00gG 160A	NH1gG 200A	NH1gG 250A	NH1gG 250A
(1) Data regarding the unit without accessories working in maximum power absorption conditions										
(2) Datum related to the unit without accessories working in standard conditions (W30/35°C; W12-7°C)										
(3) Maximum effective RMS value of the current when the last compressor starts (FLA of the entire unit - FLA of the largest compressor + LRA of the largest compressor)										
(4) Maximum effective RMS value of the current when the last compressor starts (FLA of the entire unit - FLA of the largest compressor + 0.6 x LRA of the largest compressor)										
(5) These values are determined for cables with operating temperature of 40°C, EPR insulation and a line with a maximum length of 50m. The line section must be determined by a qualified technician based on the protection devices, the length of the line, the type of cable used and the type of installation.										
(6) The correct line protection part must be determined by a qualified technician based on the length of the line, the type of cable used and the type of installation.										
(7) Valid for all versions except LC and LC/HP										
(8) Valid only for the LC and LC/HP versions										

			30.3	34.3	40.3	18.4	20.4	24.4	26.4	30.4
General electrical specifications										
Max. absorbed power (FLI)	(1)	kW	114	130	141	62	74	87	100	111
Max. absorbed current (FLA)	(1)	A	178	214	230	102	121	134	146	162
Rated current (Inom)	(2)	A	161	190	201	91	103	118	131	145
cosφ standard unit	(2)		0,86	0,87	0,88	0,78	0,75	0,80	0,84	0,85
Nominal current with power factor correction (Inom)	(2)	A	146	172	184	75	81	97	113	127
cosφ unit with power factor correction	(2)		0,95	0,96	0,96	0,95	0,95	0,97	0,97	0,97
Max. inrush current (MIC)	(3)	A	429	410	451	216	265	322	335	390
Maximum inrush current with soft-starter (MIC)	(4)	A	305	303	332	160	195	232	245	281
Power supply	(7)		400V / 3ph / 50Hz							
Power supply	(8)		400V / 3ph+N / 50Hz							
Power supply for auxiliary circuits			230V-24V / 1ph / 50 Hz							
Suggested line section	(5) (7)	mm²	3x95+1G50 FG7OR	3x150+1G95 FG7OR	3x150+1G95 FG7OR	3x50+1G25 FG7OR	3x70+1G35 FG7OR	3x70+1G35 FG7OR	3x95+1G50 FG7OR	3x95+1G50 FG7OR
Suggested line section	(5) (8)	mm²	3x95+1G50 FG7OR	3x150+1G95 FG7OR	3x150+1G95 FG7OR	3x50+1G25 FG7OR	3x70+1G35 FG7OR	3x70+1G35 FG7OR	3x95+1G50 FG7OR	3x95+1G50 FG7OR
Suggested line protection	(6)		NH1gG 250A	NH2gG 315A	NH2gG 315A	NH00gG 160A	NH1gG 200A	NH1gG 200A	NH1gG 250A	NH1gG 250A

			34.4	38.4	40.4	48.4	54.4	56.6	60.6	
General electrical specifications										
Max. absorbed power (FLI)	(1)	kW	123	137	152	174	188	206	228	
Max. absorbed current (FLA)	(1)	A	178	208	237	285	307	312	356	
Rated current (Inom)	(2)	A	162	183	217	249	265	290	322	
cosφ standard unit	(2)		0,86	0,86	0,86	0,86	0,88	0,86	0,88	
Nominal current with power factor correction (Inom)	(2)	A	144	162	195	226	246	259	298	
cosφ unit with power factor correction	(2)		0,97	0,97	0,96	0,95	0,95	0,96	0,95	
Max. inrush current (MIC)	(3)	A	406	459	488	481	528	562	607	
Maximum inrush current with soft-starter (MIC)	(4)	A	297	335	364	374	409	438	483	
Power supply	(7)		400V / 3ph / 50Hz							
Power supply	(8)		400V / 3ph+N / 50Hz							
Power supply for auxiliary circuits			230V-24V / 1ph / 50 Hz							
Suggested line section	(5) (7)	mm²	3x150+1G95 FG7OR	3x150+1G95 FG7OR	3x150+1G95 FG7OR	3x150+1G95 FG7OR	2x(3x- 95+1G50) FG7OR	2x(3x- 95+1G50) FG7OR	2x(3x- 95+1G50) FG7OR	
Suggested line section	(5) (8)	mm²	3x150+1G95 FG7OR	3x150+1G95 FG7OR	3x150+1G95 FG7OR	3x150+1G95 FG7OR	2x(3x- 95+1G50) FG7OR	2x(3x- 95+1G50) FG7OR	2x(3x- 95+1G50) FG7OR	
Suggested line protection	(6)		NH2gG 315A	NH2gG 315A	NH2gG 400A	NH2gG 400A	NH3gG 500A	NH3gG 500A	NH3gG 500A	

- (1) Data regarding the unit without accessories working in maximum power absorption conditions
- (2) Datum related to the unit without accessories working in standard conditions (W30/35°C; W12-7°C)
- (3) Maximum effective RMS value of the current when the last compressor starts (FLA of the entire unit - FLA of the largest compressor + LRA of the largest compressor)
- (4) Maximum effective RMS value of the current when the last compressor starts (FLA of the entire unit - FLA of the largest compressor + 0.6 x LRA of the largest compressor)
- (5) These values are determined for cables with operating temperature of 40°C, EPR insulation and a line with a maximum length of 50m. The line section must be determined by a qualified technician based on the protection devices, the length of the line, the type of cable used and the type of installation.
- (6) The correct line protection part must be determined by a qualified technician based on the length of the line, the type of cable used and the type of installation.
- (7) Valid for all versions except LC and LC/HP
- (8) Valid only for the LC and LC/HP versions

TETRIS W REV

			3.2	4.2	5.2	6.2	7.2	8.2	9.2
User-side hydraulic modules									
Volume of the expansion vessel		l	5	5	5	18	18	18	18
Volume of the buffer tank		l	200	200	200	200	200	200	200
Standard pumps									
Pump model standard			P1	P2	P4	P4	P4	P4	P7
Available head (1P)	(1)	kPa	117	154	159	156	144	127	129
Available head (2P)	(1)	kPa	120	158	163	162	151	137	141
Oversize pumps									
Pump model oversized			P3	P3	P5	P5	P5	P6	P8
Available head (1PM)	(1)	kPa	201	201	201	201	201	201	201
Available head (2PM)	(1)	kPa	204	204	204	204	204	204	204
Pumps for glycol									
Pump model for high glycol			P5	P5	P5	P5	P8	P8	P8
Available head (1PG)	(1)	kPa	205	199	191	189	181	167	155
Available head (2PG)	(1)	kPa	201	194	184	181	170	153	137
Source-side/heat recovery-side hydraulic modules									
Volume of the expansion vessel		l	5	5	5	18	18	18	18
Standard pumps									
Pump model standard			P4	P4	P4	P4	P4	P7	P7
Available head (1S o 1R)	(1)	kPa	151	142	133	128	109	145	132
Available head (2S o 2R)	(1)	kPa	155	147	139	136	119	149	137
Oversize pumps									
Pump model oversized			P5	P5	P5	P5	P5	P8	P8
Available head (1SM o 1RM)	(1)	kPa	196	188	178	174	154	183	170
Available head (2SM o 2RM)	(1)	kPa	200	193	185	182	165	187	176
Pumps for glycol									
Pump model for high glycol			P5	P5	P5	P8	P8	P8	P8
Available head (1SG o 2RG)	(1)	kPa	168	156	143	146	127	153	136
Available head (2SG o 2RG)	(1)	kPa	161	147	132	133	108	146	127

			10.2	12.2	13.2	15.2	17.2	19.2	20.2
User-side hydraulic modules									
Volume of the expansion vessel		l	18	18	18	18	18	18	18
Volume of the buffer tank		l	200	200	200	200	200	200	200
Standard pumps									
Pump model standard			P7	P8	P8	P10	P10	P10	P11
Available head (1P)	(1)	kPa	101	152	133	143	128	100	153
Available head (2P)	(1)	kPa	119	159	143	155	142	119	163
Oversize pumps									
Pump model oversized			P9	P9	P10	P11	P11	P11	P12
Available head (1PM)	(1)	kPa	201	201	201	201	201	201	201
Available head (2PM)	(1)	kPa	204	204	204	204	204	204	204
Pumps for glycol									
Pump model for high glycol			P10	P11	P12	P13	P14	P15	P15
Available head (1PG)	(1)	kPa	141	216	270	327	157	212	211
Available head (2PG)	(1)	kPa	114	206	256	310	136	184	196
Source-side/heat recovery-side hydraulic modules									
Volume of the expansion vessel		l	18	18	18	18	18	18	18
Standard pumps									
Pump model standard			P7	P8	P10	P10	P10	P10	P14
Available head (1S o 1R)	(1)	kPa	105	127	143	129	110	74	136
Available head (2S o 2R)	(1)	kPa	113	137	150	136	119	87	151
Oversize pumps									
Pump model oversized			P10	P10	P11	P11	P11	P15	P15
Available head (1SM o 1RM)	(1)	kPa	162	150	205	188	165	219	202
Available head (2SM o 2RM)	(1)	kPa	170	160	212	196	175	231	217
Pumps for glycol									
Pump model for high glycol			P12	P13	P14	P14	P14	P15	P15
Available head (1SG o 2RG)	(1)	kPa	259	318	154	145	135	175	152
Available head (2SG o 2RG)	(1)	kPa	245	301	144	133	119	154	127

(1) Source side heat exchanger inlet/outlet water temperature 30/35°C; user side heat exchanger inlet/outlet water temperature 12/7°C. Values compliant with standard EN 14511

TETRIS W REV

			24.2	27.2	30.3	34.3	40.3	18.4	20.4
User-side hydraulic modules									
Volume of the expansion vessel		l	18	18	18	18	18	18	18
Volume of the buffer tank		l	270	270	400	400	400	270	270
Standard pumps									
Pump model standard			P14	P14	P14	P14	P15	P10	P10
Available head (1P)	(1)	kPa	147	131	126	102	126	134	114
Available head (2P)	(1)	kPa	159	147	136	115	142	149	124
Oversize pumps									
Pump model oversized			P15	P15	P15	P15	P16	P11	P11
Available head (1PM)	(1)	kPa	201	201	201	201	201	201	201
Available head (2PM)	(1)	kPa	204	204	204	204	204	204	204
Pumps for glycol									
Pump model for high glycol			P15	P15	P19	P19	P19	P14	P15
Available head (1PG)	(1)	kPa	189	168	199	185	178	169	228
Available head (2PG)	(1)	kPa	170	144	184	166	155	147	213
Source-side/heat recovery-side hydraulic modules									
Volume of the expansion vessel		l	18	18	18	18	18	18	18
Standard pumps									
Pump model standard			P14	P14	P14	P14	P17	P10	P14
Available head (1S o 1R)	(1)	kPa	142	114	99	75	88	118	155
Available head (2S o 2R)	(1)	kPa	160	138	114	93	110	127	169
Oversize pumps									
Pump model oversized			P15	P15	P18	P18	P19	P11	P15
Available head (1SM o 1RM)	(1)	kPa	205	173	167	160	191	173	221
Available head (2SM o 2RM)	(1)	kPa	223	196	182	178	213	183	236
Pumps for glycol									
Pump model for high glycol			P15	P19	P19	P20	P20	P14	P15
Available head (1SG o 2RG)	(1)	kPa	158	180	176	202	181	152	176
Available head (2SG o 2RG)	(1)	kPa	127	141	151	171	143	135	151

			24.4	26.4	30.4	34.4	38.4	40.4
User-side hydraulic modules								
Volume of the expansion vessel		l	18	18	18	18	18	18
Volume of the buffer tank		l	270	270	400	400	400	400
Standard pumps								
Pump model standard			P14	P14	P14	P14	P14	P18
Available head (1P)	(1)	kPa	163	150	158	144	106	156
Available head (2P)	(1)	kPa	176	167	167	155	121	174
Oversize pumps								
Pump model oversized			P15	P15	P15	P15	P16	P19
Available head (1PM)	(1)	kPa	201	201	201	201	201	201
Available head (2PM)	(1)	kPa	204	204	204	204	204	204
Pumps for glycol								
Pump model for high glycol			P15	P15	P15	P19	P19	P19
Available head (1PG)	(1)	kPa	212	195	188	229	201	183
Available head (2PG)	(1)	kPa	193	170	175	213	180	157
Source-side/heat recovery-side hydraulic modules								
Volume of the expansion vessel		l	18	18	18	18	18	18
Standard pumps								
Pump model standard			P14	P14	P14	P15	P17	P18
Available head (1S o 1R)	(1)	kPa	135	113	121	141	89	116
Available head (2S o 2R)	(1)	kPa	154	137	133	157	109	141
Oversize pumps								
Pump model oversized			P15	P15	P15	P16	P19	P19
Available head (1SM o 1RM)	(1)	kPa	198	171	173	230	191	163
Available head (2SM o 2RM)	(1)	kPa	217	195	185	245	211	188
Pumps for glycol								
Pump model for high glycol			P15	P19	P19	P19	P20	P21
Available head (1SG o 2RG)	(1)	kPa	151	180	193	177	177	211
Available head (2SG o 2RG)	(1)	kPa	119	140	172	150	142	168

(1) Source side heat exchanger inlet/outlet water temperature 30/35°C; user side heat exchanger inlet/outlet water temperature 12/7°C. Values compliant with standard EN 14511

TETRIS W REV

			48.4	54.4	56.6	60.6
User-side hydraulic modules						
Volume of the expansion vessel		l	25	25	25	25
Volume of the buffer tank		l	400	400	400	400
Standard pumps						
Pump model standard			P18	P18	P18	P18
Available head (1P)	(1)	kPa	160	135	164	137
Available head (2P)	(1)	kPa	182	163	171	147
Oversize pumps						
Pump model oversized			P19	P19	P19	P20
Available head (1PM)	(1)	kPa	201	201	201	201
Available head (2PM)	(1)	kPa	204	204	204	204
Pumps for glycol						
Pump model for high glycol			P20	P23	P23	P23
Available head (1PG)	(1)	kPa	228	226	241	217
Available head (2PG)	(1)	kPa	195	185	229	202
Source-side/heat recovery-side hydraulic modules						
Volume of the expansion vessel		l	25	25	25	25
Standard pumps						
Pump model standard			P18	P22	P22	P22
Available head (1S o 1R)	(1)	kPa	157	184	171	141
Available head (2S o 2R)	(1)	kPa	165	194	182	156
Oversize pumps						
Pump model oversized			P20	P23	P23	P23
Available head (1SM o 1RM)	(1)	kPa	238	242	229	202
Available head (2SM o 2RM)	(1)	kPa	246	252	241	216
Pumps for glycol						
Pump model for high glycol			P22	P23	P23	P23
Available head (1SG o 2RG)	(1)	kPa	153	190	171	133
Available head (2SG o 2RG)	(1)	kPa	139	173	151	108

(1) Source side heat exchanger inlet/outlet water temperature 30/35°C; user side heat exchanger inlet/outlet water temperature 12/7°C. Values compliant with standard EN 14511

TETRIS W REV /HP

			3.2	4.2	5.2	6.2	7.2	8.2	9.2
User-side hydraulic modules									
Volume of the expansion vessel		l	5	5	5	18	18	18	18
Volume of the buffer tank		l	200	200	200	200	200	200	200
Standard pumps									
Pump model standard			P1	P2	P4	P4	P4	P4	P7
Available head (1P)	(1)	kPa	117	154	159	156	144	127	129
Available head (2P)	(1)	kPa	120	158	163	162	151	137	141
Oversize pumps									
Pump model oversized			P3	P3	P5	P5	P5	P6	P8
Available head (1PM)	(1)	kPa	201	201	201	201	201	201	201
Available head (2PM)	(1)	kPa	204	204	204	204	204	204	204
Pumps for glycol									
Pump model for high glycol			P5	P5	P5	P5	P8	P8	P8
Available head (1PG)	(1)	kPa	205	199	191	189	181	167	155
Available head (2PG)	(1)	kPa	201	194	184	181	170	153	137
Source-side hydraulic modules									
Volume of the expansion vessel		l	5	5	5	18	18	18	18
Standard pumps									
Pump model standard			P4	P4	P4	P4	P4	P7	P7
Available head (1S)	(1)	kPa	151	142	133	128	109	145	132
Available head (2S)	(1)	kPa	155	147	139	136	119	149	137
Oversize pumps									
Pump model oversized			P5	P5	P5	P5	P5	P8	P8
Available head (1SM)	(1)	kPa	196	188	178	174	154	183	170
Available head (2SM)	(1)	kPa	200	193	185	182	165	187	176
Pumps for glycol									
Pump model for high glycol			P5	P5	P5	P8	P8	P8	P8
Available head (1SG)	(1)	kPa	168	156	143	146	127	153	136
Available head (2SG)	(1)	kPa	161	147	132	133	108	146	127

(1) Source side heat exchanger inlet/outlet water temperature 30/35°C; user side heat exchanger inlet/outlet water temperature 12/7°C. Values compliant with standard EN 14511

TETRIS W REV /HP

			10.2	12.2	13.2	15.2	17.2	19.2	20.2
User-side hydraulic modules									
Volume of the expansion vessel		l	18	18	18	18	18	18	18
Volume of the buffer tank		l	200	200	200	200	200	200	200
Standard pumps									
Pump model standard			P7	P8	P8	P10	P10	P10	P11
Available head (1P)	(1)	kPa	101	152	133	143	128	100	153
Available head (2P)	(1)	kPa	119	159	143	155	142	119	163
Oversize pumps									
Pump model oversized			P9	P9	P10	P11	P11	P11	P12
Available head (1PM)	(1)	kPa	201	201	201	201	201	201	201
Available head (2PM)	(1)	kPa	204	204	204	204	204	204	204
Pumps for glycol									
Pump model for high glycol			P10	P11	P12	P13	P14	P15	P15
Available head (1PG)	(1)	kPa	141	216	270	327	157	212	211
Available head (2PG)	(1)	kPa	114	206	256	310	136	184	196
Source-side hydraulic modules									
Volume of the expansion vessel		l	18	18	18	18	18	18	18
Standard pumps									
Pump model standard			P7	P8	P10	P10	P10	P10	P14
Available head (1S)	(1)	kPa	105	127	143	129	110	74	136
Available head (2S)	(1)	kPa	113	137	150	136	119	87	151
Oversize pumps									
Pump model oversized			P10	P10	P11	P11	P11	P15	P15
Available head (1SM)	(1)	kPa	162	150	205	188	165	219	202
Available head (2SM)	(1)	kPa	170	160	212	196	175	231	217
Pumps for glycol									
Pump model for high glycol			P12	P13	P14	P14	P14	P15	P15
Available head (1SG)	(1)	kPa	259	318	154	145	135	175	152
Available head (2SG)	(1)	kPa	245	301	144	133	119	154	127

			24.2	27.2	30.3	34.3	40.3	18.4	20.4
User-side hydraulic modules									
Volume of the expansion vessel		l	18	18	18	18	18	18	18
Volume of the buffer tank		l	270	270	400	400	400	270	270
Standard pumps									
Pump model standard			P14	P14	P14	P14	P15	P10	P10
Available head (1P)	(1)	kPa	147	131	126	102	126	134	114
Available head (2P)	(1)	kPa	159	147	136	115	142	149	124
Oversize pumps									
Pump model oversized			P15	P15	P15	P15	P16	P11	P11
Available head (1PM)	(1)	kPa	201	201	201	201	201	201	201
Available head (2PM)	(1)	kPa	204	204	204	204	204	204	204
Pumps for glycol									
Pump model for high glycol			P15	P15	P19	P19	P19	P14	P15
Available head (1PG)	(1)	kPa	189	168	199	185	178	169	228
Available head (2PG)	(1)	kPa	170	144	184	166	155	147	213
Source-side hydraulic modules									
Volume of the expansion vessel		l	18	18	18	18	18	18	18
Standard pumps									
Pump model standard			P14	P14	P14	P14	P17	P10	P14
Available head (1S)	(1)	kPa	142	114	99	75	88	118	155
Available head (2S)	(1)	kPa	160	138	114	93	110	127	169
Oversize pumps									
Pump model oversized			P15	P15	P18	P18	P19	P11	P15
Available head (1SM)	(1)	kPa	205	173	167	160	191	173	221
Available head (2SM)	(1)	kPa	223	196	182	178	213	183	236
Pumps for glycol									
Pump model for high glycol			P15	P19	P19	P20	P20	P14	P15
Available head (1SG)	(1)	kPa	158	180	176	202	181	152	176
Available head (2SG)	(1)	kPa	127	141	151	171	143	135	151

(1) Source side heat exchanger inlet/outlet water temperature 30/35°C; user side heat exchanger inlet/outlet water temperature 12/7°C. Values compliant with standard EN 14511

TETRIS W REV /HP

			24.4	26.4	30.4	34.4	38.4
User-side hydraulic modules							
Volume of the expansion vessel		l	18	18	18	18	18
Volume of the buffer tank		l	270	270	400	400	400
Standard pumps							
Pump model standard			P14	P14	P14	P14	P14
Available head (1P)	(1)	kPa	163	150	158	144	106
Available head (2P)	(1)	kPa	176	167	167	155	121
Oversize pumps							
Pump model oversized			P15	P15	P15	P15	P16
Available head (1PM)	(1)	kPa	201	201	201	201	201
Available head (2PM)	(1)	kPa	204	204	204	204	204
Pumps for glycol							
Pump model for high glycol			P15	P15	P15	P19	P19
Available head (1PG)	(1)	kPa	212	195	188	229	201
Available head (2PG)	(1)	kPa	193	170	175	213	180
Source-side hydraulic modules							
Volume of the expansion vessel		l	18	18	18	18	18
Standard pumps							
Pump model standard			P14	P14	P14	P15	P17
Available head (1S)	(1)	kPa	135	113	121	141	89
Available head (2S)	(1)	kPa	154	137	133	157	109
Oversize pumps							
Pump model oversized			P15	P15	P15	P16	P19
Available head (1SM)	(1)	kPa	198	171	173	230	191
Available head (2SM)	(1)	kPa	217	195	185	245	211
Pumps for glycol							
Pump model for high glycol			P15	P19	P19	P19	P20
Available head (1SG)	(1)	kPa	151	180	193	177	177
Available head (2SG)	(1)	kPa	119	140	172	150	142

			40.4	48.4	54.4	56.6	60.6
User-side hydraulic modules							
Volume of the expansion vessel		l	18	25	25	25	25
Volume of the buffer tank		l	400	400	400	400	400
Standard pumps							
Pump model standard			P18	P18	P18	P18	P18
Available head (1P)	(1)	kPa	156	160	135	164	137
Available head (2P)	(1)	kPa	174	182	163	171	147
Oversize pumps							
Pump model oversized			P19	P19	P19	P19	P20
Available head (1PM)	(1)	kPa	201	201	201	201	201
Available head (2PM)	(1)	kPa	204	204	204	204	204
Pumps for glycol							
Pump model for high glycol			P19	P20	P23	P23	P23
Available head (1PG)	(1)	kPa	183	228	226	241	217
Available head (2PG)	(1)	kPa	157	195	185	229	202
Source-side hydraulic modules							
Volume of the expansion vessel		l	18	25	25	25	25
Standard pumps							
Pump model standard			P18	P18	P22	P22	P22
Available head (1S)	(1)	kPa	116	157	184	171	141
Available head (2S)	(1)	kPa	141	165	194	182	156
Oversize pumps							
Pump model oversized			P19	P20	P23	P23	P23
Available head (1SM)	(1)	kPa	163	238	242	229	202
Available head (2SM)	(1)	kPa	188	246	252	241	216
Pumps for glycol							
Pump model for high glycol			P21	P22	P23	P23	P23
Available head (1SG)	(1)	kPa	211	153	190	171	133
Available head (2SG)	(1)	kPa	168	139	173	151	108

(1) Source side heat exchanger inlet/outlet water temperature 30/35°C; user side heat exchanger inlet/outlet water temperature 12/7°C. Values compliant with standard EN 14511

TETRIS W REV /OH

			3.2	4.2	5.2	6.2	7.2	8.2	9.2
User-side hydraulic modules									
Volume of the expansion vessel		l	5	5	5	18	18	18	18
Standard pumps									
Pump model standard			P4	P4	P4	P4	P4	P7	P7
Available head (1P)	(1)	kPa	151	142	133	128	109	145	132
Available head (2P)	(1)	kPa	155	147	139	136	119	149	137
Oversize pumps									
Pump model oversized			P5	P5	P5	P5	P5	P8	P8
Available head (1PM)	(1)	kPa	196	188	178	174	154	183	170
Available head (2PM)	(1)	kPa	200	193	185	182	165	187	176
Pumps for glycol									
Pump model for high glycol			P5	P5	P5	P5	P8	P8	P8
Available head (1PG)	(1)	kPa	205	199	191	189	181	167	155
Available head (2PG)	(1)	kPa	201	194	184	181	170	153	137
Source-side hydraulic modules									
Volume of the expansion vessel		l	5	5	5	18	18	18	18
Standard pumps									
Pump model standard			P1	P2	P4	P4	P4	P4	P7
Available head (1S)	(1)	kPa	117	154	159	156	144	127	129
Available head (2S)	(1)	kPa	120	158	163	162	151	137	141
Oversize pumps									
Pump model oversized			P3	P3	P5	P5	P5	P6	P8
Available head (1SM)	(1)	kPa	201	201	201	201	201	201	201
Available head (2SM)	(1)	kPa	204	204	204	204	204	204	204
Pumps for glycol									
Pump model for high glycol			P5	P5	P5	P5	P8	P8	P8
Available head (1SG)	(1)	kPa	205	199	191	189	181	167	155
Available head (2SG)	(1)	kPa	201	194	184	181	170	153	137

			10.2	12.2	13.2	15.2	17.2	19.2	20.2
User-side hydraulic modules									
Volume of the expansion vessel		l	18	18	18	18	18	18	18
Standard pumps									
Pump model standard			P7	P8	P10	P10	P10	P10	P14
Available head (1P)	(1)	kPa	105	127	143	129	110	74	136
Available head (2P)	(1)	kPa	113	137	150	136	119	87	151
Oversize pumps									
Pump model oversized			P10	P10	P11	P11	P11	P15	P15
Available head (1PM)	(1)	kPa	162	150	205	188	165	219	202
Available head (2PM)	(1)	kPa	170	160	212	196	175	231	217
Pumps for glycol									
Pump model for high glycol			P10	P11	P12	P13	P14	P15	P15
Available head (1PG)	(1)	kPa	141	216	270	327	157	212	211
Available head (2PG)	(1)	kPa	114	206	256	310	136	184	196
Source-side hydraulic modules									
Volume of the expansion vessel		l	18	18	18	18	18	18	18
Standard pumps									
Pump model standard			P7	P8	P8	P10	P10	P10	P11
Available head (1S)	(1)	kPa	101	152	133	143	128	100	153
Available head (2S)	(1)	kPa	119	159	143	155	142	119	163
Oversize pumps									
Pump model oversized			P9	P9	P10	P11	P11	P11	P12
Available head (1SM)	(1)	kPa	201	201	201	201	201	201	201
Available head (2SM)	(1)	kPa	204	204	204	204	204	204	204
Pumps for glycol									
Pump model for high glycol			P10	P11	P12	P13	P14	P15	P15
Available head (1SG)	(1)	kPa	141	216	270	327	157	212	211
Available head (2SG)	(1)	kPa	114	206	256	310	136	184	196

(1) Source side heat exchanger inlet/outlet water temperature 30/35°C; user side heat exchanger inlet/outlet water temperature 12/7°C. Values compliant with standard EN 14511

TETRIS W REV /OH

			24.2	27.2	30.3	34.3	40.3	18.4	20.4
User-side hydraulic modules									
Volume of the expansion vessel		l	18	18	18	18	18	18	18
Standard pumps									
Pump model standard			P14	P14	P14	P14	P17	P10	P14
Available head (1P)	(1)	kPa	142	114	99	75	88	118	155
Available head (2P)	(1)	kPa	160	138	114	93	110	127	169
Oversize pumps									
Pump model oversized			P15	P15	P18	P18	P19	P11	P15
Available head (1PM)	(1)	kPa	205	173	167	160	191	173	221
Available head (2PM)	(1)	kPa	223	196	182	178	213	183	236
Pumps for glycol									
Pump model for high glycol			P15	P15	P19	P19	P19	P14	P15
Available head (1PG)	(1)	kPa	189	168	199	185	178	169	228
Available head (2PG)	(1)	kPa	170	144	184	166	155	147	213
Source-side hydraulic modules									
Volume of the expansion vessel		l	18	18	18	18	18	18	18
Standard pumps									
Pump model standard			P14	P14	P14	P14	P15	P10	P10
Available head (1S)	(1)	kPa	147	131	126	102	126	134	114
Available head (2S)	(1)	kPa	159	147	136	115	142	149	124
Oversize pumps									
Pump model oversized			P15	P15	P15	P15	P16	P11	P11
Available head (1SM)	(1)	kPa	201	201	201	201	201	201	201
Available head (2SM)	(1)	kPa	204	204	204	204	204	204	204
Pumps for glycol									
Pump model for high glycol			P15	P15	P19	P19	P19	P14	P15
Available head (1SG)	(1)	kPa	189	168	199	185	178	169	228
Available head (2SG)	(1)	kPa	170	144	184	166	155	147	213

			24.4	26.4	30.4	34.4	38.4	40.4
User-side hydraulic modules								
Volume of the expansion vessel		l	18	18	18	18	18	18
Standard pumps								
Pump model standard			P14	P14	P14	P15	P17	P18
Available head (1P)	(1)	kPa	135	113	121	141	89	116
Available head (2P)	(1)	kPa	154	137	133	157	109	141
Oversize pumps								
Pump model oversized			P15	P15	P15	P16	P19	P19
Available head (1PM)	(1)	kPa	198	171	173	230	191	163
Available head (2PM)	(1)	kPa	217	195	185	245	211	188
Pumps for glycol								
Pump model for high glycol			P15	P15	P15	P19	P19	P19
Available head (1PG)	(1)	kPa	212	195	188	229	201	183
Available head (2PG)	(1)	kPa	193	170	175	213	180	157
Source-side hydraulic modules								
Volume of the expansion vessel		l	18	18	18	18	18	18
Standard pumps								
Pump model standard			P14	P14	P14	P14	P14	P18
Available head (1S)	(1)	kPa	163	150	158	144	106	156
Available head (2S)	(1)	kPa	176	167	167	155	121	174
Oversize pumps								
Pump model oversized			P15	P15	P15	P15	P16	P19
Available head (1SM)	(1)	kPa	201	201	201	201	201	201
Available head (2SM)	(1)	kPa	204	204	204	204	204	204
Pumps for glycol								
Pump model for high glycol			P15	P15	P15	P19	P19	P19
Available head (1SG)	(1)	kPa	212	195	188	229	201	183
Available head (2SG)	(1)	kPa	193	170	175	213	180	157

(1) Source side heat exchanger inlet/outlet water temperature 30/35°C; user side heat exchanger inlet/outlet water temperature 12/7°C. Values compliant with standard EN 14511

TETRIS W REV /OH

			48.4	54.4	56.6	60.6
User-side hydraulic modules						
Volume of the expansion vessel		l	25	25	25	25
Standard pumps						
Pump model standard			P18	P22	P22	P22
Available head (1P)	(1)	kPa	157	184	171	141
Available head (2P)	(1)	kPa	165	194	182	156
Oversize pumps						
Pump model oversized			P20	P23	P23	P23
Available head (1PM)	(1)	kPa	238	242	229	202
Available head (2PM)	(1)	kPa	246	252	241	216
Pumps for glycol						
Pump model for high glycol			P20	P23	P23	P23
Available head (1PG)	(1)	kPa	228	226	241	217
Available head (2PG)	(1)	kPa	195	185	229	202
Source-side hydraulic modules						
Volume of the expansion vessel		l	25	25	25	25
Standard pumps						
Pump model standard			P18	P18	P18	P18
Available head (1S)	(1)	kPa	160	135	164	137
Available head (2S)	(1)	kPa	182	163	171	147
Oversize pumps						
Pump model oversized			P19	P19	P19	P20
Available head (1SM)	(1)	kPa	201	201	201	201
Available head (2SM)	(1)	kPa	204	204	204	204
Pumps for glycol						
Pump model for high glycol			P20	P23	P23	P23
Available head (1SG)	(1)	kPa	228	226	241	217
Available head (2SG)	(1)	kPa	195	185	229	202

(1) Source side heat exchanger inlet/outlet water temperature 30/35°C; user side heat exchanger inlet/outlet water temperature 12/7°C. Values compliant with standard EN 14511

TETRIS W REV /HPW

			3.2	4.2	5.2	6.2	7.2	8.2	9.2
User-side hydraulic modules									
Volume of the buffer tank		l	5	5	5	18	18	18	18
Standard pumps									
Pump model standard			P1	P2	P4	P4	P4	P4	P7
Available head (1P)	(1)	kPa	117	154	159	156	144	127	129
Available head (2P)	(1)	kPa	120	158	163	162	151	137	141
Oversize pumps									
Pump model oversized			P3	P3	P5	P5	P5	P6	P8
Available head (1PM)	(1)	kPa	201	201	201	201	201	201	201
Available head (2PM)	(1)	kPa	204	204	204	204	204	204	204
Pumps for glycol									
Pump model for high glycol			P5	P5	P5	P5	P8	P8	P8
Available head (1PG)	(1)	kPa	205	199	191	189	181	167	155
Available head (2PG)	(1)	kPa	201	194	184	181	170	153	137
Source-side hydraulic modules									
Volume of the expansion vessel		l	5	5	5	18	18	18	18
Standard pumps									
Pump model standard			P4	P4	P4	P4	P4	P7	P7
Available head (1S)	(1)	kPa	151	142	133	128	109	145	132
Available head (2S)	(1)	kPa	155	147	139	136	119	149	137
Oversize pumps									
Pump model oversized			P5	P5	P5	P5	P5	P8	P8
Available head (1SM)	(1)	kPa	196	188	178	174	154	183	170
Available head (2SM)	(1)	kPa	200	193	185	182	165	187	176
Pumps for glycol									
Pump model for high glycol			P5	P5	P5	P8	P8	P8	P8
Available head (1SG)	(1)	kPa	168	156	143	146	127	153	136
Available head (2SG)	(1)	kPa	161	147	132	133	108	146	127

(1) Source side heat exchanger inlet/outlet water temperature 30/35°C; user side heat exchanger inlet/outlet water temperature 12/7°C. Values compliant with standard EN 14511

TETRIS W REV /HPW

			10.2	12.2	13.2	15.2	17.2	19.2	20.2
User-side hydraulic modules									
Volume of the buffer tank		l	18	18	18	18	18	18	18
Standard pumps									
Pump model standard			P7	P8	P8	P10	P10	P10	P11
Available head (1P)	(1)	kPa	101	152	133	143	128	100	153
Available head (2P)	(1)	kPa	119	159	143	155	142	119	163
Oversize pumps									
Pump model oversized			P9	P9	P10	P11	P11	P11	P12
Available head (1PM)	(1)	kPa	201	201	201	201	201	201	201
Available head (2PM)	(1)	kPa	204	204	204	204	204	204	204
Pumps for glycol									
Pump model for high glycol			P10	P11	P12	P13	P14	P15	P15
Available head (1PG)	(1)	kPa	141	216	270	327	157	212	211
Available head (2PG)	(1)	kPa	114	206	256	310	136	184	196
Source-side hydraulic modules									
Volume of the expansion vessel		l	18	18	18	18	18	18	18
Standard pumps									
Pump model standard			P7	P8	P10	P10	P10	P10	P14
Available head (1S)	(1)	kPa	105	127	143	129	110	74	136
Available head (2S)	(1)	kPa	113	137	150	136	119	87	151
Oversize pumps									
Pump model oversized			P10	P10	P11	P11	P11	P15	P15
Available head (1SM)	(1)	kPa	162	150	205	188	165	219	202
Available head (2SM)	(1)	kPa	170	160	212	196	175	231	217
Pumps for glycol									
Pump model for high glycol			P12	P13	P14	P14	P14	P15	P15
Available head (1SG)	(1)	kPa	259	318	154	145	135	175	152
Available head (2SG)	(1)	kPa	245	301	144	133	119	154	127

			24.2	27.2	30.3	34.3	40.3	18.4	20.4
User-side hydraulic modules									
Volume of the buffer tank		l	18	18	18	18	18	18	18
Standard pumps									
Pump model standard			P14	P14	P14	P14	P15	P10	P10
Available head (1P)	(1)	kPa	147	131	126	102	126	134	114
Available head (2P)	(1)	kPa	159	147	136	115	142	149	124
Oversize pumps									
Pump model oversized			P15	P15	P15	P15	P16	P11	P11
Available head (1PM)	(1)	kPa	201	201	201	201	201	201	201
Available head (2PM)	(1)	kPa	204	204	204	204	204	204	204
Pumps for glycol									
Pump model for high glycol			P15	P15	P19	P19	P19	P14	P15
Available head (1PG)	(1)	kPa	189	168	199	185	178	169	228
Available head (2PG)	(1)	kPa	170	144	184	166	155	147	213
Source-side hydraulic modules									
Volume of the expansion vessel		l	18	18	18	18	18	18	18
Standard pumps									
Pump model standard			P14	P14	P14	P14	P17	P10	P14
Available head (1S)	(1)	kPa	142	114	99	75	88	118	155
Available head (2S)	(1)	kPa	160	138	114	93	110	127	169
Oversize pumps									
Pump model oversized			P15	P15	P18	P18	P19	P11	P15
Available head (1SM)	(1)	kPa	205	173	167	160	191	173	221
Available head (2SM)	(1)	kPa	223	196	182	178	213	183	236
Pumps for glycol									
Pump model for high glycol			P15	P19	P19	P20	P20	P14	P15
Available head (1SG)	(1)	kPa	158	180	176	202	181	152	176
Available head (2SG)	(1)	kPa	127	141	151	171	143	135	151

(1) Source side heat exchanger inlet/outlet water temperature 30/35°C; user side heat exchanger inlet/outlet water temperature 12/7°C. Values compliant with standard EN 14511

TETRIS W REV /HPW

			24.4	26.4	30.4	34.4	38.4
User-side hydraulic modules							
Volume of the buffer tank		l	18	18	18	18	18
Standard pumps							
Pump model standard			P14	P14	P14	P14	P14
Available head (1P)	(1)	kPa	163	150	158	144	106
Available head (2P)	(1)	kPa	176	167	167	155	121
Oversize pumps							
Pump model oversized			P15	P15	P15	P15	P16
Available head (1PM)	(1)	kPa	201	201	201	201	201
Available head (2PM)	(1)	kPa	204	204	204	204	204
Pumps for glycol							
Pump model for high glycol			P15	P15	P15	P19	P19
Available head (1PG)	(1)	kPa	212	195	188	229	201
Available head (2PG)	(1)	kPa	193	170	175	213	180
Source-side hydraulic modules							
Volume of the expansion vessel		l	18	18	18	18	18
Standard pumps							
Pump model standard			P14	P14	P14	P15	P17
Available head (1S)	(1)	kPa	135	113	121	141	89
Available head (2S)	(1)	kPa	154	137	133	157	109
Oversize pumps							
Pump model oversized			P15	P15	P15	P16	P19
Available head (1SM)	(1)	kPa	198	171	173	230	191
Available head (2SM)	(1)	kPa	217	195	185	245	211
Pumps for glycol							
Pump model for high glycol			P15	P19	P19	P19	P20
Available head (1SG)	(1)	kPa	151	180	193	177	177
Available head (2SG)	(1)	kPa	119	140	172	150	142

			40.4	48.4	54.4	56.6	60.6
User-side hydraulic modules							
Volume of the buffer tank		l	18	25	25	25	25
Standard pumps							
Pump model standard			P18	P18	P18	P18	P18
Available head (1P)	(1)	kPa	156	160	135	164	137
Available head (2P)	(1)	kPa	174	182	163	171	147
Oversize pumps							
Pump model oversized			P19	P19	P19	P19	P20
Available head (1PM)	(1)	kPa	201	201	201	201	201
Available head (2PM)	(1)	kPa	204	204	204	204	204
Pumps for glycol							
Pump model for high glycol			P19	P20	P23	P23	P23
Available head (1PG)	(1)	kPa	183	228	226	241	217
Available head (2PG)	(1)	kPa	157	195	185	229	202
Source-side hydraulic modules							
Volume of the expansion vessel		l	18	25	25	25	25
Standard pumps							
Pump model standard			P18	P18	P22	P22	P22
Available head (1S)	(1)	kPa	116	157	184	171	141
Available head (2S)	(1)	kPa	141	165	194	182	156
Oversize pumps							
Pump model oversized			P19	P20	P23	P23	P23
Available head (1SM)	(1)	kPa	163	238	242	229	202
Available head (2SM)	(1)	kPa	188	246	252	241	216
Pumps for glycol							
Pump model for high glycol			P21	P22	P23	P23	P23
Available head (1SG)	(1)	kPa	211	153	190	171	133
Available head (2SG)	(1)	kPa	168	139	173	151	108

(1) Source side heat exchanger inlet/outlet water temperature 30/35°C; user side heat exchanger inlet/outlet water temperature 12/7°C. Values compliant with standard EN 14511

TETRIS W REV LC

			3.2	4.2	5.2	6.2	7.2	8.2	9.2
User-side hydraulic modules									
Volume of the expansion vessel		l	5	5	5	18	18	18	18
Volume of the buffer tank		l	200	200	200	200	200	200	200
Standard pumps									
Standard pump model			P1	P2	P4	P4	P4	P4	P7
Available head (1P)	(1)	kPa	117	154	159	156	144	127	129
Available head (2P)	(1)	kPa	120	158	163	162	151	137	141
Oversize pumps									
Oversize pump model			P3	P3	P5	P5	P5	P6	P8
Available head (1PM)	(1)	kPa	201	201	201	201	201	201	201
Available head (2PM)	(1)	kPa	204	204	204	204	204	204	204
Pumps for glycol									
Pump model for high glycol			P5	P5	P5	P5	P8	P8	P8
Available head (1PG)	(1)	kPa	205	199	191	189	181	167	155
Available head (2PG)	(1)	kPa	201	194	184	181	170	153	137

			10.2	12.2	13.2	15.2	17.2	19.2	20.2
User-side hydraulic modules									
Volume of the expansion vessel		l	18	18	18	18	18	18	18
Volume of the buffer tank		l	200	200	200	200	200	200	200
Standard pumps									
Standard pump model			P7	P8	P8	P10	P10	P10	P11
Available head (1P)	(1)	kPa	101	152	133	143	128	100	153
Available head (2P)	(1)	kPa	119	159	143	155	142	119	163
Oversize pumps									
Oversize pump model			P9	P9	P10	P11	P11	P11	P12
Available head (1PM)	(1)	kPa	201	201	201	201	201	201	201
Available head (2PM)	(1)	kPa	204	204	204	204	204	204	204
Pumps for glycol									
Pump model for high glycol			P10	P11	P12	P13	P14	P15	P15
Available head (1PG)	(1)	kPa	141	216	270	327	157	212	211
Available head (2PG)	(1)	kPa	114	206	256	310	136	184	196

			24.2	27.2	30.3	34.3	40.3	18.4	20.4
User-side hydraulic modules									
Volume of the expansion vessel		l	18	18	18	18	18	18	18
Volume of the buffer tank		l	270	270	400	400	400	270	270
Standard pumps									
Standard pump model			P14	P14	P14	P14	P15	P10	P10
Available head (1P)	(1)	kPa	147	131	126	102	126	134	114
Available head (2P)	(1)	kPa	159	147	136	115	142	149	124
Oversize pumps									
Oversize pump model			P15	P15	P15	P15	P16	P11	P11
Available head (1PM)	(1)	kPa	201	201	201	201	201	201	201
Available head (2PM)	(1)	kPa	204	204	204	204	204	204	204
Pumps for glycol									
Pump model for high glycol			P15	P15	P19	P19	P19	P14	P15
Available head (1PG)	(1)	kPa	189	168	199	185	178	169	228
Available head (2PG)	(1)	kPa	170	144	184	166	155	147	213

(1) Condensing temperature 50°C; user-side heat exchanger inlet-outlet water temperature 12/7°C. Values compliant with standard EN 14511

TETRIS W REV LC

			24.4	26.4	30.4	34.4	38.4
User-side hydraulic modules							
Volume of the expansion vessel		l	18	18	18	18	18
Volume of the buffer tank		l	270	270	400	400	400
Standard pumps							
Standard pump model			P14	P14	P14	P14	P14
Available head (1P)	(1)	kPa	163	150	158	144	106
Available head (2P)	(1)	kPa	176	167	167	155	121
Oversize pumps							
Oversize pump model			P15	P15	P15	P15	P16
Available head (1PM)	(1)	kPa	201	201	201	201	201
Available head (2PM)	(1)	kPa	204	204	204	204	204
Pumps for glycol							
Pump model for high glycol			P15	P15	P15	P19	P19
Available head (1PG)	(1)	kPa	212	195	188	229	201
Available head (2PG)	(1)	kPa	193	170	175	213	180

			40.4	48.4	54.4	56.6	60.6
User-side hydraulic modules							
Volume of the expansion vessel		l	18	25	25	25	25
Volume of the buffer tank		l	400	400	400	400	400
Standard pumps							
Standard pump model			P18	P18	P18	P18	P18
Available head (1P)	(1)	kPa	156	160	135	164	137
Available head (2P)	(1)	kPa	174	182	163	171	147
Oversize pumps							
Oversize pump model			P19	P19	P19	P19	P20
Available head (1PM)	(1)	kPa	201	201	201	201	201
Available head (2PM)	(1)	kPa	204	204	204	204	204
Pumps for glycol							
Pump model for high glycol			P19	P20	P23	P23	P23
Available head (1PG)	(1)	kPa	183	228	226	241	217
Available head (2PG)	(1)	kPa	157	195	185	229	202

(1) Condensing temperature 50°C; user-side heat exchanger inlet-outlet water temperature 12/7°C. Values compliant with standard EN 14511

TETRIS W REV LC/HP

			3.2	4.2	5.2	6.2	7.2	8.2	9.2
User-side hydraulic modules									
Volume of the expansion vessel		l	5	5	5	18	18	18	18
Volume of the buffer tank		l	200	200	200	200	200	200	200
Standard pumps									
Standard pump model			P1	P2	P4	P4	P4	P4	P7
Available head (1P)	(1)	kPa	117	154	159	156	144	127	129
Available head (2P)	(1)	kPa	120	158	163	162	151	137	141
Oversize pumps									
Oversize pump model			P3	P3	P5	P5	P5	P6	P8
Available head (1PM)	(1)	kPa	201	201	201	201	201	201	201
Available head (2PM)	(1)	kPa	204	204	204	204	204	204	204
Pumps for glycol									
Pump model for high glycol			P5	P5	P5	P5	P8	P8	P8
Available head (1PG)	(1)	kPa	205	199	191	189	181	167	155
Available head (2PG)	(1)	kPa	201	194	184	181	170	153	137

			10.2	12.2	13.2	15.2	17.2	19.2	20.2
User-side hydraulic modules									
Volume of the expansion vessel		l	18	18	18	18	18	18	18
Volume of the buffer tank		l	200	200	200	200	200	200	200
Standard pumps									
Standard pump model			P7	P8	P8	P10	P10	P10	P11
Available head (1P)	(1)	kPa	101	152	133	143	128	100	153
Available head (2P)	(1)	kPa	119	159	143	155	142	119	163
Oversize pumps									
Oversize pump model			P9	P9	P10	P11	P11	P11	P12
Available head (1PM)	(1)	kPa	201	201	201	201	201	201	201
Available head (2PM)	(1)	kPa	204	204	204	204	204	204	204
Pumps for glycol									
Pump model for high glycol			P10	P11	P12	P13	P14	P15	P15
Available head (1PG)	(1)	kPa	141	216	270	327	157	212	211
Available head (2PG)	(1)	kPa	114	206	256	310	136	184	196

(1) Condensing temperature 50°C; user-side heat exchanger inlet-outlet water temperature 12-7°C. Values compliant with standard EN 14511

TETRIS W REV LC/HP

			24.2	27.2	30.3	34.3	40.3	18.4	20.4
User-side hydraulic modules									
Volume of the expansion vessel		l	18	18	18	18	18	18	18
Volume of the buffer tank		l	270	270	400	400	400	270	270
Standard pumps									
Standard pump model			P14	P14	P14	P14	P15	P10	P10
Available head (1P)	(1)	kPa	147	131	126	102	126	134	114
Available head (2P)	(1)	kPa	159	147	136	115	142	149	124
Oversize pumps									
Oversize pump model			P15	P15	P15	P15	P16	P11	P11
Available head (1PM)	(1)	kPa	201	201	201	201	201	201	201
Available head (2PM)	(1)	kPa	204	204	204	204	204	204	204
Pumps for glycol									
Pump model for high glycol			P15	P15	P19	P19	P19	P14	P15
Available head (1PG)	(1)	kPa	189	168	199	185	178	169	228
Available head (2PG)	(1)	kPa	170	144	184	166	155	147	213

			24.4	26.4	30.4	34.4	38.4
User-side hydraulic modules							
Volume of the expansion vessel		l	18	18	18	18	18
Volume of the buffer tank		l	270	270	400	400	400
Standard pumps							
Standard pump model			P14	P14	P14	P14	P14
Available head (1P)	(1)	kPa	163	150	158	144	106
Available head (2P)	(1)	kPa	176	167	167	155	121
Oversize pumps							
Oversize pump model			P15	P15	P15	P15	P16
Available head (1PM)	(1)	kPa	201	201	201	201	201
Available head (2PM)	(1)	kPa	204	204	204	204	204
Pumps for glycol							
Pump model for high glycol			P15	P15	P15	P19	P19
Available head (1PG)	(1)	kPa	212	195	188	229	201
Available head (2PG)	(1)	kPa	193	170	175	213	180

			40.4	48.4	54.4	56.6	60.6
User-side hydraulic modules							
Volume of the expansion vessel		l	18	25	25	25	25
Volume of the buffer tank		l	400	400	400	400	400
Standard pumps							
Standard pump model			P18	P18	P18	P18	P18
Available head (1P)	(1)	kPa	156	160	135	164	137
Available head (2P)	(1)	kPa	174	182	163	171	147
Oversize pumps							
Oversize pump model			P19	P19	P19	P19	P20
Available head (1PM)	(1)	kPa	201	201	201	201	201
Available head (2PM)	(1)	kPa	204	204	204	204	204
Pumps for glycol							
Pump model for high glycol			P19	P20	P23	P23	P23
Available head (1PG)	(1)	kPa	183	228	226	241	217
Available head (2PG)	(1)	kPa	157	195	185	229	202

(1) Condensing temperature 50°C; user-side heat exchanger inlet-outlet water temperature 12-7°C. Values compliant with standard EN 14511

PUMP DATA

	Rated power	Rated current	Min. flow rate	Max. flow rate
	kW	A	m ³ /h	m ³ /h
P1	0,55	1,6	3,6	9,6
P2	0,9	2,1	3,6	9,6
P3	0,9	2,4	3,6	9,6
P4	1,1	2,5	7,0	18,0
P5	1,5	3,2	7,0	18,0
P6	1,85	4,2	7,0	18,0
P7	1,5	3,4	12,0	28,8
P8	1,85	4,5	12,0	31,2
P9	2,2	4,5	6,0	20,0
P10	2,2	4,5	12,0	42,0
P11	3,0	6,1	12,0	42,0
P12	4,0	8,7	12,0	42,0
P13	5,5	10,4	12,0	42,0
P14	4,0	8,7	24,0	72,0
P15	5,5	10,4	24,0	72,0
P16	7,5	13,7	24,0	72,0
P17	5,5	10,4	42,0	126,0
P18	7,5	13,6	42,0	132,0
P19	9,2	17,2	42,0	132,0
P20	11,0	21,3	42,0	138,0
P21	15,0	26,6	35,0	156,7
P22	11,0	20,2	58,0	237,0
P23	15,0	26,6	65,0	255,0

FLOW RATE RANGES OF HEAT EXCHANGERS

The units are sized and optimized for the following nominal conditions:

- inlet-outlet of the source-side heat exchanger 30/35°C
- inlet-outlet of the user-side heat exchanger 12/7°C

The units can work at design conditions different from nominal conditions, provided that:

- the design condition falls within the operating limits specified below
- the unit is equipped with all the accessories necessary for operation of the unit (e.g. brine kit, condensation control)
- the flow rate at design conditions (that is, of the specific application) must always come within the allowed flow rate ranges specified below. If the design conditions require a water flow rate that does not come within the allowed operating range, you must contact our sales department that will identify the most suitable solution for the specific application.

TETRIS W REV

	User-side heat exchanger		Source-side heat exchanger	
	Qmin	Qmax	Qmin	Qmax
	m ³ /h	m ³ /h	m ³ /h	m ³ /h
3.2	3,3	9,9	4,0	11,9
4.2	3,7	11,2	4,5	13,5
5.2	4,3	12,9	5,1	15,4
6.2	4,8	14,3	5,7	17,1
7.2	5,5	16,6	6,6	19,8
8.2	6,2	18,6	7,4	22,2
9.2	7,1	21,3	8,4	25,3
10.2	8,6	25,8	10,3	30,8
12.2	9,8	29,3	11,6	34,9
13.2	11,3	33,8	13,4	40,3
15.2	12,5	37,4	14,9	44,6
17.2	13,9	41,6	16,5	49,6
19.2	15,7	47,1	18,8	56,3
20.2	17,2	51,7	20,6	61,9
24.2	19,1	57,4	22,9	68,7
27.2	21,7	65,0	25,9	77,7
30.3	26,7	80,1	32,0	96,0
34.3	29,8	89,4	35,7	107,0
40.3	33,1	99,4	39,7	119,0
18.4	14,0	42,1	16,8	50,4
20.4	17,0	51,0	20,3	61,0
24.4	19,4	58,2	23,2	69,6
26.4	21,8	65,5	26,1	78,4
30.4	24,7	74,2	29,6	88,8
34.4	27,5	82,5	32,9	98,8
38.4	31,4	94,1	37,5	112,6
40.4	35,3	105,8	42,2	126,6
48.4	39,1	117,4	46,9	140,6
54.4	44,2	132,7	52,8	158,5
56.6	47,0	140,9	56,3	168,8
60.6	53,0	159,1	63,5	190,4

TETRIS W REV HP

	User-side heat exchanger		Source-side heat exchanger	
	Qmin	Qmax	Qmin	Qmax
	m ³ /h	m ³ /h	m ³ /h	m ³ /h
3.2	3,0	9,0	3,7	11,0
4.2	3,5	10,4	4,2	12,7
5.2	3,7	11,2	4,6	13,7
6.2	4,4	13,1	5,3	15,9
7.2	5,1	15,4	6,2	18,6
8.2	5,9	17,7	7,1	21,3
9.2	6,6	19,7	8,0	24,0
10.2	7,7	23,0	9,4	28,1
12.2	8,7	26,2	10,7	32,1
13.2	9,9	29,6	12,0	36,1
15.2	11,1	33,4	13,6	40,8
17.2	12,4	37,2	15,1	45,4
19.2	14,2	42,6	17,3	52,0
20.2	16,0	47,9	19,5	58,5
24.2	17,7	53,2	21,7	65,1
27.2	20,4	61,2	24,8	74,3
30.3	24,4	73,2	29,6	88,9
34.3	26,8	80,4	32,6	97,9
40.3	30,1	90,3	36,6	109,8
18.4	13,0	39,1	15,8	47,5
20.4	15,5	46,4	18,9	56,6
24.4	17,6	52,8	21,4	64,3
26.4	19,8	59,5	24,1	72,4
30.4	23,2	69,5	28,0	83,9
34.4	24,1	72,4	29,6	88,9
38.4	28,3	84,9	34,5	103,5
40.4	31,4	94,3	38,5	115,5
48.4	35,3	106,0	43,3	129,9
54.4	40,1	120,4	49,0	147,0
56.6	42,4	127,2	51,8	155,3
60.6	47,2	141,7	57,7	173,1

TETRIS W REV OH

	User-side heat exchanger		Source-side heat exchanger	
	Qmin	Qmax	Qmin	Qmax
	m ³ /h	m ³ /h	m ³ /h	m ³ /h
3.2	3,6	10,8	2,8	8,3
4.2	4,1	12,3	3,2	9,5
5.2	4,5	13,4	3,5	10,4
6.2	5,2	15,6	4,1	12,2
7.2	6,0	17,9	4,6	13,8
8.2	6,7	20,0	5,1	15,4
9.2	7,6	22,8	5,9	17,7
10.2	9,2	27,6	7,1	21,4
12.2	10,4	31,2	8,1	24,2
13.2	11,7	35,0	9,1	27,2
15.2	13,3	40,0	10,4	31,2
17.2	14,8	44,5	11,5	34,6
19.2	16,8	50,4	13,1	39,2
20.2	18,5	55,5	14,3	42,9
24.2	20,7	62,0	15,9	47,7
27.2	23,3	69,8	18,0	53,9
30.3	29,0	87,1	22,6	67,9
34.3	33,0	99,1	25,6	76,9
40.3	36,7	110,1	28,6	85,7
18.4	15,1	45,2	11,7	35,1
20.4	18,2	54,7	14,2	42,6
24.4	20,8	62,3	16,2	48,5
26.4	23,3	69,9	18,1	54,4
30.4	26,5	79,5	20,6	61,9
34.4	29,7	89,0	23,1	69,4
38.4	33,7	101,2	26,2	78,7
40.4	37,9	113,7	29,5	88,5
48.4	42,5	127,5	32,7	98,0
54.4	47,5	142,4	36,7	110,2
56.6	50,7	152,0	39,4	118,2
60.6	57,0	171,1	44,4	133,1

TETRIS W REV HPW

	Evaporator		Condenser	
	Qmin	Qmax	Qmin	Qmax
	m ³ /h	m ³ /h	m ³ /h	m ³ /h
3.2	3,3	9,9	4,0	11,9
4.2	3,7	11,2	4,5	13,5
5.2	4,3	12,9	5,1	15,4
6.2	4,8	14,3	5,7	17,1
7.2	5,5	16,6	6,6	19,8
8.2	6,2	18,6	7,4	22,2
9.2	7,1	21,3	8,4	25,3
10.2	8,6	25,8	10,3	30,8
12.2	9,8	29,3	11,6	34,9
13.2	11,3	33,8	13,4	40,3
15.2	12,5	37,4	14,9	44,6
17.2	13,9	41,6	16,5	49,6
19.2	15,7	47,1	18,8	56,3
20.2	17,2	51,7	20,6	61,9
24.2	19,1	57,4	22,9	68,7
27.2	21,7	65,0	25,9	77,7
30.3	26,7	80,1	32,0	96,0
34.3	29,8	89,4	35,7	107,0
40.3	33,1	99,4	39,7	119,0
18.4	14,0	42,1	16,8	50,4
20.4	17,0	51,0	20,3	61,0
24.4	19,4	58,2	23,2	69,6
26.4	21,8	65,5	26,1	78,4
30.4	24,7	74,2	29,6	88,8
34.4	27,5	82,5	32,9	98,8
38.4	31,4	94,1	37,5	112,6
40.4	35,3	105,8	42,2	126,6
48.4	39,1	117,4	46,9	140,6
54.4	44,2	132,7	52,8	158,5
56.6	47,0	140,9	56,3	168,8
60.6	53,0	159,1	63,5	190,4

TETRIS W REV LC

	User-side heat exchanger	
	Qmin	Qmax
	m ³ /h	m ³ /h
3.2	2,8	8,5
4.2	3,2	9,7
5.2	3,5	10,6
6.2	4,1	12,4
7.2	4,7	14,2
8.2	5,3	15,9
9.2	6,1	18,3
10.2	7,4	22,2
12.2	8,4	25,3
13.2	9,5	28,4
15.2	10,8	32,3
17.2	12,0	35,9
19.2	13,6	40,8
20.2	14,8	44,4
24.2	16,3	49,0
27.2	18,4	55,2
30.3	23,8	71,5
34.3	26,9	80,8
40.3	29,8	89,5
18.4	12,2	36,6
20.4	14,8	44,4
24.4	16,8	50,3
26.4	18,9	56,8
30.4	21,5	64,5
34.4	24,0	72,0
38.4	27,6	82,8
40.4	30,8	92,4
48.4	33,7	101,1
54.4	37,8	113,5
56.6	40,8	122,3
60.6	45,9	137,8

TETRIS W REV LC/HP

	User-side heat exchanger	
	Qmin	Qmax
	m ³ /h	m ³ /h
3.2	3,0	9,1
4.2	3,5	10,5
5.2	3,8	11,4
6.2	4,4	13,3
7.2	5,2	15,6
8.2	5,9	17,7
9.2	6,6	19,7
10.2	7,7	23,0
12.2	8,8	26,4
13.2	9,9	29,7
15.2	11,2	33,5
17.2	12,4	37,2
19.2	14,2	42,6
20.2	16,0	48,0
24.2	17,7	53,2
27.2	20,4	61,2
30.3	24,4	73,2
34.3	26,8	80,4
40.3	30,1	90,3
18.4	13,0	39,1
20.4	15,5	46,4
24.4	17,6	52,8
26.4	19,8	59,5
30.4	23,2	69,5
34.4	24,1	72,4
38.4	28,3	84,9
40.4	31,4	94,3
48.4	35,3	106,0
54.4	40,1	120,4
56.6	42,4	127,3
60.6	47,2	141,7

OPERATING LIMITS

Tetris W Rev - Tetris W Rev HP - Tetris W Rev OH - Tetris W Rev HPW

COOLING

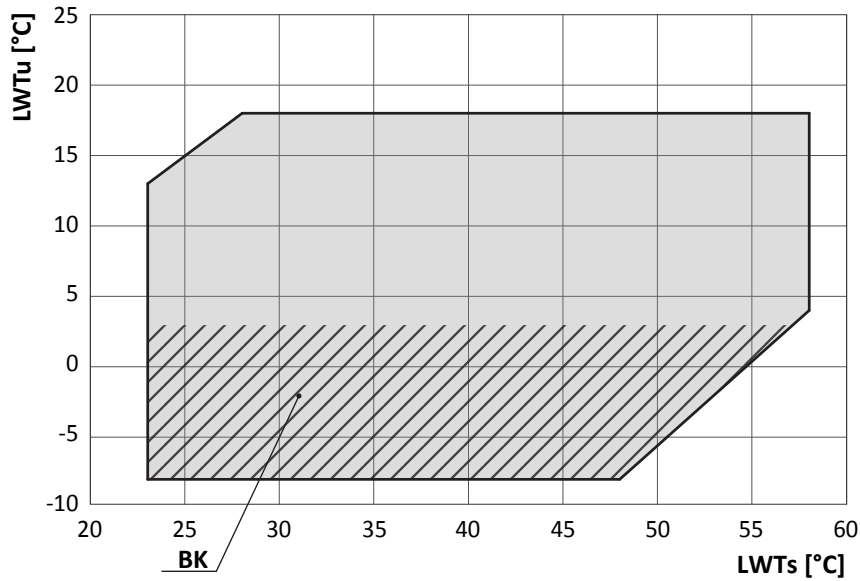

HEATING

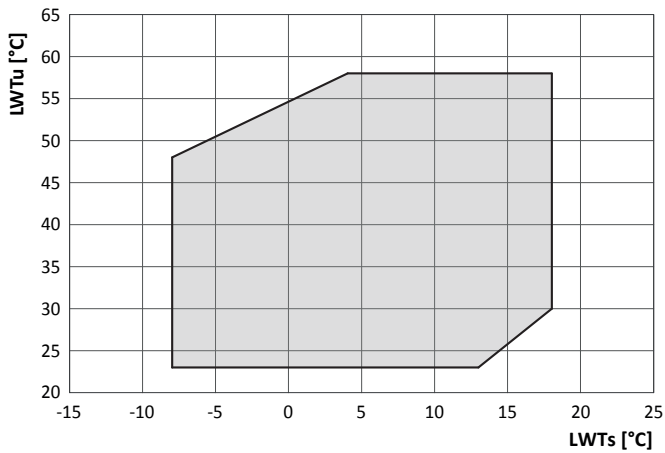

TOTAL RECOVERY

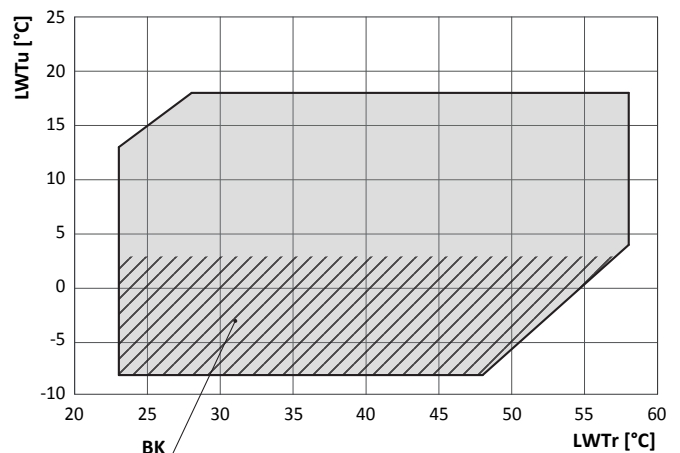

- LWTs:** water outlet temperature from the source-side heat exchanger
- LWTu:** water outlet temperature from the user-side heat exchanger
- LWTr:** water outlet temperature from the recovery exchanger
- BK:** For LWTu below +3°C, it is mandatory to fit the "Brine Kit" accessory

For LWTu below +5°C, it is compulsory to use suitable percentages of antifreeze additives (glycols) to prevent ice formation in the exchanger.

For LWTs below +5°C, it is compulsory to use suitable percentages of antifreeze additives (glycols) to prevent ice formation in the heat exchanger.

The inlet and outlet temperatures of the user-side exchanger must be given on ordering to allow correct setting of the alarm parameters and verification of the sizing of the expansion valve.

The cooling set point can then be changed by the customer in an interval that, compared to the set point given on ordering, ranges from -1K up to the maximum temperature allowed by the above-stated operating limits.

The unit will be optimized to work at the set point temperatures given on ordering. For different set points, the cooling capacity provided and the level of efficiency of the machine could decrease and move away from these conditions.

Tetris W Rev LC - Tetris W Rev LC/HP

COOLING

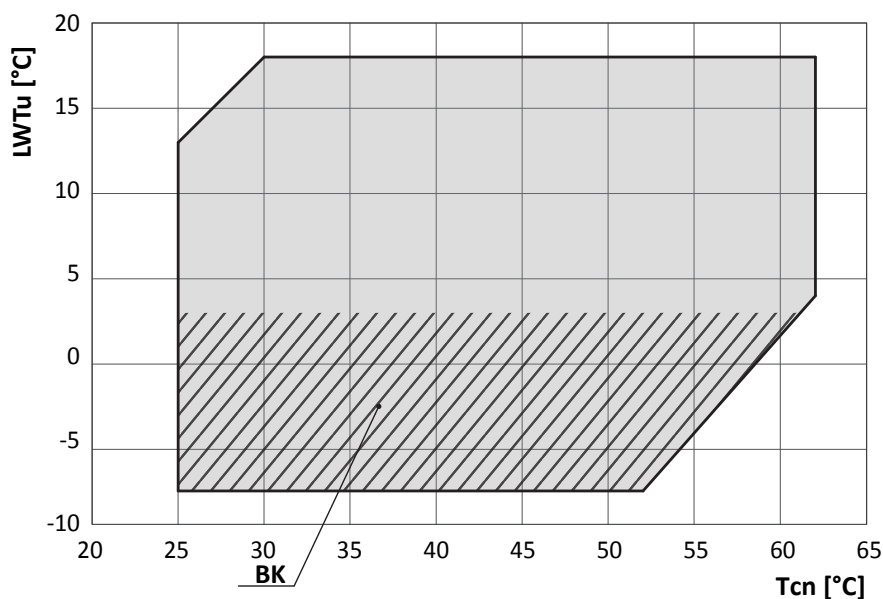

HEATING

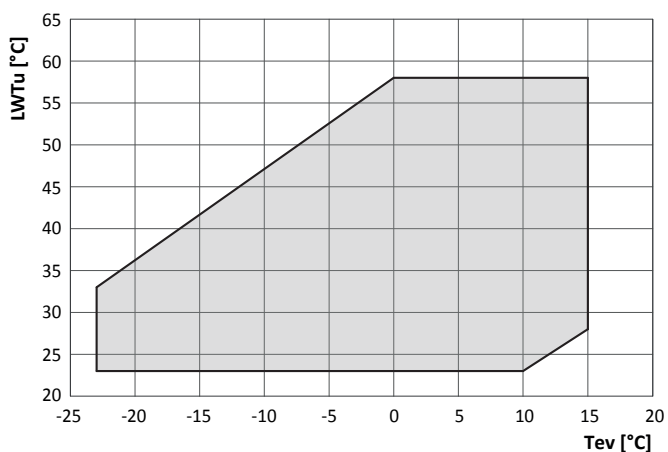

TOTAL RECOVERY

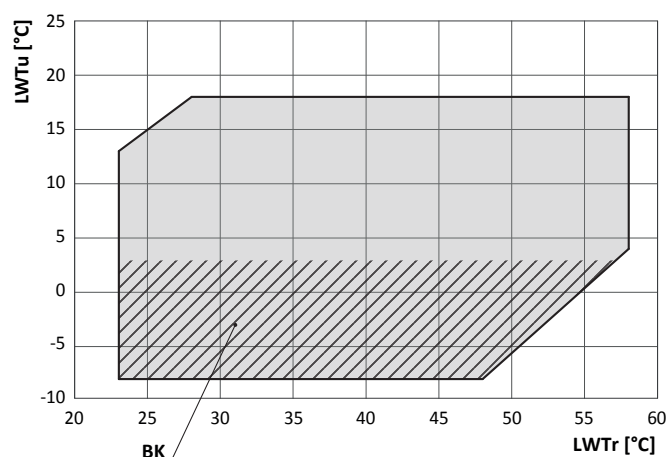

- Tev:** evaporating temperature
- Tcn:** condensing temperature
- LWTu:** water outlet temperature from the user-side heat exchanger
- LWTr:** water outlet temperature from the recovery exchanger
- BK:** For LWTu below +3°C, it is mandatory to fit the "Brine Kit" accessory

For LWTu below +5°C, it is compulsory to use suitable percentages of antifreeze additives (glycols) to prevent ice formation in the exchanger.

The inlet and outlet temperatures of the user-side exchanger must be given on ordering to allow correct setting of the alarm parameters and verification of the sizing of the expansion valve.

The cooling set point can then be changed by the customer in an interval that, compared to the set point given on ordering, ranges from -1K up to the maximum temperature allowed by the above-stated operating limits.

The unit will be optimized to work at the set point temperatures given on ordering. For different set points, the cooling capacity provided and the level of efficiency of the machine could decrease and move away from these conditions.

NOISE LEVELS

TETRIS W REV

v	Octave bands [dB]																Total [dB(A)]	
	63 Hz		125 Hz		250 Hz		500 Hz		1000 Hz		2000 Hz		4000 Hz		8000 Hz		Lw_tot	Lp_tot
	Lw	Lp	Lw	Lp	Lw	Lp	Lw	Lp	Lw	Lp	Lw	Lp	Lw	Lp	Lw	Lp		
3.2	30	14	22	10	39	24	57	42	64	49	65	50	68	53	65	49	73	57
4.2	30	14	22	10	44	29	64	49	72	56	67	51	68	52	60	44	75	59
5.2	34	18	24	10	49	33	68	52	69	54	70	55	67	52	56	41	75	60
6.2	35	19	26	11	50	34	70	54	70	55	73	58	69	54	58	43	77	62
7.2	35	20	21	10	49	33	70	54	72	56	72	57	69	54	59	43	77	62
8.2	37	21	28	12	47	31	65	49	73	57	74	59	70	54	62	47	78	63
9.2	41	25	31	16	50	34	68	53	72	56	75	60	71	56	60	44	79	63
10.2	39	24	32	17	46	30	69	54	72	57	76	61	74	58	64	48	80	65
12.2	40	24	33	17	47	31	72	55	75	59	79	63	76	60	66	49	83	66
13.2	37	21	35	18	61	44	70	53	70	54	82	66	72	56	55	38	84	67
15.2	38	21	35	19	61	45	71	54	71	55	83	67	73	56	56	39	85	69
17.2	36	19	30	14	59	43	69	52	77	61	82	66	75	58	64	47	85	69
19.2	36	20	30	14	60	44	70	53	78	62	83	67	76	59	64	48	86	70
20.2	38	22	30	14	65	49	75	59	80	64	84	67	78	61	63	46	87	71
24.2	38	22	30	14	65	49	75	59	80	64	84	67	78	61	63	46	87	71
27.2	38	22	30	14	62	45	68	52	83	66	84	68	75	59	62	45	88	71
30.3	39	22	31	14	66	49	76	59	81	64	85	68	78	61	64	47	88	71
34.3	39	22	31	14	66	49	76	59	81	64	85	68	78	61	64	47	88	71
40.3	39	22	31	14	63	46	70	53	85	68	87	70	78	61	63	46	90	73
18.4	43	26	33	16	52	35	71	54	75	58	78	61	75	58	63	46	82	65
20.4	40	23	33	16	47	30	72	55	75	58	79	62	76	59	66	49	83	66
24.4	42	25	35	17	49	32	75	57	78	61	82	65	79	62	69	51	86	69
26.4	39	21	36	19	63	45	72	55	73	55	85	68	75	57	57	39	87	69
30.4	39	21	37	19	64	46	73	56	74	56	86	69	76	58	58	40	88	71
34.4	37	20	31	14	62	44	71	54	80	62	85	68	77	60	66	48	88	71
38.4	38	20	32	14	62	45	72	55	81	63	86	69	78	61	67	49	89	72
40.4	40	22	31	14	68	50	78	60	83	65	87	69	80	63	65	48	90	72
48.4	40	22	31	14	68	50	78	60	83	65	87	69	80	63	65	48	90	73
54.4	40	22	31	14	64	47	71	53	86	68	88	70	78	61	64	46	91	73
56.6	39	21	32	14	64	46	74	56	83	65	88	70	80	62	68	50	91	73
60.6	40	22	32	14	68	50	79	61	84	66	88	70	81	63	66	48	91	73

Reference conditions: source-side heat exchanger inlet-outlet temperature 30/35°C; user side heat exchanger inlet/outlet water temperature 12/7°C. Unit operating at nominal operating capacity, without any accessories.

Lw: sound power levels. Lw_tot is the only binding value. Values obtained from measures taken according to standard ISO 3744.
Lp: sound pressure levels calculated from sound power levels, related to distance of 1m from the unit in free field with directivity factor Q=2. Non-binding values.

TETRIS W REV /LN

v	Octave bands [dB]																Total [dB(A)]	
	63 Hz		125 Hz		250 Hz		500 Hz		1000 Hz		2000 Hz		4000 Hz		8000 Hz		Lw_tot	Lp_tot
	Lw	Lp	Lw	Lp	Lw	Lp	Lw	Lp	Lw	Lp	Lw	Lp	Lw	Lp	Lw	Lp		
3.2	27	11	20	10	36	20	52	36	58	42	59	43	62	46	58	43	66	50
4.2	27	12	19	10	40	25	58	43	65	49	60	45	61	46	54	38	68	52
5.2	30	15	22	10	44	28	61	45	62	47	63	48	60	45	50	35	68	53
6.2	31	16	23	10	44	29	63	47	63	48	66	50	62	47	52	37	70	55
7.2	32	16	18	10	44	28	63	47	64	49	65	49	62	47	53	37	70	55
8.2	33	18	25	10	42	26	58	43	65	50	67	51	62	47	56	41	71	56
9.2	37	21	28	13	45	30	62	46	65	49	68	52	65	49	54	39	72	56
10.2	35	20	29	14	41	26	63	47	65	50	69	53	66	51	57	42	73	58
12.2	37	20	30	14	43	27	65	49	68	52	72	55	69	53	60	43	76	59
13.2	34	17	32	15	55	39	64	47	64	48	75	58	66	49	50	34	77	60
15.2	34	18	32	16	56	40	64	48	65	49	76	60	67	50	51	34	78	62
17.2	33	16	27	11	54	38	63	46	70	54	75	59	68	52	58	42	78	62
19.2	33	17	28	11	55	38	64	47	71	55	76	60	69	53	59	42	79	63
20.2	35	18	28	11	60	43	69	52	73	57	77	60	71	54	57	41	80	64
24.2	35	18	28	11	60	43	69	52	73	57	77	60	71	54	57	41	80	64
27.2	35	19	28	11	57	40	63	46	76	59	78	61	69	53	57	40	81	64
30.3	35	18	28	11	60	43	70	53	74	57	78	61	72	55	58	41	81	64
34.3	35	18	28	11	60	43	70	53	74	57	78	61	72	55	58	41	81	64
40.3	36	19	28	11	58	41	64	47	78	61	80	63	71	54	58	41	83	66
18.4	39	22	30	13	47	30	65	48	68	51	71	54	68	51	57	40	75	58
20.4	37	20	30	13	43	26	65	48	68	51	72	55	69	52	60	43	76	59
24.4	38	21	32	14	45	28	68	51	71	54	75	57	72	55	62	45	79	62
26.4	35	18	33	16	58	40	66	49	67	49	78	61	68	51	52	35	80	62
30.4	36	18	34	16	58	41	67	50	68	50	79	62	69	52	53	35	81	64
34.4	34	17	29	11	56	39	65	48	73	56	78	61	71	53	60	43	81	64
38.4	35	17	29	11	57	40	66	49	74	57	79	62	72	54	61	44	82	65
40.4	36	19	29	11	62	45	71	54	76	59	80	62	74	56	60	42	83	65
48.4	36	19	29	11	62	45	71	54	76	59	80	62	74	56	60	42	83	66
54.4	37	19	29	11	59	41	65	48	79	61	81	63	72	55	59	41	84	66
56.6	35	17	30	12	59	41	68	50	76	58	81	63	74	56	63	45	84	66
60.6	37	19	29	11	63	45	72	54	77	59	81	63	75	57	60	42	84	66

Reference conditions: source-side heat exchanger inlet-outlet temperature 30/35°C; user side heat exchanger inlet/outlet water temperature 12/7°C. Unit operating at nominal operating capacity, without any accessories.

Lw: sound power levels. Lw_tot is the only binding value. Values obtained from measures taken according to standard ISO 3744.
Lp: sound pressure levels calculated from sound power levels, related to distance of 1m from the unit in free field with directivity factor Q=2. Non-binding values.

CONFIGURATIONS THAT ARE NOT POSSIBLE

The high number of configurations and options available for the Tetris W Rev range requires such a high number of dimensional drawings that it is not practical to insert them all in this document.

We suggest you contact our sales department that will help you identify the most suitable model and configuration for your requirements, and provide you with all the necessary information and updated dimensional drawings.

On the following pages, you will find some tables on the configurations available in the catalogue and the dimensions of the units in various set-ups to enable you to make an initial assessment of the overall dimensions.

TETRIS W REV

	/1P /1S	/1S /1R	/1P /1R	/1P /1S /1R	/2P /2S	/2S /2R	/2P /2R	/1P /2S	/2P /1S	/2P /1S /1R	/1PS /1S	/1PS /1R	/1PS /1S /1R	/2PS /2S	/2PS /2R	/1PS /2S	/2PS /1S	/2PS /1S /1R
3.2																		
4.2																		
5.2																		
6.2																		
7.2																		
8.2																		
9.2																		
10.2																		
12.2						n.a.							n.a.	n.a.	n.a.	n.a.	n.a.	n.a.
13.2						n.a.							n.a.	n.a.	n.a.	n.a.	n.a.	n.a.
15.2						n.a.							n.a.	n.a.	n.a.	n.a.	n.a.	n.a.
17.2						n.a.							n.a.	n.a.	n.a.	n.a.	n.a.	n.a.
19.2						n.a.							n.a.	n.a.	n.a.	n.a.	n.a.	n.a.
20.2						n.a.							n.a.	n.a.	n.a.	n.a.	n.a.	n.a.
24.2											n.a.	n.a.	n.a.	n.a.	n.a.	n.a.	n.a.	n.a.
27.2											n.a.	n.a.	n.a.	n.a.	n.a.	n.a.	n.a.	n.a.
30.3						n.a.					n.a.	n.a.	n.a.	n.a.	n.a.	n.a.	n.a.	n.a.
34.3						n.a.					n.a.	n.a.	n.a.	n.a.	n.a.	n.a.	n.a.	n.a.
40.3						n.a.					n.a.	n.a.	n.a.	n.a.	n.a.	n.a.	n.a.	n.a.
18.4											n.a.	n.a.	n.a.	n.a.	n.a.	n.a.	n.a.	n.a.
20.4											n.a.	n.a.	n.a.	n.a.	n.a.	n.a.	n.a.	n.a.
24.4											n.a.	n.a.	n.a.	n.a.	n.a.	n.a.	n.a.	n.a.
26.4											n.a.	n.a.	n.a.	n.a.	n.a.	n.a.	n.a.	n.a.
30.4											n.a.	n.a.	n.a.	n.a.	n.a.	n.a.	n.a.	n.a.
34.4											n.a.	n.a.	n.a.	n.a.	n.a.	n.a.	n.a.	n.a.
38.4											n.a.	n.a.	n.a.	n.a.	n.a.	n.a.	n.a.	n.a.
40.4											n.a.	n.a.	n.a.	n.a.	n.a.	n.a.	n.a.	n.a.
48.4											n.a.	n.a.	n.a.	n.a.	n.a.	n.a.	n.a.	n.a.
54.4											n.a.	n.a.	n.a.	n.a.	n.a.	n.a.	n.a.	n.a.
56.6											n.a.	n.a.	n.a.	n.a.	n.a.	n.a.	n.a.	n.a.
60.6											n.a.	n.a.	n.a.	n.a.	n.a.	n.a.	n.a.	n.a.

n.a.: configuration not available

TABLES OF DIMENSIONS

Units without hydraulic modules

	BASE - OH - HPW	/DS	/DC	HP	HP /DS	LC	LC /DC	LC/HP	LC/HP /DS
3.2	2A	2A	2A	2A	2A	2A	2A	2A	2A
4.2	2A	2A	2A	2A	2A	2A	2A	2A	2A
5.2	2A	2A	2A	2A	2A	2A	2A	2A	2A
6.2	2A	2A	2A	2A	2A	2A	2A	2B	2B
7.2	2A	2A	2A	2A	2A	2A	2A	2B	2B
8.2	2A	2A	2A	2A	2A	2A	2A	2B	2B
9.2	2A	2A	2A	2A	2A	2A	2A	2B	2B
10.2	2A	2A	2A	2A	2A	2A	2A	2B	2B
12.2	2B	2B	2B	2B	2B	2B	2B	2B	2B
13.2	2B	2B	2B	2B	2B	2B	2B	2B	2B
15.2	2B	2B	2B	2B	2B	2B	2B	2B	2B
17.2	2B	2B	2B	2B	2B	2B	2B	2B	2B
19.2	2B	2B	2B	2B	2B	2B	2B	2B	2B
20.2	2B	2B	2B	2B	2B	2B	2B	2B	2B
24.2	2B	2B	3A	3A	3A	2B	3A	3A	3A
27.2	2B	2B	3A	3A	3A	2B	3A	3A	3A
30.3	3A	4A	4A	3A	4A	3A	4A	3A	4A
34.3	3A	4A	4A	3A	4A	3A	4A	3A	4A
40.3	3A	4A	4A	3A	4A	3A	4A	3A	4A
18.4	3A	3A	3A	3A	3A	3A	3A	3A	3A
20.4	3A	3A	3A	3A	3A	3A	3A	3A	3A
24.4	4A	4A	4A	4A	4A	4A	4A	4A	4A
26.4	4A	4A	4A	4A	4A	4A	4A	4A	4A
30.4	4A	4A	4A	4A	4A	4A	4A	4A	4A
34.4	4A	4A	4A	4A	4A	4A	4A	4A	4A
38.4	4A	4A	4A	4A	4A	4A	4A	4A	4A
40.4	4A	4A	4A	4A	4A	4A	4A	4A	4A
48.4	4A	4A	4A	4A	4A	4A	4A	4A	4A
54.4	4A	4A	4A	4A	4A	4A	4A	4A	4A
56.6	6A	6A	6A	6A	6A	6A	6A	6A	n.a.
60.6	6A	6A	6A	6A	6A	6A	6A	6A	n.a.

n.a.: configuration not available

Legenda

	Length	Depth	Height
2A	1633	792	967
2B	1633	792	1880
2C	2917	792	1880
3A	2017	872	1880
3B	3685	872	1880
3C	3301	872	1880
4A	2834	872	1880
4B	4502	872	1880
6A	3334	872	1880
6B	5002	872	1880

Units with hydraulic modules, without tank

	BASE - OH - HPW	/DS	/DC	HP	HP /DS	LC	LC /DC	LC/HP	LC/HP /DS
3.2	2B	2B	2B	2B	2B	2B	2B	2B	2B
4.2	2B	2B	2B	2B	2B	2B	2B	2B	2B
5.2	2B	2B	2B	2B	2B	2B	2B	2B	2B
6.2	2B	2B	2B	2B	2B	2B	2B	2B	2B
7.2	2B	2B	2B	2B	2B	2B	2B	2B	2B
8.2	2B	2B	2B	2B	2B	2B	2B	2B	2B
9.2	2B	2B	2B	2B	2B	2B	2B	2B	2B
10.2	2B	2B	2B	2B	2B	2B	2B	2B	2B
12.2	2C	2C	2C	2C	2C	2C	2C	2C	2C
13.2	2C	2C	2C	2C	2C	2C	2C	2C	2C
15.2	2C	2C	2C	2C	2C	2C	2C	2C	2C
17.2	2C	2C	2C	2C	2C	2C	2C	2C	2C
19.2	2C	2C	2C	2C	2C	2C	2C	2C	2C
20.2	2C	2C	2C	2C	2C	2C	2C	2C	2C
24.2	2C	2C	3C	3C	3C	2C	3C	3C	3C
27.2	2C	2C	3C	3C	3C	2C	3C	3C	3C
30.3	3B	4B	4B	3B	4B	3B	4B	3B	4B
34.3	3B	4B	4B	3B	4B	3B	4B	3B	4B
40.3	3B	4B	4B	3B	4B	3B	4B	3B	4B
18.4	3C	3C	3C	3C	3C	3C	3C	3C	3C
20.4	3C	3C	3C	3C	3C	3C	3C	3C	3C
24.4	4B	4B	4B	4B	4B	4B	4B	4B	4B
26.4	4B	4B	4B	4B	4B	4B	4B	4B	4B
30.4	4B	4B	4B	4B	4B	4B	4B	4B	4B
34.4	4B	4B	4B	4B	4B	4B	4B	4B	4B
38.4	4B	4B	4B	4B	4B	4B	4B	4B	4B
40.4	4B	4B	4B	4B	4B	4B	4B	4B	4B
48.4	4B	4B	4B	4B	4B	4B	4B	4B	4B
54.4	4B	4B	4B	4B	4B	4B	4B	4B	4B
56.6	6B	6B	6B	6B	6B	6B	6B	6B	n.a.
60.6	6B	6B	6B	6B	6B	6B	6B	6B	n.a.

n.a.: configuration not available

Legenda

	Length	Depth	Height
2A	1633	792	967
2B	1633	792	1880
2C	2917	792	1880
3A	2017	872	1880
3B	3685	872	1880
3C	3301	872	1880
4A	2834	872	1880
4B	4502	872	1880
6A	3334	872	1880
6B	5002	872	1880

Units with hydraulic modules and with tank

	BASE - OH - HPW	/DS	/DC	HP	HP /DS	LC	LC /DC	LC/HP	LC/HP /DS
3.2	2C	2C	2C	2C	2C	2C	2C	2C	2C
4.2	2C	2C	2C	2C	2C	2C	2C	2C	2C
5.2	2C	2C	2C	2C	2C	2C	2C	2C	2C
6.2	2C	2C	2C	2C	2C	2C	2C	2C	2C
7.2	2C	2C	2C	2C	2C	2C	2C	2C	2C
8.2	2C	2C	2C	2C	2C	2C	2C	2C	2C
9.2	2C	2C	2C	2C	2C	2C	2C	2C	2C
10.2	2C	2C	2C	2C	2C	2C	2C	2C	2C
12.2	2C	2C	2C	2C	2C	2C	2C	2C	2C
13.2	2C	2C	2C	2C	2C	2C	2C	2C	2C
15.2	2C	2C	2C	2C	2C	2C	2C	2C	2C
17.2	2C	2C	2C	2C	2C	2C	2C	2C	2C
19.2	2C	2C	2C	2C	2C	2C	2C	2C	2C
20.2	2C	2C	2C	2C	2C	2C	2C	2C	2C
24.2	2C	2C	3C	3C	3C	2C	3C	3C	3C
27.2	2C	2C	3C	3C	3C	2C	3C	3C	3C
30.3	3B	n.a.	n.a.	3B	n.a.	3B	n.a.	3B	n.a.
34.3	3B	n.a.	n.a.	3B	n.a.	3B	n.a.	3B	n.a.
40.3	3B	n.a.	n.a.	3B	n.a.	3B	n.a.	3B	n.a.
18.4	3C	3C	3C	3C	3C	3C	3C	3C	3C
20.4	3C	3C	3C	3C	3C	3C	3C	3C	3C
24.4	4B	4B	4B	4B	4B	4B	4B	4B	4B
26.4	4B	4B	4B	4B	4B	4B	4B	4B	4B
30.4	4B	4B	4B	4B	4B	4B	4B	4B	4B
34.4	4B	4B	4B	4B	4B	4B	4B	4B	4B
38.4	4B	4B	4B	4B	4B	4B	4B	4B	4B
40.4	4B	4B	4B	4B	4B	4B	4B	4B	4B
48.4	4B	4B	4B	4B	4B	4B	4B	4B	4B
54.4	4B	4B	4B	4B	4B	4B	4B	4B	4B
56.6	6B	6B	6B	6B	6B	6B	6B	6B	n.a.
60.6	6B	6B	6B	6B	6B	6B	6B	6B	n.a.

n.a.: configuration not available

Legenda

	Length	Depth	Height
2A	1633	792	967
2B	1633	792	1880
2C	2917	792	1880
3A	2017	872	1880
3B	3685	872	1880
3C	3301	872	1880
4A	2834	872	1880
4B	4502	872	1880
6A	3334	872	1880
6B	5002	872	1880

INSTALLATION ADVICE

The units described in this document are, by nature, strongly affected by the characteristics of the system, the working conditions and the installation site.

Remember that the unit must be installed by a qualified and skilled technician, and in compliance with the national legislation in force in the destination country.

The installation must be done in such a way that it will be possible to carry out all routine and non-routine maintenance operations.

Before starting any work, you must carefully read the "Installation, operation and maintenance manual" of the machine and do the necessary safety checks to prevent any malfunctioning or hazards.

We give some advice below that will allow you to increase the efficiency and reliability of the unit and therefore of the system into which it is inserted.

Water characteristics

To preserve the life of the exchangers, the water is required to comply with some quality parameters and it is therefore necessary to make sure its values fall within the ranges indicated in the following table:

Total hardness	2,0 ÷ 6,0 °f
Langelier index	- 0,4 ÷ 0,4
pH	7,5 ÷ 8,5
Electrical conductivity	10 ÷ 500 µS/cm
Organic elements	-
Hydrogen carbonate (HCO₃⁻)	70 ÷ 300 ppm
Sulphates (SO₄²⁻)	< 50 ppm
Hydrogen carbonate / Sulphates (HCO₃⁻/SO₄²⁻)	> 1
Chlorides (Cl⁻)	< 50 ppm
Nitrates (NO₃⁻)	< 50 ppm
Hydrogen sulphide (H₂S)	< 0,05 ppm
Ammonia (NH₃)	< 0,05 ppm
Sulphites (SO₃⁻), free chlorine (Cl₂)	< 1 ppm
Carbon dioxide (CO₂)	< 5 ppm
Metal cations	< 0,2 ppm
Manganese ions (Mn⁺⁺)	< 0,2 ppm
Iron ions (Fe²⁺, Fe³⁺)	< 0,2 ppm
Iron + Manganese	< 0,4 ppm
Phosphates (PO₄³⁻)	< 2 ppm
Oxygen	< 0,1 ppm

Installation of water filters on all the hydraulic circuits is obligatory.

The supply of the most suitable filters for the unit can be requested as accessory. In this case, the filters are supplied loose and must be installed by the customer following the instructions given in the installation, operation and maintenance manual.

Glycol mixtures

With temperatures below 5°C, it is mandatory to work with water and anti-freeze mixtures, and also change the safety devices (anti-freeze, etc.), which must be carried out by qualified authorised personnel or by the manufacturer.

Liquid outlet temperature or minimum ambient temperature	°C	0	-5	-10	-15	-20	-25	-30	-35	-40
Freezing point	°C	-5	-10	-15	-20	-25	-30	-35	-40	-45
Ethylene glycol	%	6	22	30	36	41	46	50	53	56
Propylene glycol	%	15	25	33	39	44	48	51	54	57

The quantity of antifreeze should be considered as % on weight

Minimum water content in the system

For correct operation of the unit, it is necessary to ensure a buffering on the system such as to comply with the minimum operating time considering the greater between the minimum OFF time and the minimum ON time. In short, these contribute to limiting the number of times the compressors are switched on per hour and to preventing undesired deviations from the set point of the delivered water temperature.

The following experimental formula allows the minimum water volume of the system to be calculated:

$$V_{min} = \frac{P_{tot} \cdot 1.000}{N} \cdot \frac{300}{\Delta T \cdot \rho \cdot c_p} + P_{tot} \cdot 0,25$$

where

V_{min} is the minimum water content of the system measured in l

P_{tot} is the total cooling capacity of the machine measured in kW

N is the number of capacity reduction steps

ΔT is the differential allowed on the water temperature. Unless otherwise specified, this value is considered to be 2.5K

ρ is the density of the heat-carrying fluid. Unless otherwise specified, the density of water is considered and therefore 1000kg/m³

c_p is the specific heat of the heat-carrying fluid. Unless otherwise specified, the specific heat of water is considered and therefore 4.186kJ/(kgK)

Considering the use of water and grouping together some terms, the formula can be re-written as follows:

$$V_{min} = \frac{P_{tot}}{N} \cdot 17,2 + P_{tot} \cdot 0,25$$

N is equal to the number of compressors installed in the unit.

Installation site

To determine the best installation site for the unit and its orientation, you should pay attention to the following points:

- compliance with the clearance spaces indicated in the official dimensional drawing of the unit must be guaranteed so as to ensure accessibility for routine and non-routine maintenance operations
- you should consider the origin of the hydraulic pipes and their diameters because these affect the radiuses of curvature and therefore the spaces needed for installing them
- you should consider the position of the cable inlet on the electrical control panel of the unit as regards the origin of the power supply
- if the installation includes several units side by side, you should consider the position and dimensions of the manifolds of the heat exchangers

Once the best position for the unit has been identified, you must check that the support slab has the following characteristics:

- its dimensions must be proportionate to those of the unit: if possible, longer and wider than the unit by at least 30 cm and 15/20cm higher than the surrounding surface
- it must be able to bear at least 4 times the operating weight of the unit
- must allow the unit to be installed in a level position

The units are designed and built to reduce to a minimum the level of vibration transmitted to the ground, but it is in any case advisable to use rubber or spring anti-vibration mounts, which are available as accessory and should be requested when ordering.

The anti-vibration mounts must be fixed to the machine before positioning the unit on the ground.

Blue Box Group S.r.l.

Via Valletta, 5 - 30010

Cantarana di Cona, (VE) Italy - T. +39 0426 921111 - F. +39 0426 302222

www.blueboxcooling.com - info@bluebox.it



Blue Box Group S.r.l. a socio unico - P.IVA 02481290282

Company directed and coordinated by Investment Latour (Sweden)