

Zeta Rev

40÷233 kW



General

Chillers and reversible units with hermetic scroll compressors and plate heat exchanger. Extended range, versatile applications.

Configurations

HE: high efficiency

SLN: super low noise

/HP: reversible heat pump

LE: with remote user-side heat exchanger

/LN: low noise

/DS: with desuperheater

/DC: with total recovery

Strengths

- ▶ Chiller with low refrigerant charge
- ▶ Intelligent management of defrost cycles: Anti-Ice Circuit
- ▶ Night Shift function for noise control (option)
- ▶ BlueThink advanced control with integrated web server. Multilogic function and Blueeye® supervision system. (options)
- ▶ Flowzer: inverter driven pumps (options)



Zeta Rev

Description of accessories	8
Refrigerant circuit accessories	8
Fan accessories	10
Hydraulic circuit accessories	11
Electrical accessories	13
Network accessories	17
Other accessories	20
Technical specifications	23
Zeta Rev	23
Zeta Rev HE	25
Zeta Rev SLN	27
Zeta Rev LE	29
Ecodesign	31
Zeta Rev	35
Zeta Rev HE	37
Zeta Rev SLN	39
Electrical specifications	41
Zeta Rev - Zeta Rev LE	41
Zeta Rev HE - Zeta Rev SLN	42
Hydraulic modules	43
Zeta Rev	43
Zeta Rev HE	44
Zeta Rev SLN	45
Hydraulic modules	46
User-side exchanger flow rate fields	47
Operating limits	48
Zeta Rev	48
Zeta Rev HE - Zeta Rev SLN	50
Zeta Rev LE	52
Noise levels	54
Zeta Rev	54
Zeta Rev HE	55
Zeta Rev SLN	56
Configurations that are not possible	57
Installation advice	58
Water characteristics	58
Glycol mixtures	58
Minimum water content in the system	59
Installation site	60
Installations that require the use of treated coils	61
Aeraulic head losses and options available for the ventilating section	62



Zeta Rev

Chillers and reversible units with hermetic scroll compressors and plate heat exchanger. Extended range, versatile applications.

STRUCTURE

The structure of the unit is made of galvanized sheet-iron coated with polyester powder in RAL 5017/7035 at 180°C, which makes it highly resistant to weather conditions.

The structure is a load-bearing frame, with removable panelling lined with sound absorbing expanded polyurethane matting.

All screws and bolts are stainless steel.

REFRIGERANT

The unit is charged with refrigerant R410A, with GWP=2088 (value at 100 years).

COMPRESSORS

The compressors are hermetic orbiting spiral scroll compressors connected in tandem. They are provided with thermal overload protection by internal Klixon® or external Kriwan® module (depending on the model) and with oil equalization line. All the compressors are fitted as standard with crankcase heater.

The compressors are enclosed in a dedicated technical compartment, which can be accessed by removing the panelling to allow maintenance operations to be carried out even with units running.

SOURCE-SIDE HEAT EXCHANGER

(excluding HP units)

For the cooling only units, the exchangers are made with microchannel aluminium coils.

The microchannel coils are made using specific aluminium alloys for the tubes and for the fins. This allows the effects of galvanic corrosion to be drastically reduced to always ensure protection of the tubes that confine the refrigerant. The entire coil is also subjected to SilFLUX coating processes (or equivalent) or has zinc added to further increase its corrosion resistance.

The use of microchannel coils compared to conventional copper/aluminium coils reduces the total weight of the unit by about 10% and gives a reduction in refrigerant charge of at least 30%.

E-coated microchannel coils are available as an option. This option is strongly recommended for applications in coastal or highly industrialized areas.

To protect the exchangers from corrosion and ensure optimal operation of the unit, we advise following the recommendations given in the user, installation and maintenance manual for cleaning the coils.

For installations within a kilometre of the coast, the use of Cu/Al coils with anti-corrosion treatment is strongly recommended.

The exchanger is protected by a metal mesh.

SOURCE-SIDE HEAT EXCHANGER

(only for HP units)

The exchangers are made with finned pack coils with copper tubes and aluminium fins.

At the base of each coil, there is an Anti-Ice Circuit: this helps to prevent ice formation in the lower part of the coil and therefore allows the unit to operate even with extremely harsh temperatures and with high humidity levels.

To protect the exchangers from corrosion and ensure optimal operation of the unit, we advise following the recommendations given in the user, installation and maintenance manual for cleaning the coils. For installations within a kilometre of the coast, use of the accessory is strongly recommended Coil treated with anti-corrosion paints.

FANS

The fans are axial fans, directly coupled to a 6-pole electric motor, with integrated thermal overload protection (Klixon®) and IP 54 protection rating.

The fan includes the shroud, designed to optimize its efficiency and reduce noise emission to a minimum, and the safety guard.

For standard efficiency models from 3.2 to 10.2 and for HE and SLN version models from 3.2 to 7.2, the unit is fitted as standard with condensing control with fan speed adjuster. For the other models, condensing control by steps or condensing control with fan speed adjuster are available as alternative options.

USER-SIDE HEAT EXCHANGER

The exchanger is a braze-welded stainless steel plate heat exchanger, insulated with a shroud of closed-cell insulating material.

For dual circuit models, the unit uses two heat exchangers already manifolded inside the unit and therefore with a single hydraulic connection.

The exchanger is also equipped with thermostat-controlled anti-freeze heater to protect it from ice formation when the unit is not running.

REFRIGERANT CIRCUIT

Each refrigerant circuit of the basic unit (cooling only) comprises:

- valve on the liquid line
- charging valves
- liquid sight glass
- replaceable solid cartridge dehydrator filter (except for sizes 3.2, 4.2 and 5.2 where the filter is a weld-on filter)
- thermostatic expansion valve with pressure equalization
- high and low pressure switches

The pipes of the circuit and the exchanger are insulated with extruded closed-cell expanded elastomer.

As an accessory, all the units can be fitted with an electronic expansion valve that allows machine stability to be reached more quickly and better superheating control than the mechanical expansion valve, to maximize the use of the evaporator in all load conditions.

ELECTRICAL CONTROL PANEL

The electrical control panel is made in a painted galvanized sheet-iron box with forced ventilation and IP54 protection rating.

The electrical control panel of the basic unit comprises:

- main disconnect switch
- automatic circuit breakers for compressors with fixed calibration
- fuses for protecting the fans and auxiliary circuits
- fan contactors
- phase-cutting fan speed adjuster
- thermal magnetic circuit breakers for pumps (if present)
- phase monitor
- potential-free general alarm contacts
- single potential free operating contacts for compressors, fans and pumps (when present)
- digital input for general ON/OFF
- summer/winter selection by digital input (only for HP units)
- external air temperature probe
- microprocessor controller with display accessible from the outside

All the electrical cables inside the panel are numbered and the terminal board dedicated to the customer's connections is coloured blue so that it can be quickly identified in the panel.

The power supply of the unit is 400V/3~+N/50Hz for the following models:

- Zeta Rev from size 3.2 up to size 10.2
- Zeta Rev HE from size 3.2 up to size 7.2
- Zeta Rev SLN from size 3.2 up to size 7.2

The power supply of the unit is 400V/3~/50Hz for the following models:

- Zeta Rev from size 12.2 up to size 24.4
- Zeta Rev HE from size 8.2 up to size 16.4
- Zeta Rev SLN from size 8.2 to 16.4 from size 8.2 up to size 16.4

CONTROL BLUETHINK

The unit is supplied as standard with parametric control. The advanced control can be requested as accessory.

Main controller functions parametric

The control allows the following functions:

- water temperature adjustment, with control of the water entering the user-side heat exchanger
- freeze protection
- compressor timings
- automatic rotation of compressor starting sequence
- recording of the alarm log
- RS485 serial port with Modbus protocol
- digital input for general ON/OFF
- digital input for Summer/Winter selection (only for HP units)

For further details on available functions and on displayed information, refer to the specific documentation of the controller.

By default, the serial connections present as standard are enabled only for reading from BMS. Enabling of writing from BMS is to be requested when ordering.

Main controller functions advanced

The control allows the following functions:

- water temperature adjustment, with control of the water entering the user-side heat exchanger
- freeze protection
- compressor timings
- automatic rotation of compressor starting sequence
- recording of the log of all machine inputs, outputs and states
- automatic rotation of compressor starting sequence
- recording of the alarm log
- RS485 serial port with Modbus protocol
- Ethernet serial port with Modbus protocol and integrated web server preloaded web page
- digital input for general ON/OFF
- digital input for Summer/Winter selection (only for HP units)

For further details on available functions and on displayed information, refer to the specific documentation of the controller.

By default, the serial connections present as standard are enabled only for reading from BMS. Enabling of writing from BMS is to be requested when ordering.

Main functions of the webserver (only for units with advanced control)

As standard, the Bluethink controller integrates a webserver with a preloaded web page that is accessed via password.

The web page allows the following functions to be carried out (some of these are available only for users with advanced level rights):

- display of the main functions of the unit such as unit serial n°, size, refrigerant
- display of the general status of the machine: water inlet and outlet temperatures, external air temperature, mode (chiller or heat pump), evaporating and condensing pressures, suction and discharge temperatures
- display of the status of compressors, pumps, expansion valves
- display in real time of the graphs of the main quantities
- display of the graphs of logged quantities
- display of alarm log
- management of users on several levels
- remote ON/OFF
- remote set point change
- remote time band change
- remote summer winter mode selection (only for HP units)

Human-Machine Interface

The control has a graphic display that allows the following information to be displayed:

- water inlet and outlet temperature
- set temperature and differential set points
- description of alarms
- hour meter of operation and number of start-ups of the unit, the compressors and the pumps (if present)
- high and low pressure values, and relevant condensing and evaporating temperatures
- external air temperature
- superheating at compressor suction.

Management of defrost cycles (only for HP units)

For defrost management, the control of the unit uses a sliding intervention threshold, depending on the pressures inside the unit and the external air temperature. By putting together all this information, the control can identify the presence of ice on the coil and activates the defrosting sequence only when necessary, so as to maximize the energy efficiency of the unit.

Sliding management of the defrost threshold ensures that, as the absolute humidity of outdoor air decreases, the frequency of the defrost cycles gradually decreases because they are carried out only when the ice formed on the coil actually penalizes performance.

The defrost cycle is fully automatic and is carried out using a patented defrost system (patent n° 1335232): during the initial stage, a defrost is carried out by cycle reversal with fans stopped. When the frost on the coil has melted sufficiently, reverse ventilation is activated, that is, with air flow in the opposite direction to that of normal operation, so as to facilitate the ejection of condensed water and detached ice. When the coil is clean, ventilation is reversed again and the unit resumes operation in heat pump mode.

In addition, the Anti-Ice Circuit helps to prevent ice formation in the lower part of the coil and so allows the unit to operate even with extremely harsh temperatures and with high humidity levels.

The combination of defrost cycle management with sliding intervention threshold, patented defrost system and Anti-Ice Circuit allows the number and duration of defrost cycles to be optimized and reduced to a minimum.

CONTROLS AND SAFETY DEVICES

All the units are fitted with the following control and safety components:

- user-side water temperature probe
- antifreeze probe on the user side heat exchanger
- high pressure switch with manual reset
- low pressure safety device with automatic reset, for a limited number of occurrences, managed by the controller
- compressor overtemperature protection
- fan overtemperature protection
- mechanical paddle flow switch (supplied loose)

TESTING

All units are factory-tested and supplied complete with oil and refrigerant, except for the LE and LE/HP versions that are charged with nitrogen.

VERSIONS

Alongside the basic version of the unit, there are various versions that differ in efficiency and noise levels.

HE: high efficiency unit

The high efficiency units use larger coils than the basic unit, in order to increase the ratio between exchange surfaces and capacity of the compressors. This allows all models to achieve high efficiency levels: in chiller configuration, SEER up to 4.02; in heat pump configuration (HE/HP), SCOP up to 3.59.

SLN: super low noise unit

The SLN version units use a soundproofed compressor compartment, oversize coils compared to the standard efficiency unit and fans with speed adjuster and reduced air flow rate. The speed reduction of the fans is such that, under nominal operating conditions, the air flow rate and noise level are lower than those of the basic version of the unit.

In any case, the use of the speed adjuster to reduce the air flow rate allows rotation of the fans at maximum speed when external air temperature conditions are particularly critical and therefore guarantees the same operating limits as the high efficiency version.

Also, for SLN/HP version units working in heat pump mode, the fans always operate at 100% speed and therefore guarantee the same performance levels as the high efficiency versions.

LE: unit with remote user-side heat exchanger

The LE version units are without user-side heat exchanger and thermostatic expansion valve (to be positioned on the remote heat exchanger).

The units are supplied with:

- standard solenoid valve on the liquid line
- without refrigerant charge and charged with nitrogen
- weld-on refrigerant connections closed with copper plugs

OPTIONS

/HP: reversible heat pump

The /HP units comprise (for each refrigerant circuit):

- 4-way reversing valve
- fluid accumulator
- second electronic expansion valve.
- Anti-Ice Circuit at the base of each coil

The Anti-Ice Circuit helps to prevent ice formation in the lower part of the coil and therefore allows the unit to operate even with extremely harsh temperatures and with high humidity levels.

For defrost management, the control of the unit uses a sliding intervention threshold, depending on the pressures inside the unit and the external air temperature. By putting together all this information, the control can identify the presence of ice on the coil and activates the defrosting sequence only when necessary, so as to maximize the energy efficiency of the unit.

Sliding management of the defrost threshold ensures that, as the absolute humidity of outdoor air decreases, the frequency of the defrost cycles gradually decreases because they are carried out only when the ice formed on the coil actually penalizes performance.

The defrost cycle is fully automatic and is carried out using a patented defrost system: during the initial stage, a defrost is carried out by cycle reversal with fans stopped. When the frost on the coil has melted sufficiently, reverse ventilation is activated, that is, with air flow in the opposite direction to that of normal operation, so as to facilitate the ejection of condensation water and detached ice. When the coil is clean, ventilation is reversed again and the unit resumes operation in heat pump mode.

The combination of defrost cycle management with sliding intervention threshold, patented defrost system and Anti-Ice Circuit allows the number and duration of defrost cycles to be optimized and reduced to a minimum.

Summer/winter switching can be done from the control keypad, digital input or BMS (requires write enabling).

/DC: unit with recovery condenser

In addition to the set-up of a chiller only unit, /DC units comprise:

- a heat recovery condenser for recovering 100% of the condensation heat on each refrigerant circuit. The exchanger is a brazed plate heat exchanger; for dual circuit units, the heat exchangers are to be manifolded outside the unit (by the customer)
- temperature probe at the inlet of the heat recovery heat exchanger; for dual circuit units, the probe is supplied with the unit and is to be positioned on the heat exchanger inlet manifold (by the customer)
- liquid receiver for each refrigerant circuit with system for emptying the refrigerant from the condensing coil
- potential free contact in the electrical control panel for activation of recovery.

When required by the system, through the closing of a contact, the control automatically manages activation of recovery. Recovery management is carried out through a control on the temperature of the return water. The control also automatically manages safety deactivation of recovery if the condensing pressure becomes too high, and changes to using the condensing coils.

This option is not available for /HP units

/DS: unit with desuperheater

In addition to the set-up of a chiller only unit, /DS units include a heat exchanger for condensation heat recovery.

The brazed plate heat recovery heat exchanger is placed in series with the condensing coil. One of these is required for each refrigerant circuit of the unit; for dual circuit units, the heat exchangers are to be manifolded outside the unit (by the customer).

Condensation heat recovery is a function of size, version and operating conditions.

An illustrative graph is shown below in which, as the ambient temperature changes, (T_{air}) and as the temperature of the water leaving the heat recovery heat exchanger changes, ($T_{w,out DS}$), the percentage of recovered heat is shown as an indication (Recovery ratio).

Condensation heat recovery is a function of size, version and operating conditions.

The percentage of recovered heat is calculated as the ratio between recovered heat flow to the desuperheater and the heat flow to the condenser under nominal conditions, therefore evaporator inlet-outlet water temperature 12-7°C.

In the following graph, a constant temperature delta of 5°C between water inlet and outlet at the heat recovery heat exchanger has been considered.

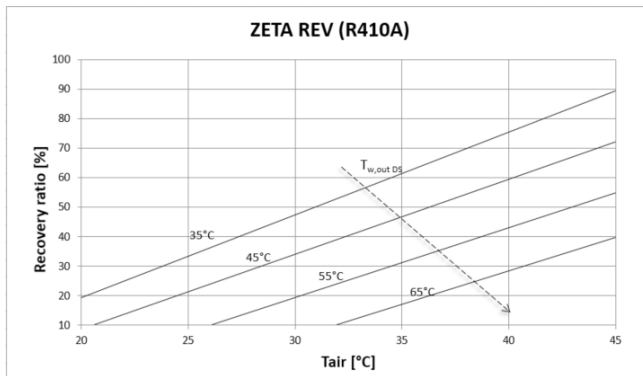

To maximize the use of the accessory and optimize machine operation, combination with the speed adjuster of the fans or with the EC fans is recommended.

This option is also available for /HP units, but in this case, in the installation, provision must be made for shutting off the heat recovery water circuit during operation in heat pump mode to avoid taking power from the user-side heat exchanger.

/LN: low noise unit

In the unit with /LN option, all the compressors are enclosed in a compartment that is fully soundproofed with sound absorbing material and soundproofing material.

HYDRAULIC MODULES

All units can be fitted with hydraulic module in various configurations:

- /1P: hydraulic module with one pump
- /2P: hydraulic module with two pumps
- /1PS: hydraulic module with one pump and buffer tank
- /2PS: hydraulic module with two pumps and buffer tank

All the above-mentioned modules have pumps with standard discharge head.

The following are also available:

- modules /1PM, /2PM, /1PMS and /2PMS that have pumps with increased available discharge head
- modules /1PG, /2PG, /1PGS and /2PGS that have pumps suitable for operating with glycol up to 50%

Hydraulic modules with one pump have:

- one pump
- an expansion vessel

Hydraulic modules with two pumps have:

- two pumps
- a check valve on the delivery side of each pump
- an expansion vessel

In the version with 2 pumps, these are always with one on standby while the other is working. Switching over between the pumps is automatic and is done by time (to balance the hours of operation of each one) or in the event of failure.

Hydraulic modules with tank also have:

- a gate valve at the inlet of the pump or the suction manifold
- a tank with drain valve and air valve

Refer to the table of configurations that are not possible to check for availability of specific set-ups.

All the hydraulic circuit components are fully insulated, except for:

- drain valves
- venting valves
- tank plugs
- safety valves
- expansion vessel
- probe pockets

DESCRIPTION OF ACCESSORIES

Some accessories may be incompatible with each other even if not expressly indicated.

Refrigerant circuit accessories

BC Capacitive backup battery for electronic expansion valve

When the compressors stop, the controller always closes the electronic expansion valve to prevent dangerous refrigerant migration. The presence of the backup battery ensures that the electronic valve is kept in closed position even when there is no power supply

This accessory uses a condenser, and not an ordinary battery, as energy storage: this allows it to be unaffected by the memory effect of normal batteries and eliminates its need for maintenance.

BK Brine Kit

This accessory is compulsory if a water temperature set point lower than or equal to +3°C is used (if the unit is provided with double set point or variable set point, the lower set point is considered).

The accessory consists of increased insulation and suitable sizing and calibration of some components.

The inlet and outlet temperatures of the user-side exchanger must be given on ordering to allow correct setting of the alarm parameters and verification of the sizing of the expansion valve.

The cooling set point can then be changed by the customer in an interval that, compared to the set point given on ordering, ranges from -1K up to the allowed limit temperature.

The unit will be optimized to work at the set point temperature given on ordering. For different set points, the cooling capacity provided and the level of efficiency of the machine could decrease and move away from these conditions.

This accessory obligatorily requires insertion of one of the condensation control options.

BT Backup battery for electronic expansion valve

When the compressors stop, the controller always closes the electronic expansion valve to prevent dangerous refrigerant migration. The presence of the backup battery ensures that the electronic valve is kept in closed position even when there is no power supply

DVS Double safety valve

With this accessory, instead of each individual safety valve per circuit, there is a "candelabrum" with two safety valves and a diverter valve for choosing the valve in operation. This allows the safety valves to be replaced without having to drain the machine and without having to stop it.

MAFR Pressure gauges

The operating pressures of each circuit of the unit can be displayed on the control by accessing the relevant screens. Also, the machine can be fitted with pressure gauges (two for each circuit) installed in a clearly visible position. These allow reading in real time of the working pressures of the refrigerant gas on the low pressure side and on the high pressure side of each refrigerant circuit.

RG Fan speed adjuster

The control manages the speed of the fans through a phase cutting speed adjuster, in order to optimize the operating conditions and efficiency of the unit.

This control also has the effect of reducing the noise level of the unit: in fact, the typical conditions under which the control will be modulating the speed of the fans are those of the night, spring and autumn.

For units equipped with EC fans, the same function is carried out using the electronically commutated motor of the fans and is supplied as standard.

RIC Liquid receiver

The adoption of this accessory always guarantees correct feeding of the expansion valve even when the unit is subjected to wide external air temperature ranges.

This accessory is standard on DC and HP units.

-
- RPP Refrigerant leak detector with automatic pump down**
With this accessory, a refrigerant leak detector is placed inside each compressor compartment. Detection of a refrigerant leak is managed by the control through a specific alarm and display of a specific icon on the display of the control. For all the circuits of the unit, the alarm also starts the machine stopping procedure with pump down, confining all the refrigerant in the coils.
The accessory includes the capacitive backup battery.
The accessory can be applied only to units in LN or SLN set-up.
- RPR Refrigerant leak detector**
With this accessory, a refrigerant leak detector is placed inside each compressor compartment. Detection of a refrigerant leak is managed by the controller through a specific alarm and display of a specific icon on the display of the controller. This alarm stops the unit.
The accessory can be applied only to units in LN or SLN set-up.
- RUB Compressor suction and delivery valves**
The valves situated on the delivery side and on the suction side of the compressors allow the compressor to be isolated from the rest of the refrigerant circuit, so making the maintenance operations quicker and less invasive
- TEMP Condensing control by steps**
With this accessory, the condensing pressure of the unit is controlled through the stepped switching off of the fans. There are two steps for units with 2 fans and three steps for units with 3 or 4 fans.
- VS Liquid line solenoid valve**
This accessory prevents refrigerant migration that could damage the compressor on starting.
- VTE Electronic expansion valve**
The use of this component is particularly advisable on units operating in very variable heat load or operating mode conditions, as in the case of joint management of air conditioning and high temperature water production. The use of an electronic thermostatic valve allows you to:
- maximize heat exchange at the evaporator
 - minimize response times to changes in load and operating conditions
 - optimize control of overheating
 - ensure maximum energy efficiency

Fan accessories

VEC EC fans

With this accessory, EC fans, with electronically commutated brushless motor, are used for the ventilating section. These guarantee very high efficiency levels for all working conditions and allow a 15% saving on the power absorbed by each fan working at full capacity.

Also, through a 0-10V analogue signal sent to each fan, the microprocessor carries out condensation/evaporation control by continuous adjustment of the air flow rate as the external air temperature changes, with a further reduction in electrical absorption and noise emission.

VEM Oversize EC fans

With this accessory, oversize EC fans, with electronically commutated brushless motor, are used for the ventilating section. These guarantee very high efficiency levels for all working conditions. Through a 0-10V analogue signal sent to each fan, the microprocessor carries out condensation/evaporation control by continuous adjustment of the air flow rate as the external air temperature changes, with a further reduction in electrical absorption and noise emission.

Oversize EC fans allow a residual available discharge head of about 100Pa to be obtained.

RECP Pressure recuperator

Normally, the air ejected by the fan has a high speed and this manifests itself as kinetic energy that is dissipated into the environment.

The pressure recuperator is a passive element situated on the ejection duct of each individual fan designed to allow better conversion of kinetic energy into static pressure, which manifests itself as a higher pressure generated by the fan.

This higher pressure can have at least two possible applications:

- For the same fan speed, the pressure recuperator allows an increase of about 50Pa in the available pressure of the ventilating section to be obtained. This can be useful for overcoming the head losses that may be present in specific installations. The increase in available pressure is to be considered in addition to the increase that can already be obtained with the application of oversize EC fans
- for the same pressure differential on the air, the pressure recuperator allows the same air flow rate to be obtained with a lower number of revolutions of the fan. This automatically produces a reduction of up to 3 dB(A) in the noise emission of the unit and a reduction in the absorption of the fan, with an immediate increase in the overall efficiency of the unit.

The reduction in total sound power varies depending on the model and version of the unit as it is related to the incidence of noise generated only by the fan section on the total noise emitted by the unit.

For SLN units, which already work with a reduced air flow rate, application of the pressure recuperator has a limited or negligible noise reduction effect.

To allow optimization of the performance of the accessory, combination with the speed adjuster or EC fans is necessary. In this last case, the higher efficiency of the EC fans (especially when operating at low speed) is added to the performance improvement generated by the pressure recuperator.

The accessory is supplied separately from the unit on one or more pallets and it must compulsorily be installed (by the customer) before the first start-up of the machine.

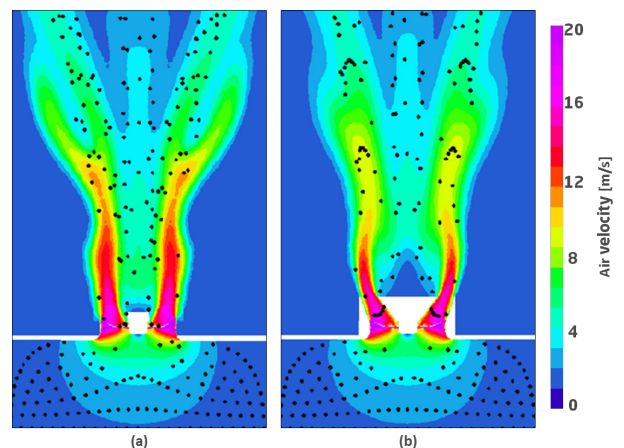
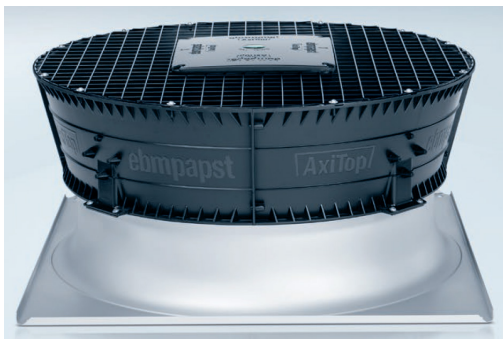

(a) fan only;

(b) fan with pressure recuperator

Hydraulic circuit accessories

CORM Connection for manual filling

This accessory allows the system filling procedure to be carried out directly from the unit: on the fan holder cover, there is a 1" filling valve and a 1/2" air valve. Near the filling valve, there is also a pressure gauge for displaying the pressure in the hydraulic circuit. This accessory can be combined only with units provided with tank.

FLUS Flow switch (instead of the water differential pressure switch)

As an alternative to the differential pressure switch (standard flow sensor), it is possible to request the paddle flow switch as accessory. This detects when there is no water flow to the user-side exchanger and sends a signal to the control of the unit that will stop the compressors to prevent damage to the exchangers.

Application of this accessory is compulsory for units that use non-glycol water and work with a yearly cycle where external air temperatures are zero or below.

The flow switch is supplied loose (installation by the customer) and replaces the water differential pressure switch (standard).

FVD FLOWZER VD - Transducer for automatic adjustment

Flowzer VD requires a pressure transducer to be installed in the machine. Through this transducer, the inverter can gauge the actual pressure at the ends of the system and automatically adapt the pump speed to obtain a set available discharge head value. Flowzer VD must be combined with Flowzer VP. This accessory therefore allows a constant pressure system to be achieved.

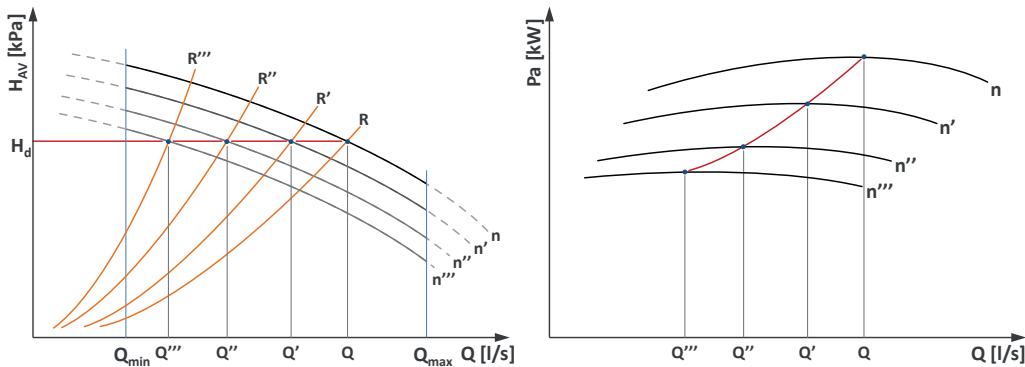

With the Flowzer VD, the customer can set, directly on the inverter, the available discharge head value H_d that the unit must maintain. As can be seen in the graph, as the system user points close, the resistance curve of the system shifts to the left and therefore the inverter will be able to reduce the pump speed in order to keep the available discharge head of the unit constant. By doing so, an immediate reduction in the power absorbed by the pump will be obtained. The customer will have to check that, in minimum flow rate conditions (that is, with the maximum number of user points closed), this is always higher than or equal to the minimum flow rate allowed by the unit.

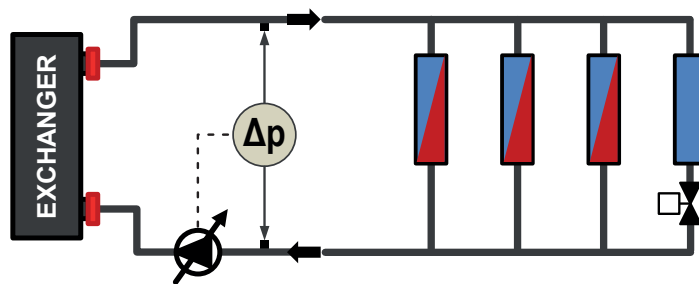

This accessory is useful when the total head losses of the circuit are slightly variable or when they change depending on the seasons (for example, some user points are active only during summer operation and not during winter operation).

The use of this accessory also allows the pump speed to be adapted to possible fouling of the filter on the hydraulic circuit.

FVP **FLOWZER VP - Inverter for manual pump adjustment**

The accessory consists of inserting an inverter in the machine to manually adjust the speed of the pump (or pumps) in order to calibrate the pump flow rate on the head losses of the system.

This accessory is to be combined with one of the integrated hydraulic modules that can be selected for the unit. Units equipped with integrated hydraulic module allow a certain level of available discharge head (point A) to be obtained under nominal flow rate conditions Q_d .

But the actual head loss level of the system (e.g. characteristic curve R') normally causes the pump to find a different equilibrium point (point B), with a flow rate Q_r higher than Q_d .

In this condition, besides having a different flow rate from the nominal flow rate (and therefore also a different thermal gradient), there is also higher pump power absorption.

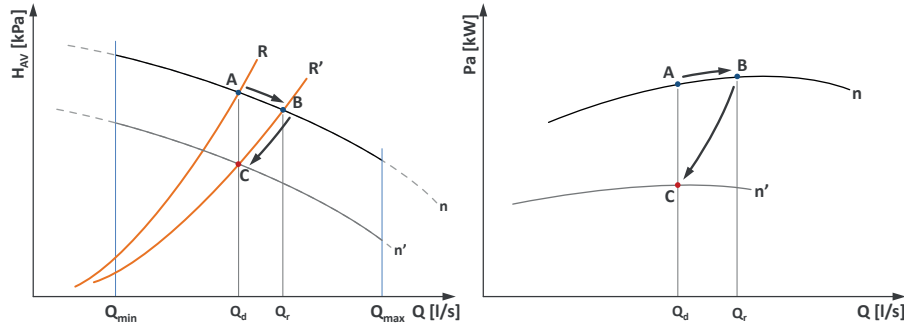

The use of the Flowzer allows the pump speed to be set manually (e.g. at speed n' instead of n) to obtain the design water flow rate and thermal gradient (point C). Once the adjustment procedure has been carried out, the pump will always work at a fixed flow rate.

Use of the Flowzer VP allows the power absorption of the pump to be considerably reduced with consequent energy saving. By way of example:

- a 10% reduction in flow rate gives a reduction in absorbed power of about 27%

IVPO **Soundproofed pump compartment**

With this accessory, the motor and the impeller of the pumps are enclosed in a compartment that is fully soundproofed with sound absorbing material and soundproofing material.

PFP **User-side pump with Pulse function**

As standard, the unit is set to keep the system-side circulation pump on all the time, even when the set point temperature is reached.

But when the unit is provided with this accessory, on reaching the set point, the controller will switch off the pump and start it again at regular intervals for a sufficient time to measure the water temperature. If the controller verifies that the water temperature is still in set point condition, it will switch off the pump again. Otherwise the controller will start the compressors again to meet the requirements of the system.

This accessory therefore allows electrical absorption due to pumping to be drastically reduced, especially in spring and autumn when the load is extremely low.

RA **Antifreeze heater**

These are electric heaters inserted on the user-side heat exchanger, on the pumps and in the tank (depending on the configuration of the machine) to prevent damage to the hydraulic components due to ice formation during periods when the machine is stopped.

Based on normal operating conditions and the percentage of glycol in the system, an appropriate "antifreeze alarm" temperature is set in the control. When a temperature that is 1K higher than the antifreeze alarm threshold is detected at the outlet from the exchanger, the pump (if present) and the antifreeze heaters are switched on. If the temperature of the outgoing water reaches the antifreeze alarm threshold, the compressors are stopped, keeping the heaters and the pumps active, and the general alarm contact of the machine is activated.

VSIW **Water-side safety valve**

With this accessory, a safety valve is inserted in the hydraulic circuit of the unit: when the calibration pressure is reached, the valve opens and, by discharging (to be routed by the customer), prevents the system pressure from reaching limits that are dangerous for the components present in the system. The valves have positive action, that is, performance is guaranteed even if the diaphragm deteriorates or breaks.

Electrical accessories

A41 Power supply 415/3/50

Power supply 415/3/50. Available for the following units: for Zeta Rev and Zeta Rev LE from size 12.2 up to size 24.4, for HE and SLN configurations from size 8.2 up to size 16.4

A41N 415/3+N/50 power supply

415/3+N/50 power supply. Available for the following units: for Zeta Rev and Zeta Rev LE from size 3.2 up to size 10.2, for HE and SLN configurations from size 3.2 up to size 7.2.

A43 Power supply 400/3/50

Power supply present as standard in the following units: for Zeta Rev and Zeta Rev LE from size 12.2 to size 24.4, for HE and SLN configurations from size 8.2 to size 16.4

A43N Power supply 400/3+N/50

Power supply present as standard in the following units: for Zeta Rev and Zeta Rev LE from size 3.2 to size 10.2, for HE and SLN configurations from size 3.2 to size 7.2.

ARU Stopping of the unit due to temperatures below the operating limit

With this accessory, it is possible to set the unit so that the controller switches off the compressors when the unit is operating in heat pump mode and the external air temperature falls below a minimum set limit: this will prevent the unit from going into low pressure alarm, so avoiding having to manually restart the machine. When the external air temperature returns above the set threshold temperature, the unit will automatically resume operation without it being necessary to do anything.

For units equipped with integrated pump, the pump will always be kept running so as to prevent ice formation and ensure correct reading of the temperature and antifreeze safety probes at all times.

The stopping temperature must be set based on the set point temperature and in accordance with what is allowed by the operating limits of the machine.

The same function can be used to set an external air temperature below which to use an alternative heat source because it is more efficient or economically more advantageous.

With the default programming, the limit that considers a production of outgoing water at 45°C is set, therefore:

- -7°C for standard units
- -10°C for /HE and /SLN units.

CA Advanced control

With this accessory, the advanced control is used also for sizes/versions provided with the parametric control as standard.

COTW Outgoing water temperature control

With this accessory, outgoing instead of incoming water temperature control is used.

CP Single potential free operating contacts

For units fitted with this accessory, clean contacts from which the customer can acquire signals that are shown in the terminal board of the electrical control panel.

CSP Set point compensation depending on external air temperature

For units fitted with this accessory, the set point of the unit is set so that it can vary between two values, a maximum and a minimum, depending on the external air temperature. The compensation ramp and the maximum and minimum values of the set point can be changed by the user.

Unless otherwise specified in the order, the controller will be set to implement a positive compensation logic according to the temperatures shown in the following diagrams:

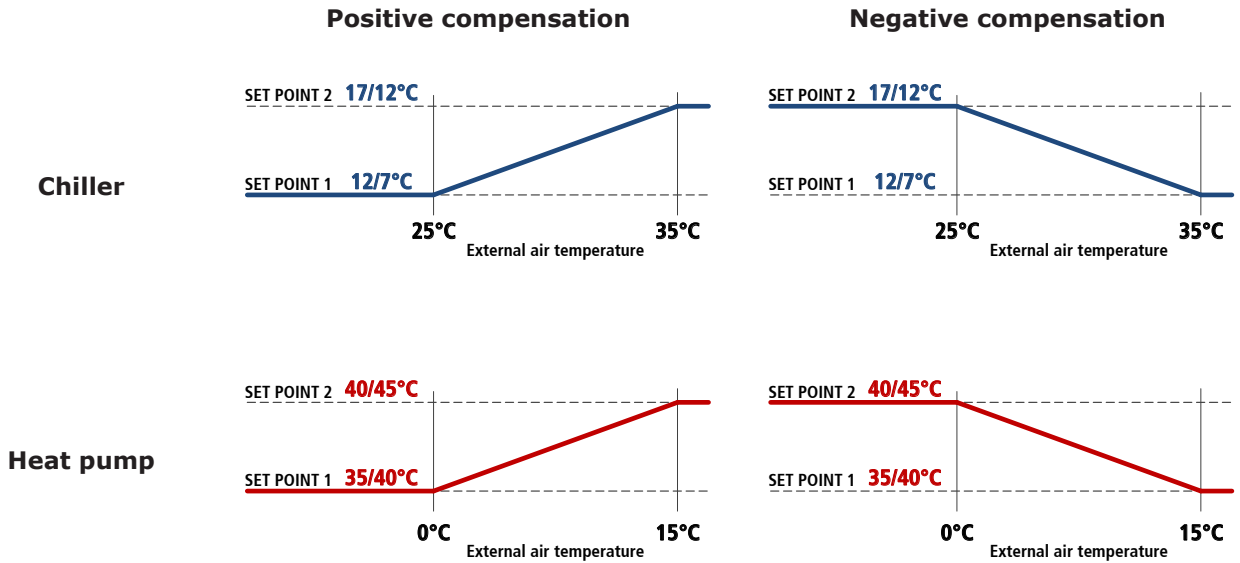

IA Automatic circuit breakers (instead of fuses)

This accessory requires the installation of automatic circuit breakers, instead of fuses, for the protection of auxiliary loads. Also, the same accessory uses automatic circuit breakers with adjustable thermal overload protection to protect the compressors.

LIID Limitation of the current absorbed by digital input

When this accessory is requested, a digital input is prepared in the terminal board to activate the forced capacity reduction of the unit to a set fixed level.

This accessory is useful when there is a need to necessarily limit the power absorbed by the unit as regards particular conditions.

We point out that, in some conditions (for example, during defrosting, oil return cycles or hourly compressor rotation procedures), the controller could force the unit to operate at full capacity for limited periods of time.

NSS Night Shift System

This accessory is applied to high efficiency /LN version units with speed adjuster or to SLN units.

In the day time band, which is normally the one with the highest heat load, priority is given to efficiency and therefore the machine works with a fan control curve that maximises the EER. In this time band, therefore, the unit is a high efficiency low noise machine (equivalent to HE/LN). In the night time band (or in any case from time band decided by the customer), the priority changes to limiting the noisiness of the machine and therefore the controller carries out an adjustment of the control ramp of the condensing fans, thereby reducing the air flow rate and consequently the noise emission level. So, in this time band, the unit is a super low noise machine (equivalent to SLN). In any case, if there is a need for additional cooling capacity, the controller will manage the demand, if necessary, by accelerating the fans and keeping condensation within the correct operating limits. The time slots can be set from the control depending on installation requirements.

When the unit is working in heat pump mode, in order to maximise the COP and to obtain the widest possible operating limits, the control of the unit forces the fans to the maximum speed also during the night time bands.

RE1P Relay for management of 1 external pump

This accessory can be requested for units without pumps and allows a pump outside the machine to be controlled.

RE2P Relay for management of 2 external pumps

This accessory can be requested for units without pumps and allows two pumps outside the machine to be controlled with a running/stand-by logic by implementing a rotation on the hours of operation.

RIF Power factor correction to $\cos\phi \geq 0.95$

With this accessory, an electrical control panel, containing power factor correction capacitors to make the $\cos\phi$ of the unit greater than or equal to 0.95, is supplied with the unit. The capacitors should be connected (by the customer) to the electrical control panel of the unit in the specially prepared terminal board.

Besides reducing the absorbed reactive power, the use of this accessory also allows the maximum absorbed current to be lowered.

RMMT Maximum and minimum voltage relay

This accessory constantly monitors the voltage value and the unit's power supply phase sequence. If the supply voltage does not fall within the set parameters or there is a phase reversal, an alarm is generated that stops the machine to prevent damage to its main parts

SETD Double set point from digital input

The accessory allows you to preset two different operating set points and manage the change from one to the other through a digital signal.

The set point temperatures must be specified when ordering. For optimization of the unit, reference will be made to the lower set point in chiller mode and the higher set point in heat pump mode.

Unless otherwise specified in the order, the controller will be set at the factory with the following temperatures:

- in chiller mode, set point 1 to 7°C and set point 2 to 12°C
- in heat pump mode (only for HP units) set point 1 to 45°C and set point 2 to 40°C

If the difference between set point 1 and set point 2 is greater than 5K, it is compulsory to ask for the accessory "Electronic expansion valve".

SETV Variable set point with remote signal

The accessory allows the set point to be varied continuously between two preset values, a maximum and a minimum, depending on an external signal that can be of the 0-1V, 0-10V or 4-20mA type.

The set point temperatures and the type of signal to use for the adjustment must be specified when ordering. For optimization of the unit, reference will be made to the lower set point in chiller mode and the higher set point in heat pump mode.

Unless otherwise specified in the order, the controller will be set at the factory with 0-10V analogue input and with the following temperatures:

- in chiller mode, 0V will correspond to a set point of 7°C and 10V will correspond to a set point of 12°C
- in heat pump mode (only for HP units), 0V will correspond to a set point of 45°C and 10V will correspond to a set point of 40°C

If the difference between the minimum set point and the maximum set point is greater than 5K, it is compulsory to ask for the accessory "Electronic expansion valve".

SOFT Electronic soft-starter

The scroll compressors have DOL (Direct On Line) starting and therefore the maximum inrush current I_{MIC} will be 4/5 times its nominal current I_{nom} .

If the unit is equipped with the electronic soft-starter accessory, the starting of each compressor is done with an acceleration ramp that allows the effective value (rms value) of the inrush current of the individual compressor to be lowered.

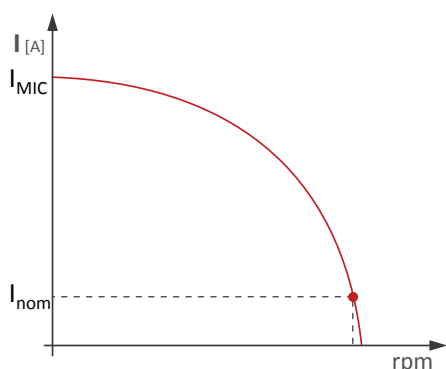

Current trend without accessory Electronic soft-starter

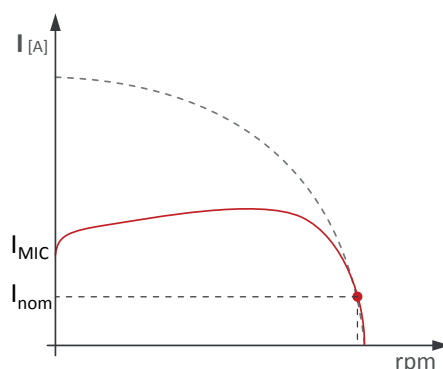

Current trend with accessory Electronic soft-starter

If the unit is equipped with accessory "Power factor correction to $\cos\phi \geq 0.95$ ", this last will be electro-mechanically connected only at the end of the acceleration ramp of the soft-starter.

SQE Heater for electrical control panel

Electric heaters are positioned inside the electrical control panel and these prevent the formation of ice or condensation inside it.

TERM Remote-controlled user terminal panel

This accessory allows the terminal normally situated on the machine to be replicated on a support situated at a distance. It is particularly suitable when the unit is placed in an area that is not easily accessible.

The accessory is supplied loose and is to be installed by the customer at a maximum distance of 120m from the unit. We advise using a cable of the following type: "TECO O.R. FE 2x2xAWG24 SN/ST/PUR".

For this accessory, there is a dedicated serial port.

Network accessories

BEET Blueeye® via Ethernet

This accessory does not include any type of **Blueeye® Service**. This service must be purchased separately based on the number of units/devices to be connected and the number of variables to be monitored.

Blueeye® is a supervision platform that enables remote monitoring of one or more units in the same system interconnected through a network with Modbus protocol.

The critical variables to be monitored over time are identified for each connected device. These variables are sampled and saved to the cloud so that they are accessible at all times through a web portal or a mobile APP (available for Android and iOS).

The following options can be selected for connection to the internet:

- a LAN (Ethernet) connection - available in the system;
- a connection to a mobile network - at least 3G. The data SIM card is not included.

Subscribing to any of the Blueeye® Services enables:

- viewing the history of the monitored variables, in the form of both numerical values and graphs;
- downloading the history of variables in CSV format;
- the creation of automatic reports;
- setting notifications (via APP or mail) with settable thresholds for each variable;
- switching the unit ON/OFF remotely;
- changing the set point remotely;
- selection of SUMMER/WINTER mode remotely (for reversible units only).

Two different types of contracts can be signed.

Blueeye® Service Basic:

- to monitor a max. of 20 variables in total over max. 5 units/peripherals;
- to set a min. sampling frequency of 60 seconds.

Blueeye® Service Advanced:

- to monitor a max. of 200 variables in total over max. 10 units/peripherals;
- to set a min. sampling frequency of 5 seconds.

Both contracts can be supplemented with the following option: **VPN**. Unlike a standard connection, this option is used to create a secure connection (tunnelling) between the user and the remote unit through the Blueeye® portal. This type of connection gives full access to the remote controller and enables upgrading of the software (only for units with programmable controller).

For further details, refer to the specific Blueeye® documentation.

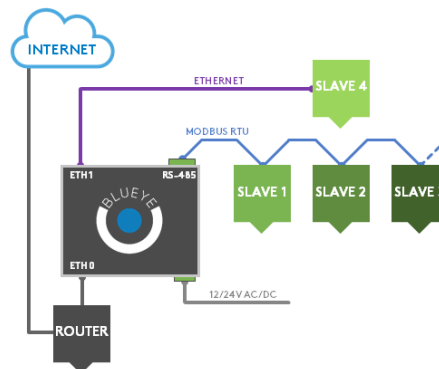

BERS Blueye® via RS485

This accessory includes installation on the machine of the **Blueye® Device**, namely the component used to connect to the cloud service for storage of unit operating data.

The Blueye® Device is already installed and wired in the unit. Up to 10 units/peripherals can be connected to one Blueye® Device (depending on the signed Blueye® Service contract) through a RS485 network with Modbus RTU protocol or an Ethernet network with Modbus protocol. If an Ethernet network is used, the unit must also be equipped with a network switch (this accessory is sold separately) having a sufficient number of ports.

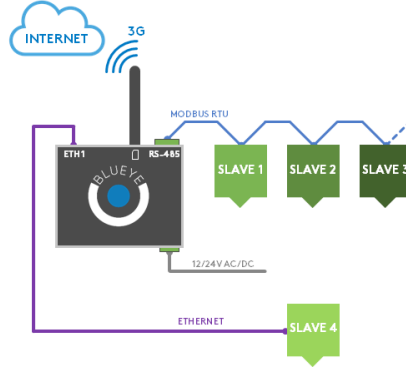

FMx Multilogic Function

The Multilogic function allows management of up to 32 units equipped with advanced Bluetink controller and connected in hydraulic parallel with each other.

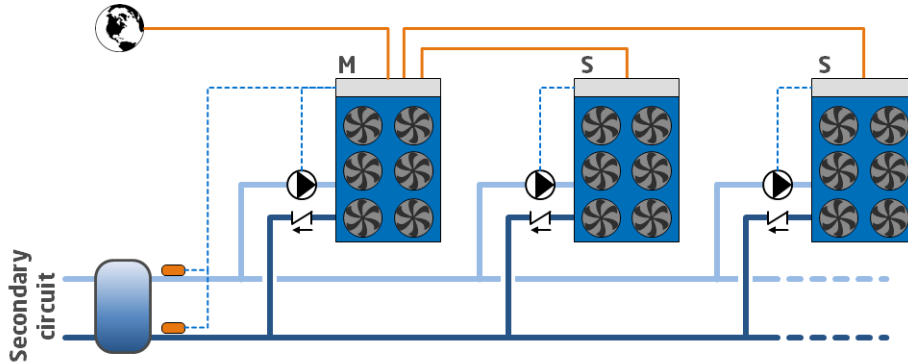

On the basis of the information recorded by the temperature probes installed on the delivery and return manifolds of the system, with the master unit, a capacity request is generated that is distributed among the units connected in the Multilogic network according to settable priority and optimization logics.

If communication between the units fails or if the master is off-line, the slave units can continue to work according to the set thermoregulation parameters.

The connected units can be different from each other, in terms of capacity and set-up, provided the following rules are complied with:

- if there are both chiller units and heat pumps in the Multilogic network, the Master unit must obligatorily be one of the HP units
- if there are both free cooling and non free-cooling units in the Multilogic network, the Master unit must obligatorily be one of the free-cooling units.

The Multilogic function that can be requested with the unit can be:

- **FM0:** Multilogic function for Slave unit
- **FM2:** Multilogic function for Master unit for managing up to 2 Slaves
- **FM6:** Multilogic function for Master unit for managing up to 6 Slaves

If you need to connect more than 6 slaves (up to 31), you can ask for a quotation from our sales department.

For the slave units, the accessory requires:

- programming of the unit as slave of a system of machines in Multilogic network

For the master units, the accessory requires:

- programming of the unit as master of a system of machines in Multilogic network
- entering of the parameters necessary for connection with the individual slave units
- installation in the electrical control panel of a network switch to allow the units to be connected in a LAN network.
- the supply of 2 temperature probes to be positioned on the delivery and return manifold of the system (supplied separately with it, installation and wiring by the customer)

The connection between the master unit and the slave units made with a CAT cable. 5E/UTP (prepared by the customer) with RJ45 connectors. Maximum cable length 100m.

For further details, please refer to the controller manual.

GLO Modbus Lonworks Gateway

With this accessory, a RS485/Lon gateway is installed inside the electrical control panel.

By default, the programming gives read-only access to the control of the unit. Enabling of read/write access should be requested when ordering.

PBA BACnet protocol over IP (Ethernet)

The controller is set for use, in read and write mode, of the BACnet port on IP protocol.

By default, the programming gives read-only access to the control of the unit. Enabling of read/write access should be requested when ordering.

SERI RS485 serial connection with Modbus protocol

RS485 serial connection with Modbus protocol

SMAR Smartlink

This accessory makes it possible to connect the controller of the unit with the controller of a Swegon GOLD™ air handling unit via a simple serial cable, so allowing their operating logics to be merged into a single consciousness that pursues the maximum energy efficiency of the system. The RS485 serial interface is already included and dedicated to connection with Swegon units.

The option is incompatible with:

- double set point
- variable set point with remote signal
- summer/winter selection by digital input
- set point compensation depending on external air temperature
- multilogic
- all communication protocols.

SW4P Network switch with 4 ports

The accessory includes installation in DIN rail of a professional 4-port network switch. Requires Blueye via Ethernet.

SW8P Network switch with 8 ports

The accessory includes installation in DIN rail of a professional 8-port network switch. Requires Blueye via Ethernet.

Other accessories

AG Rubber anti-vibration mounts

These allow you to reduce the vibrations transmitted from the unit to the surface it is standing on. Accessory supplied loose.

ALPR Pre-painted aluminium coil

This accessory uses finned pack coils with copper tubes and aluminium fins pre-painted with an anti-corrosion treatment.

ANTC Coil treated with anti-corrosion paints

The treatment is applied exclusively to finned pack coils with copper tubes and aluminium fins and consists of aluminium passivation and coating with a polyurethane base; a double layer of paint, of which the first passivates the aluminium and acts as primer and the second is a polyurethane based surface coating. The product has high resistance to corrosion and all environmental conditions.

The choice of whether or not to treat the exchanger should be made in relation to the environment in which the unit is to be installed and through observation of other structures and machinery with exposed metal surfaces present in the destination environment.

The cross observation criterion is the most valid method of selection currently available without having to carry out preliminary tests or measurements with instruments. The identified reference environments are:

- marine coastal
- industrial
- urban with a high housing density
- rural

Please note that in cases where different conditions co-exist, even for short periods, the choice must be suitable for preserving the exchanger in the harsher environmental conditions and not in conditions between the worst and best situation.

Particular attention must be given to cases where an environment that is not particularly aggressive becomes aggressive as a consequence of a local and/or temporal concomitant cause such as, for example, due to the presence of a heating flue outlet or an industrial kitchen or a solvent extraction fan in a small craft business.

Protective treatment of the exchanger is strongly recommended if at least one of the points below is verified:

- there are obvious signs of corrosion of the exposed metal surfaces in the installation area
- the distance from the coast is less than 20 km
- the prevailing winds come from the sea towards the unit
- the environment is industrial with a significant concentration of pollutants
- the environment is urban with a high population density
- the environment is rural with the presence of organic discharges and effluents.

For chiller units, this accessory also includes the "Cu/Al coil" accessory.

FW Water filter

To protect the elements of the hydraulic circuit (in particular, the exchangers), there are Y filters that can stop and settle the particles that are normally present in the water flow and would otherwise settle in the more delicate parts of the hydraulic circuit and damage its heat exchange capacity.

Installation of the water filter is mandatory even when it is not supplied as an accessory.

Accessory supplied loose.

GABB Packaging in wooden crate

The unit is protected by a made-to-measure wooden crate. The accessory is mandatory if shipping by container is required.

MCHE E-coated microchannel coil

The e-coated microchannel coils are treated by immersion of the whole exchanger in an emulsion of organic resins, solvents, ionic stabilisers and deionised water. This is all subjected to a suitable electric field that causes the formation of a solid, uniform deposit on the exchanger. The function of this deposit will be to protect the aluminium from corrosion without penalising its thermophysical properties.

The choice of whether or not to treat the exchanger should be made in relation to the environment in which the unit is to be installed and through observation of other structures and machinery with exposed metal surfaces present in the destination environment.

The cross observation criterion is the most valid method of selection currently available without having to carry out preliminary tests or measurements with instruments. The identified reference environments are:

- marine coastal
- industrial
- urban with a high housing density
- rural

Please note that in cases where different conditions co-exist, even for short periods, the choice must be suitable for preserving the exchanger in the harsher environmental conditions and not in conditions between the worst and best situation.

Particular attention must be given to cases where an environment that is not particularly aggressive becomes aggressive as a consequence of a local and/or temporal concomitant cause such as, for example, due to the presence of a heating flue outlet or an industrial kitchen or a solvent extraction fan in a small craft business.

Protective treatment of the exchanger is strongly recommended if at least one of the points below is verified:

- there are obvious signs of corrosion of the exposed metal surfaces in the installation area
- the prevailing winds come from the sea towards the unit
- the environment is industrial with a significant concentration of pollutants
- the environment is urban with a high population density
- the environment is rural with the presence of organic discharges and effluents.

PREA Unit suitable to be disassembled on site

The unit is delivered so that it can be disassembled easily on site if this makes the installation operations easier.

A unit requested with this option is supplied:

- screwed instead of riveted
- with plugged and not welded pipes
- without refrigerant charge
- untested
- covered by the warranty only if reassembled and screwed together by personnel authorized by the factory

RAAL Cu/Al coils

This accessory uses finned pack coils with copper tubes and aluminium fins instead of microchannel coils.

RAV Anti-freeze heater for condensate drip tray

A heating cable, glued to the bottom, can be combined with the condensate drip tray to prevent ice formation at the base of the coil or near the drains.

The heater is controlled by a thermostat and is activated depending on the external air temperature.

RETE Coil protection mesh with metal filter

Coil protection mesh with hail-proof metal filter

SLIT Special pallet/skid for container shipment

The unit is placed on a skid that makes the container loading and unloading operations easier.

The accessory is mandatory if shipping by container is required

VASC Condensate drip tray

This accessory can be combined with HP units in order to collect the condensate that forms after each coil defrost cycle. The tray is made of stainless steel and is placed under the source-side heat exchanger, at a suitable distance.

On the opposite sides of the tray, there are some 1" close nipples to allow the customer to connect a pipe to it for draining out the water so as not to cause harm or damage to people or objects.

TECHNICAL SPECIFICATIONS

ZETA REV

			3.2	4.2	5.2	6.2	7.2	8.2	9.2	10.2	12.2
ZETA REV											
Cooling											
Refrigeration capacity	(1)	kW	40,4	45,3	52,9	59,6	66,7	80,9	92,8	101,9	116,2
Total absorbed power	(1)	kW	13,9	16,7	20,2	20,7	24,4	26,5	31,1	36,1	41,6
EER	(1)		2,91	2,71	2,62	2,88	2,73	3,06	2,98	2,82	2,79
Eurovent efficiency class	(1)		B	C	D	C	C	B	B	C	C
ESEER			4,15	4,11	4,07	4,19	4,09	4,20	4,25	4,12	4,03
ZETA REV /HP											
Cooling											
Refrigeration capacity	(1)	kW	39,8	44,7	52,3	58,6	65,8	80,1	90,3	98,0	113,9
Total absorbed power	(1)	kW	14,2	17,0	19,9	21,2	24,8	27,2	32,2	38,0	42,7
EER	(1)		2,81	2,63	2,63	2,77	2,66	2,95	2,80	2,58	2,67
Eurovent efficiency class	(1)		C	D	D	C	D	B	C	D	D
ESEER			4,08	4,07	4,08	4,11	4,05	4,13	4,16	4,05	3,96
Heating											
Heating capacity	(2)	kW	42,1	47,1	55,4	63,2	70,1	83,7	94,7	104,2	121,7
Total absorbed power	(2)	kW	13,6	15,7	18,1	20,0	22,0	26,3	29,8	33,4	39,2
COP	(2)		3,08	3,00	3,06	3,16	3,18	3,19	3,18	3,12	3,10
Eurovent efficiency class	(2)		B	C	B	B	B	B	B	B	B
Compressors											
Compressors/Circuits		n°/n°	2/1	2/1	2/1	2/1	2/1	2/1	2/1	2/1	2/1
Minimum capacity reduction step	(7)	%	50%	50%	50%	50%	50%	50%	43%	50%	44%
Refrigerant charge CH (MCHX)	(3)	kg	4,0	4,2	4,4	5,5	5,7	8,9	9,2	9,2	9,6
Refrigerant charge HP	(3)	kg	11,4	11,7	12,5	17,5	17,6	23,5	26,3	26,3	26,5
Fans											
Quantity		n°	2	2	2	2	2	3	3	3	2
Total air flow rate CH (MCHX)		m³/h	18.000	18.000	17.000	19.000	19.000	28.000	28.000	28.000	39.000
Total air flow rate HP		m³/h	16.000	16.000	15.000	18.000	18.000	26.000	26.000	26.000	36.000
User-side heat exchanger											
Quantity		n°	1	1	1	1	1	1	1	1	1
Water flow rate CH	(1)	m³/h	7,0	7,8	9,2	10,3	11,5	14,0	16,0	17,6	20,1
Pressure drop CH	(1)	kPa	37,6	32,6	32,6	42,3	21,8	32,9	28,3	33,7	34,1
Water flow rate HP	(1)	m³/h	6,9	7,7	9,0	10,1	11,4	13,8	15,6	16,9	19,7
Pressure drop HP	(1)	kPa	35,5	30,9	32,4	39,7	20,6	30,7	26,0	30,3	31,8
Noise levels											
Sound power level cooling	(4)	dB(A)	78	79	79	80	81	82	83	84	86
Sound power level heating	(5)	dB(A)	78	79	79	80	81	82	83	84	86
Sound pressure level cooling	(6)	dB(A)	46	48	48	48	49	50	51	52	54
Sound power level of vers. LN cooling	(4)	dB(A)	76	77	77	78	79	80	81	82	84
Sound power level of vers. LN heating	(5)	dB(A)	76	77	77	78	79	80	81	82	84
Sound pressure level of vers. LN cooling	(6)	dB(A)	44	46	46	46	47	48	49	50	52
Dimensions and weights**											
Length		mm	1.750	1.750	1.750	2.200	2.200	3.200	3.200	3.200	3.200
Depth		mm	1.000	1.000	1.000	1.000	1.000	1.100	1.100	1.100	1.100
Height		mm	1.400	1.400	1.400	1.740	1.740	1.740	1.740	1.740	1.880
Operating weight		kg	416	428	430	560	586	802	814	826	968

CH: chiller unit; HP: heat pump unit; MCHX: unit with microchannel coils

(1) External air temperature 35°C, user-side heat exchanger water inlet/outlet temperature 12/7°C. Values in accordance with EN 14511.

(2) Outside air temperature 7°C DB, 6°C WB; condenser inlet/outlet water temperature 40/45°C. Values in accordance with EN 14511.

(3) Theoretical values referred to the basic unit. The amount of gas actually charged in the unit may differ.

(4) Unit operating at nominal operating capacity, without any accessories, with external air temperature of 35°C and user-side heat exchanger water inlet-outlet temperature of 12-7°C. Binding values. Values obtained from measures taken according to standard ISO 3744 and to the Eurovent certification programme where applicable.

(5) Unit operating at nominal operating capacity, without any accessories, with external air temperature of 7°C (6°C wb) and user-side heat exchanger water inlet-outlet temperature of 40-45°C. Values obtained from measures taken according to standard ISO 3744.

(6) Values obtained from the sound power level (conditions: note 4), related to a distance of 10m from the unit in free field with directivity factor Q=2. Non-binding values.

(7) Approximate value. The minimum capacity reached by the unit depends on the operating conditions. The value shown may not be suitable for calculating the minimum volume of water: to do this, consult the "Minimum water content in the system" section.

** Basic CH unit without included accessories

ZETA REV

			13.2	14.4	15.2	16.2	16.4	18.4	20.4	24.4
ZETA REV										
Cooling										
Refrigeration capacity	(1)	kW	125,1	136,8	146,2	159,1	153,4	189,3	207,7	233,3
Total absorbed power	(1)	kW	47,9	53,0	61,8	47,4	58,1	62,2	72,0	82,9
EER	(1)		2,61	2,89	2,76	2,58	2,64	3,04	2,88	2,81
Eurovent efficiency class	(1)		D	C	C	D	D	B	C	C
ESEER			3,86	4,21	4,03	3,92	4,11	4,28	4,22	4,18
ZETA REV /HP										
Cooling										
Refrigeration capacity	(1)	kW	122,7	132,3	141,5	153,1	148,1	182,5	198,8	224,1
Total absorbed power	(1)	kW	49,0	55,1	64,5	49,3	60,3	65,1	76,0	86,7
EER	(1)		2,51	2,69	2,57	2,37	2,45	2,81	2,62	2,58
Eurovent efficiency class	(1)		D	D	D	E	E	C	D	D
ESEER			3,79	4,15	3,92	3,80	4,05	3,95	3,83	3,84
Heating										
Heating capacity	(2)	kW	132,8	143,3	153,2	168,4	162,3	194,3	211,9	237,8
Total absorbed power	(2)	kW	43,4	49,0	54,7	45,0	52,1	61,0	68,2	78,1
COP	(2)		3,06	3,18	3,13	3,08	3,12	3,18	3,11	3,04
Eurovent efficiency class	(2)		B	B	B	B	B	B	B	B
Compressors										
Compressors/Circuits		n°/n°	2/1	2/1	2/1	4/2	4/2	4/2	4/2	4/2
Minimum capacity reduction step	(7)	%	50%	45%	50%	25%	25%	21%	25%	22%
Refrigerant charge CH (MCHX)	(3)	kg	9,6	15,7	15,7	15,9	15,9	24,6	24,6	25,4
Refrigerant charge HP	(3)	kg	26,5	39,5	39,5	42,5	44,3	55,5	55,5	55,9
Fans										
Quantity		n°	2	2	2	2	2	3	3	4
Total air flow rate CH (MCHX)		m³/h	39.000	42.000	42.000	42.000	42.000	63.000	63.000	76.000
Total air flow rate HP		m³/h	36.000	40.000	40.000	40.000	40.000	58.000	58.000	70.000
User-side heat exchanger										
Quantity		n°	1	1	1	2	2	2	2	2
Water flow rate CH	(1)	m³/h	21,6	25,3	27,5	23,6	26,5	32,7	35,9	40,3
Pressure drop CH	(1)	kPa	39,2	34,9	40,9	22,8	28,2	29,3	34,9	34,3
Water flow rate HP	(1)	m³/h	21,2	24,4	26,4	22,8	25,6	31,5	34,3	38,7
Pressure drop HP	(1)	kPa	36,5	31,7	36,7	20,7	25,5	26,5	31,1	30,9
Noise levels										
Sound power level cooling	(4)	dB(A)	87	87	87	84	85	87	89	90
Sound power level heating	(5)	dB(A)	87	87	87	84	85	87	89	90
Sound pressure level cooling	(6)	dB(A)	55	55	55	52	53	55	57	58
Sound power level of vers. LN cooling	(4)	dB(A)	85	85	85	82	83	85	87	88
Sound power level of vers. LN heating	(5)	dB(A)	85	85	85	82	83	85	87	88
Sound pressure level of vers. LN cooling	(6)	dB(A)	53	53	53	50	51	53	55	56
Dimensions and weights**										
Length		mm	3.200	3.200	3.200	3.200	3.200	4.200	4.200	4.200
Depth		mm	1.100	1.100	1.100	1.100	1.100	1.100	1.100	1.100
Height		mm	1.880	2.380	2.380	2.380	2.380	2.380	2.380	2.380
Operating weight		kg	1.012	1.168	1.168	1.208	1.312	1.596	1.626	1.750

CH: chiller unit; HP: heat pump unit; MCHX: unit with microchannel coils

(1) External air temperature 35°C, user-side heat exchanger water inlet/outlet temperature 12/7°C. Values in accordance with EN 14511.

(2) Outside air temperature 7°C DB, 6°C WB; condenser inlet/outlet water temperature 40/45°C. Values in accordance with EN 14511.

(3) Theoretical values referred to the basic unit. The amount of gas actually charged in the unit may differ.

(4) Unit operating at nominal operating capacity, without any accessories, with external air temperature of 35°C and user-side heat exchanger water inlet-outlet temperature of 12-7°C. Binding values. Values obtained from measures taken according to standard ISO 3744 and to the Eurovent certification programme where applicable.

(5) Unit operating at nominal operating capacity, without any accessories, with external air temperature of 7°C (6°C wb) and user-side heat exchanger water inlet-outlet temperature of 40-45°C. Values obtained from measures taken according to standard ISO 3744.

(6) Values obtained from the sound power level (conditions: note 4), related to a distance of 10m from the unit in free field with directivity factor Q=2. Non-binding values.

(7) Approximate value. The minimum capacity reached by the unit depends on the operating conditions. The value shown may not be suitable for calculating the minimum volume of water: to do this, consult the "Minimum water content in the system" section.

** Basic CH unit without included accessories

ZETA REV HE

			3.2	4.2	5.2	6.2	7.2	8.2	9.2
ZETA REV HE									
Cooling									
Refrigeration capacity	(1)	kW	42,4	49,2	58,2	63,3	72,2	87,2	100,7
Total absorbed power	(1)	kW	13,1	15,4	18,7	19,4	22,6	27,5	32,1
EER	(1)		3,25	3,20	3,11	3,26	3,19	3,17	3,13
Eurovent efficiency class	(1)		A	A	A	A	A	A	A
ESEER			4,39	4,35	4,37	4,48	4,36	4,26	4,30
ZETA REV HE /HP									
Cooling									
Refrigeration capacity	(1)	kW	42,5	50,6	57,8	62,5	71,2	86,1	100,3
Total absorbed power	(1)	kW	13,7	16,3	18,6	19,6	22,8	27,6	32,3
EER	(1)		3,10	3,10	3,10	3,18	3,12	3,11	3,10
Eurovent efficiency class	(1)		A	A	A	A	A	A	A
ESEER			4,29	4,30	4,37	4,42	4,32	4,22	4,29
Heating									
Heating capacity	(2)	kW	44,1	51,2	59,2	67,1	74,8	91,4	102,6
Total absorbed power	(2)	kW	13,3	15,3	17,7	20,0	22,3	27,5	31,0
COP	(2)		3,31	3,35	3,35	3,35	3,35	3,32	3,31
Eurovent efficiency class	(2)		A	A	A	A	A	A	A
Compressors									
Compressors/Circuits		n°/n°	2/1	2/1	2/1	2/1	2/1	2/1	2/1
Minimum capacity reduction step	(7)	%	50%	50%	50%	50%	50%	50%	43%
Refrigerant charge CH (MCHX)	(3)	kg	5,9	6,2	6,2	9,8	9,8	9,8	10,2
Refrigerant charge HP	(3)	kg	12,5	12,8	17,2	27,6	27,6	27,6	27,8
Fans									
Quantity		n°	2	2	2	3	3	2	2
Total air flow rate CH (MCHX)		m³/h	19.000	19.000	19.000	28.000	28.000	39.000	39.000
Total air flow rate HP		m³/h	18.000	18.000	18.000	26.000	26.000	36.000	36.000
User-side heat exchanger									
Quantity		n°	1	1	1	1	1	1	1
Water flow rate CH	(1)	m³/h	7,3	8,5	10,1	10,9	12,5	15,1	17,4
Pressure drop CH	(1)	kPa	25,0	22,6	28,2	27,1	32,9	44,4	40,9
Water flow rate HP	(1)	m³/h	7,3	8,7	10,0	10,8	12,3	14,9	17,3
Pressure drop HP	(1)	kPa	22,7	20,5	27,6	25,9	31,4	42,8	39,3
Noise levels									
Sound power level cooling	(4)	dB(A)	78	79	79	80	81	82	83
Sound power level heating	(5)	dB(A)	78	79	79	80	81	82	83
Sound pressure level cooling	(6)	dB(A)	46	48	48	48	49	50	51
Sound power level of vers. LN cooling	(4)	dB(A)	76	77	77	78	79	80	81
Sound power level of vers. LN heating	(5)	dB(A)	76	77	77	78	79	80	81
Sound pressure level of vers. LN cooling	(6)	dB(A)	44	46	46	46	47	48	49
Dimensions and weights**									
Length		mm	1.750	1.750	2.200	3.200	3.200	3.200	3.200
Depth		mm	1.000	1.000	1.000	1.100	1.100	1.100	1.100
Height		mm	1.400	1.400	1.740	1.740	1.740	1.880	1.880
Operating weight		kg	450	461	659	857	867	977	1.053

CH: chiller unit; HP: heat pump unit; MCHX: unit with microchannel coils

(1) External air temperature 35°C, user-side heat exchanger water inlet/outlet temperature 12/7°C. Values in accordance with EN 14511.

(2) Outside air temperature 7°C DB, 6°C WB; condenser inlet/outlet water temperature 40/45°C. Values in accordance with EN 14511.

(3) Theoretical values referred to the basic unit. The amount of gas actually charged in the unit may differ.

(4) Unit operating at nominal operating capacity, without any accessories, with external air temperature of 35°C and user-side heat exchanger water inlet-outlet temperature of 12-7°C. Binding values. Values obtained from measures taken according to standard ISO 3744 and to the Eurovent certification programme where applicable.

(5) Unit operating at nominal operating capacity, without any accessories, with external air temperature of 7°C (6°C wb) and user-side heat exchanger water inlet-outlet temperature of 40-45°C. Values obtained from measures taken according to standard ISO 3744.

(6) Values obtained from the sound power level (conditions: note 4), related to a distance of 10m from the unit in free field with directivity factor Q=2. Non-binding values.

(7) Approximate value. The minimum capacity reached by the unit depends on the operating conditions. The value shown may not be suitable for calculating the minimum volume of water: to do this, consult the "Minimum water content in the system" section.

** Basic CH unit without included accessories

ZETA REV HE

			10.2	12.2	13.2	14.4	15.2	16.2	16.4
ZETA REV HE									
Cooling									
Refrigeration capacity	(1)	kW	110,9	127,7	139,0	144,5	158,7	179,5	171,2
Total absorbed power	(1)	kW	35,2	40,8	43,3	50,2	57,4	45,5	54,5
EER	(1)		3,15	3,13	3,21	3,18	3,16	3,13	3,14
Eurovent efficiency class	(1)		A	A	A	A	A	A	A
ESEER			4,22	4,23	4,27	4,30	4,26	4,24	4,26
ZETA REV HE /HP									
Cooling									
Refrigeration capacity	(1)	kW	111,2	128,5	139,6	145,0	160,3	183,0	172,9
Total absorbed power	(1)	kW	35,8	41,5	44,3	51,4	59,0	46,6	55,7
EER	(1)		3,11	3,10	3,15	3,11	3,12	3,10	3,10
Eurovent efficiency class	(1)		A	A	A	A	A	A	A
ESEER			4,21	4,22	4,23	4,28	4,24	4,22	4,25
Heating									
Heating capacity	(2)	kW	114,9	129,7	147,7	154,3	166,5	185,0	177,8
Total absorbed power	(2)	kW	34,6	38,7	44,4	50,0	55,4	46,1	53,1
COP	(2)		3,32	3,35	3,32	3,35	3,33	3,34	3,35
Eurovent efficiency class	(2)		A	A	A	A	A	A	A
Compressors									
Compressors/Circuits		n°/n°	2/1	2/1	2/1	4/2	2/1	2/1	4/2
Minimum capacity reduction step	(7)	%	50%	44%	50%	45%	50%	25%	25%
Refrigerant charge CH (MCHX)	(3)	kg	15,2	15,8	24,0	24,0	25,2	24,6	24,6
Refrigerant charge HP	(3)	kg	40,9	41,2	54,8	54,8	55,4	56,6	56,6
Fans									
Quantity		n°	2	2	3	3	3	3	3
Total air flow rate CH (MCHX)		m³/h	42.000	42.000	63.000	63.000	63.000	63.000	63.000
Total air flow rate HP		m³/h	40.000	40.000	58.000	58.000	58.000	58.000	58.000
User-side heat exchanger									
Quantity		n°	1	1	1	1	1	2	2
Water flow rate CH	(1)	m³/h	19,2	22,1	24,0	27,4	31,0	25,0	29,6
Pressure drop CH	(1)	kPa	51,7	48,2	41,5	50,1	46,8	34,1	42,8
Water flow rate HP	(1)	m³/h	19,2	22,2	24,1	27,7	31,6	25,0	29,9
Pressure drop HP	(1)	kPa	49,0	45,6	39,1	47,0	43,4	31,9	40,1
Noise levels									
Sound power level cooling	(4)	dB(A)	84	86	87	84	87	87	85
Sound power level heating	(5)	dB(A)	84	86	87	84	87	87	85
Sound pressure level cooling	(6)	dB(A)	52	54	55	52	55	55	53
Sound power level of vers. LN cooling	(4)	dB(A)	82	84	85	82	85	85	83
Sound power level of vers. LN heating	(5)	dB(A)	82	84	85	82	85	85	83
Sound pressure level of vers. LN cooling	(6)	dB(A)	50	52	53	50	53	53	51
Dimensions and weights**									
Length		mm	3.200	3.200	4.200	4.200	4.200	4.200	4.200
Depth		mm	1.100	1.100	1.100	1.100	1.100	1.100	1.100
Height		mm	2.380	2.380	2.380	2.380	2.380	2.380	2.380
Operating weight		kg	1.294	1.350	1.571	1.532	1.613	1.636	1.554

CH: chiller unit; HP: heat pump unit; MCHX: unit with microchannel coils

(1) External air temperature 35°C, user-side heat exchanger water inlet/outlet temperature 12/7°C. Values in accordance with EN 14511.

(2) Outside air temperature 7°C DB, 6°C WB; condenser inlet/outlet water temperature 40/45°C. Values in accordance with EN 14511.

(3) Theoretical values referred to the basic unit. The amount of gas actually charged in the unit may differ.

(4) Unit operating at nominal operating capacity, without any accessories, with external air temperature of 35°C and user-side heat exchanger water inlet-outlet temperature of 12-7°C. Binding values. Values obtained from measures taken according to standard ISO 3744 and to the Eurovent certification programme where applicable.

(5) Unit operating at nominal operating capacity, without any accessories, with external air temperature of 7°C (6°C wb) and user-side heat exchanger water inlet-outlet temperature of 40-45°C. Values obtained from measures taken according to standard ISO 3744.

(6) Values obtained from the sound power level (conditions: note 4), related to a distance of 10m from the unit in free field with directivity factor Q=2. Non-binding values.

(7) Approximate value. The minimum capacity reached by the unit depends on the operating conditions. The value shown may not be suitable for calculating the minimum volume of water: to do this, consult the "Minimum water content in the system" section.

** Basic CH unit without included accessories

ZETA REV SLN

			3.2	4.2	5.2	6.2	7.2	8.2	9.2
ZETA REV SLN									
Cooling									
Refrigeration capacity	(1)	kW	39,2	44,2	50,0	60,0	68,0	81,3	91,8
Total absorbed power	(1)	kW	13,8	16,6	19,8	20,2	23,6	27,3	32,1
EER	(1)		2,77	2,58	2,44	2,90	2,81	2,92	2,79
Eurovent efficiency class	(1)		C	D	E	B	C	B	C
ESEER			4,05	4,05	3,96	4,21	4,14	4,14	4,19
ZETA REV SLN /HP									
Cooling									
Refrigeration capacity	(1)	kW	42,5	50,6	57,8	62,5	71,2	86,1	100,3
Total absorbed power	(1)	kW	14,2	17,2	20,5	20,7	24,2	27,8	32,9
EER	(1)		3,10	3,10	3,10	3,18	3,12	3,11	3,10
Eurovent efficiency class	(1)		A	A	A	A	A	A	A
ESEER			4,29	4,30	4,37	4,42	4,32	4,22	4,29
Heating									
Heating capacity	(2)	kW	44,1	51,2	59,2	67,1	74,8	91,4	102,6
Total absorbed power	(2)	kW	13,3	15,3	17,7	20	22,3	27,5	31
COP	(2)		3,31	3,35	3,35	3,35	3,35	3,32	3,31
Eurovent efficiency class	(2)		A	A	A	A	A	A	A
Compressors									
Compressors/Circuits		n°/n°	2/1	2/1	2/1	2/1	2/1	2/1	2/1
Minimum capacity reduction step	(7)	%	50%	50%	50%	50%	50%	50%	43%
Refrigerant charge CH (MCHX)	(3)	kg	5,9	6,2	6,2	9,8	9,8	9,8	10,2
Refrigerant charge HP	(3)	kg	12,5	12,8	17,2	27,6	27,6	27,6	27,8
Fans									
Quantity		n°	2	2	2	3	3	2	2
Total air flow rate CH (MCHX)		m³/h	19.000	19.000	19.000	28.000	28.000	39.000	39.000
Total air flow rate HP		m³/h	18.000	18.000	18.000	26.000	26.000	36.000	36.000
User-side heat exchanger									
Quantity		n°	1	1	1	1	1	1	1
Water flow rate CH	(1)	m³/h	7,3	8,5	10,1	10,9	12,5	15,1	17,4
Pressure drop CH	(1)	kPa	25,0	22,6	28,2	27,1	32,9	44,4	40,9
Water flow rate HP	(1)	m³/h	7,3	8,7	10,0	10,8	12,3	14,9	17,3
Pressure drop HP	(1)	kPa	22,7	20,5	27,6	25,9	31,4	42,8	39,3
Noise levels									
Sound power level cooling	(4)	dB(A)	74	75	75	76	77	78	79
Sound power level heating	(5)	dB(A)	76	77	77	78	79	80	81
Sound pressure level cooling	(6)	dB(A)	42	44	44	44	45	46	47
Dimensions and weights**									
Length		mm	2.200	2.200	2.200	3.200	3.200	3.200	3.200
Depth		mm	1.000	1.000	1.000	1.100	1.100	1.100	1.100
Height		mm	1.740	1.740	1.740	1.740	1.740	1.880	1.880
Operating weight		kg	537	548	550	706	715	823	903

CH: chiller unit; HP: heat pump unit; MCHX: unit with microchannel coils

(1) External air temperature 35°C, user-side heat exchanger water inlet/outlet temperature 12/7°C. Values in accordance with EN 14511.

(2) Outside air temperature 7°C DB, 6°C WB; condenser inlet/outlet water temperature 40/45°C. Values in accordance with EN 14511.

(3) Theoretical values referred to the basic unit. The amount of gas actually charged in the unit may differ.

(4) Unit operating at nominal operating capacity, without any accessories, with external air temperature of 35°C and user-side heat exchanger water inlet-outlet temperature of 12-7°C. Binding values. Values obtained from measures taken according to standard ISO 3744 and to the Eurovent certification programme where applicable.

(5) Unit operating at nominal operating capacity, without any accessories, with external air temperature of 7°C (6°C wb) and user-side heat exchanger water inlet-outlet temperature of 40-45°C. Values obtained from measures taken according to standard ISO 3744.

(6) Values obtained from the sound power level (conditions: note 4), related to a distance of 10m from the unit in free field with directivity factor Q=2. Non-binding values.

(7) Approximate value. The minimum capacity reached by the unit depends on the operating conditions. The value shown may not be suitable for calculating the minimum volume of water: to do this, consult the "Minimum water content in the system" section.

** Basic CH unit without included accessories

ZETA REV SLN

			10.2	12.2	13.2	14.4	15.2	16.2	16.4
ZETA REV SLN									
Cooling									
Refrigeration capacity	(1)	kW	102,2	112,2	131,9	137,3	148,0	163,1	157,1
Total absorbed power	(1)	kW	36,2	42,3	44,3	51,7	59,9	47,1	57,0
EER	(1)		2,75	2,58	2,92	2,88	2,80	2,66	2,72
Eurovent efficiency class	(1)		C	D	B	C	C	D	C
ESEER			4,10	3,90	4,07	4,21	4,05	3,97	4,13
ZETA REV SLN /HP									
Cooling									
Refrigeration capacity	(1)	kW	111,2	128,5	139,6	145,0	160,3	183,0	172,9
Total absorbed power	(1)	kW	37,1	43,5	45,2	52,9	61,3	47,7	57,8
EER	(1)		3,11	3,10	3,15	3,11	3,12	3,10	3,10
Eurovent efficiency class	(1)		A	A	A	A	A	A	A
ESEER			4,21	4,22	4,23	4,28	4,24	4,22	4,25
Heating									
Heating capacity	(2)	kW	114,9	129,7	147,7	154,3	166,5	185,0	177,8
Total absorbed power	(2)	kW	34,6	38,7	44,4	50	55,4	46,1	53,1
COP	(2)		3,32	3,35	3,32	3,35	3,33	3,34	3,35
Eurovent efficiency class	(2)		A	A	A	A	A	A	A
Compressors									
Compressors/Circuits		n°/n°	2/1	2/1	2/1	4/2	2/1	2/1	4/2
Minimum capacity reduction step	(7)	%	50%	44%	50%	45%	50%	25%	25%
Refrigerant charge CH (MCHX)	(3)	kg	15,2	15,8	24,0	24,0	25,2	24,6	24,6
Refrigerant charge HP	(3)	kg	40,9	41,2	54,8	54,8	55,4	56,6	56,6
Fans									
Quantity		n°	2	2	3	3	3	3	3
Total air flow rate CH (MCHX)		m³/h	42.000	42.000	63.000	63.000	63.000	63.000	63.000
Total air flow rate HP		m³/h	40.000	40.000	58.000	58.000	58.000	58.000	58.000
User-side heat exchanger									
Quantity		n°	1	1	1	1	1	2	2
Water flow rate CH	(1)	m³/h	19,2	22,1	24,0	27,4	31,0	25,0	29,6
Pressure drop CH	(1)	kPa	51,7	48,2	41,5	50,1	46,8	34,1	42,8
Water flow rate HP	(1)	m³/h	19,2	22,2	24,1	27,7	31,6	25,0	29,9
Pressure drop HP	(1)	kPa	49,0	45,6	39,1	47,0	43,4	31,9	40,1
Noise levels									
Sound power level cooling	(4)	dB(A)	80	82	83	80	83	83	81
Sound power level heating	(5)	dB(A)	82	84	85	82	85	85	83
Sound pressure level cooling	(6)	dB(A)	48	50	51	48	51	51	49
Dimensions and weights**									
Length		mm	3.200	3.200	4.200	4.200	4.200	4.200	4.200
Depth		mm	1.100	1.100	1.100	1.100	1.100	1.100	1.100
Height		mm	2.380	2.380	2.380	2.380	2.380	2.380	2.380
Operating weight		kg	1.128	1.154	1.458	1.414	1.477	1.506	1.420

CH: chiller unit; HP: heat pump unit; MCHX: unit with microchannel coils

(1) External air temperature 35°C, user-side heat exchanger water inlet/outlet temperature 12/7°C. Values in accordance with EN 14511.

(2) Outside air temperature 7°C DB, 6°C WB; condenser inlet/outlet water temperature 40/45°C. Values in accordance with EN 14511.

(3) Theoretical values referred to the basic unit. The amount of gas actually charged in the unit may differ.

(4) Unit operating at nominal operating capacity, without any accessories, with external air temperature of 35°C and user-side heat exchanger water inlet-outlet temperature of 12-7°C. Binding values. Values obtained from measures taken according to standard ISO 3744 and to the Eurovent certification programme where applicable.

(5) Unit operating at nominal operating capacity, without any accessories, with external air temperature of 7°C (6°C wb) and user-side heat exchanger water inlet-outlet temperature of 40-45°C. Values obtained from measures taken according to standard ISO 3744.

(6) Values obtained from the sound power level (conditions: note 4), related to a distance of 10m from the unit in free field with directivity factor Q=2. Non-binding values.

(7) Approximate value. The minimum capacity reached by the unit depends on the operating conditions. The value shown may not be suitable for calculating the minimum volume of water: to do this, consult the "Minimum water content in the system" section.

** Basic CH unit without included accessories

ZETA REV LE

			3.2	4.2	5.2	6.2	7.2	8.2	9.2	10.2	12.2
ZETA REV LE											
Cooling											
Refrigeration capacity	(1)	kW	45,7	51,2	58,1	67,5	73,5	92,1	104,5	115,2	131,2
Total absorbed power	(1)	kW	14,3	17,3	21,0	21,3	25,3	27,3	32,5	37,8	43,2
EER	(1)		3,21	2,96	2,77	3,17	2,9	3,38	3,22	3,05	3,03
ZETA REV LE /HP											
Cooling											
Refrigeration capacity	(1)	kW	45,3	50,8	59,4	66,7	72,6	92,3	102,2	110,8	128,9
Total absorbed power	(1)	kW	14,6	17,8	20,7	21,9	26,0	28,2	33,8	40,2	44,8
EER	(1)		3,1	2,86	2,88	3,04	2,8	3,28	3,02	2,76	2,88
Heating											
Heating capacity	(2)	kW	42,4	46,7	55,3	64,7	71,9	87,4	96,3	103,9	122,9
Total absorbed power	(2)	kW	11,0	12,4	14,2	15,8	17,7	21,3	24,1	26,9	32,0
COP	(2)		3,85	3,76	3,89	4,08	4,06	4,11	3,99	3,86	3,85
Compressors											
Compressors/Circuits		n°/n°	2/1	2/1	2/1	2/1	2/1	2/1	2/1	2/1	2/1
Minimum capacity reduction step	(7)	%	50%	50%	50%	50%	50%	50%	43%	50%	44%
Fans											
Quantity		n°	2	2	2	2	2	3	3	3	2
Total air flow rate CH (MCHX)		m³/h	18.000	18.000	17.000	19.000	19.000	28.000	28.000	28.000	39.000
Total air flow rate HP		m³/h	16.000	16.000	15.000	18.000	18.000	26.000	26.000	26.000	36.000
Noise levels											
Sound power level cooling	(4)	dB(A)	78	79	79	80	81	82	83	84	86
Sound power level heating	(5)	dB(A)	78	79	79	80	81	82	83	84	86
Sound pressure level cooling	(6)	dB(A)	46	48	48	48	49	50	51	52	54
Sound power level of vers. LN cooling	(4)	dB(A)	76	77	77	78	79	80	81	82	84
Sound power level of vers. LN heating	(5)	dB(A)	76	77	77	78	79	80	81	82	84
Sound pressure level of vers. LN cooling	(6)	dB(A)	44	46	46	46	47	48	49	50	52
Dimensions and weights**											
Length		mm	1.750	1.750	1.750	2.200	2.200	3.200	3.200	3.200	3.200
Depth		mm	1.000	1.000	1.000	1.000	1.000	1.100	1.100	1.100	1.100
Height		mm	1.400	1.400	1.400	1.740	1.740	1.740	1.740	1.740	1.880
Operating weight		kg	399	407	413	534	548	767	772	780	926

Partly completed machinery: conformity with Ecodesign depends on the combination with the remote heat exchanger. CE marked units.

CH: chiller unit; HP: heat pump unit; MCHX: unit with microchannel coils

(1) External air temperature 35°C, evaporating temperature 7.5°C.

(2) External air temperature 7°C DB, 6°C WB, condensing temperature 40°C.

(4) unit operating at nominal operating capacity, without any accessories, with external air temperature of 35°C and evaporating temperature 7.5°C. Binding values. Values obtained from measures taken according to standard ISO 3744 and to the Eurovent certification programme where applicable.

(5) unit operating at nominal operating capacity, without any accessories, with external air temperature of 7°C (6°C wb) and condensing temperature 40°C. Values obtained from measures taken according to standard ISO 3744.

(6) Values obtained from the sound power level (conditions: note 4), related to a distance of 10m from the unit in free field with directivity factor Q=2. Non-binding values.

(7) Approximate value. The minimum capacity reached by the unit depends on the operating conditions. The value shown may not be suitable for calculating the minimum volume of water: to do this, consult the "Minimum water content in the system" section.

** Basic CH unit without included accessories

ZETA REV LE

			13.2	15.2	16.2	14.4	16.4	18.4	20.4	24.4
ZETA REV LE										
Cooling										
Refrigeration capacity	(1)	kW	140,4	164,4	177,7	153	171	209,9	235	263,2
Total absorbed power	(1)	kW	49,8	55,3	64,9	49,4	60,6	64,6	75,3	86,3
EER	(1)		2,82	2,97	2,74	3,09	2,82	3,25	3,12	3,05
ZETA REV LE /HP										
Cooling										
Refrigeration capacity	(1)	kW	138,1	158,8	168,8	148,3	165,2	206,4	224,4	252,4
Total absorbed power	(1)	kW	51,3	58,1	68,0	51,8	63,5	68,3	80,7	91,7
EER	(1)		2,69	2,73	2,48	2,86	2,6	3,02	2,78	2,75
Heating										
Heating capacity	(2)	kW	133	154,8	167,9	145	163	196	212,9	237,1
Total absorbed power	(2)	kW	35,3	39,7	44,1	36,4	42,2	49,8	55,4	63,8
COP	(2)		3,77	3,89	3,81	3,98	3,86	3,94	3,84	3,72
Compressors										
Compressors/Circuits		n°/n°	2/1	2/1	2/1	4/2	4/2	4/2	4/2	4/2
Minimum capacity reduction step	(7)	%	50%	45%	50%	25%	25%	21%	25%	22%
Fans										
Quantity		n°	2	2	2	2	2	3	3	4
Total air flow rate CH (MCHX)		m³/h	39.000	42.000	42.000	42.000	42.000	63.000	63.000	76.000
Total air flow rate HP		m³/h	36.000	40.000	40.000	40.000	40.000	58.000	58.000	70.000
Noise levels										
Sound power level cooling	(4)	dB(A)	87	87	87	84	85	87	89	90
Sound power level heating	(5)	dB(A)	87	87	87	84	85	87	89	90
Sound pressure level cooling	(6)	dB(A)	55	55	55	52	53	55	57	58
Sound power level of vers. LN cooling	(4)	dB(A)	85	85	85	82	83	85	87	88
Sound power level of vers. LN heating	(5)	dB(A)	85	85	85	82	83	85	87	88
Sound pressure level of vers. LN cooling	(6)	dB(A)	53	53	53	50	51	53	55	56
Dimensions and weights**										
Length		mm	3.200	3.200	3.200	3.200	3.200	4.200	4.200	4.200
Depth		mm	1.100	1.100	1.100	1.100	1.100	1.100	1.100	1.100
Height		mm	1.880	2.380	2.380	2.380	2.380	2.380	2.380	2.380
Operating weight		kg	960	1104	1136	1102	1250	1529	1547	1671

Partly completed machinery: conformity with Ecodesign depends on the combination with the remote heat exchanger. CE marked units.

CH: chiller unit; HP: heat pump unit; MCHX: unit with microchannel coils

(1) External air temperature 35°C, evaporating temperature 7.5°C.

(2) External air temperature 7°C DB, 6°C WB, condensing temperature 40°C.

(4) unit operating at nominal operating capacity, without any accessories, with external air temperature of 35°C and evaporating temperature 7.5°C. Binding values. Values obtained from measures taken according to standard ISO 3744 and to the Eurovent certification programme where applicable.

(5) unit operating at nominal operating capacity, without any accessories, with external air temperature of 7°C (6°C wb) and condensing temperature 40°C. Values obtained from measures taken according to standard ISO 3744.

(6) Values obtained from the sound power level (conditions: note 4), related to a distance of 10m from the unit in free field with directivity factor Q=2. Non-binding values.

(7) Approximate value. The minimum capacity reached by the unit depends on the operating conditions. The value shown may not be suitable for calculating the minimum volume of water: to do this, consult the "Minimum water content in the system" section.

** Basic CH unit without included accessories

ECODESIGN

INTRODUCTION

The Ecodesign/ErP Directive (2009/125/EC) lays down new standards for more efficient energy use.

The Directive contains various regulations; as regards chiller products and heat pumps, the regulations of interest are the following:

- Regulation 2013/813, for small heat pumps ($P_{\text{design}} \leq 400$ kW)
- Regulation 2016/2281, for chillers and heat pumps with $P_{\text{design}} > 400$ kW
- Regulation 2013/811, for heat pumps with $P_{\text{design}} \leq 70$ kW.

The last-mentioned regulation (2013/811) regards the labelling (Ecolabel certification) of small heat pumps.

The other two regulations (2013/813 and 2016/2281) set seasonal efficiency targets that the products must comply with to be sold and installed in the European Union (essential requirement for CE marking).

These efficiency limits are defined through ratios, which are respectively:

- η_{sh} (SCOP), with reference to regulation 2013/813
- η_{sc} (SEER) for comfort applications and SEPR for process applications, with reference to regulation 2016/2281.

As regards regulation 2016/2281, with effect from 1st January 2021, the required minimum efficiency limit will be raised (Tier 2) from the current threshold (Tier 1).

The figure below schematically illustrates the correspondence between product and reference energy ratio.

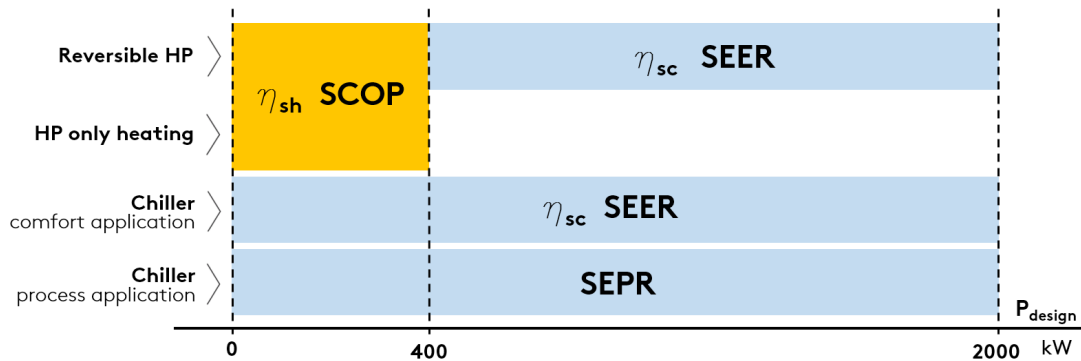

Some notes and clarifications:

For comfort applications, regulation 2016/2281 sets the η_{sc} (SEER) ratio in two different operating conditions:

- SEER calculated with machine inlet/outlet water temperature of 12/7°C (low temperature application),
- SEER calculated with machine inlet/outlet water temperature of 23/18°C (medium temperature application).

The minimum efficiency requirement is the same, but can be met at condition 12/7°C or at condition 23/18°C, depending on the application envisaged for the machine.

Regulation 2013/813 distinguishes two different types: at low temperature and at medium temperature.

The following refer to the application at low temperature: (low temperature application) all heat pumps whose maximum delivery temperature for heating purposes is lower than 52°C with source at temperature of -7°C and -8°C wet bulb (air-water unit) or inlet 10°C (water-water unit), at the reference design conditions for an average climate. For these, the efficiency ratio is "low temperature application" (outlet water temperature 35°C).

For all the other heat pumps, the efficiency ratio is related to "medium temperature application" (outlet water temperature 55°C).

The ratios must be calculated according to the reference European heating season in average climatic conditions.

The minimum efficiency requirements set by the regulations are indicated below.

REGULATION 2016/2281, comfort application

TYPE OF UNIT		MINIMUM REQUIREMENT			
		Tier 1		Tier 2 (2021)	
SOURCE	P _{design}	η_{sc} [%]	SEER	η_{sc} [%]	SEER
air	< 400kW	149	3,8	161	4,1
air	\geq 400kW	161	4,1	179	4,55
water	< 400kW	196	5,1	200	5,2
water	\geq 400kW and < 1500kW	227	5,875	252	6,5
water	\geq 1500kW	245	6,325	272	7

REGULATION 2016/2281, process application

TYPE OF UNIT		MINIMUM REQUIREMENT	
		Tier 1	Tier 2 (2021)
SOURCE	P _{design}	SEPR	SEPR
air	< 400kW	4,5	5
air	\geq 400kW	5	5,5
water	< 400kW	6,5	7
water	\geq 400kW and < 1500kW	7,5	8
water	\geq 1500kW	8	8,5

REGULATION 2013/813

SOURCE	APPLICATION	MINIMUM REQUIREMENT	
		η_{sh} [%]	SCOP
air	low temperature application	125	3,2
air	low temperature application	125	3,325
water	medium temperature application	110	2,825
water	medium temperature application	110	2,95

The conformity of the product must be checked according to the type of application, whether comfort or process, and at the required outlet water temperature.

The two schematic tables below, respectively for comfort application and for process application, indicate the reference of the required conformity according to the type of product and the set point temperature (reference to regulations 2016/2281 and 2013/813).

Important note: for mixed comfort and process applications, the reference application for conformity is the comfort application.

COMFORT APPLICATION

PRODUCT	OUTLET WATER TEMPERATURE	COMPLIANCE INDEX	REGULATION
Chiller	< 18°C	SEER/ηsc low temperature application	2016/2283
	≥ 18°C	SEER/ηsc medium temperature application	2016/2283
Heat pumps (reversible and only heating) Pdesign≤400kW		SCOP/ηsh	2013/815
Reversible heat pumps Pdesign>400kW	< 18°C	SEER/ηsc low temperature application	2016/2283
	≥ 18°C	SEER/ηsc medium temperature application	2016/2283
Heat pumps only heating Pdesign>400kW		-	-

- = exemption from Ecodesign

PROCESS APPLICATION

PRODUCT	OUTLET WATER TEMPERATURE	COMPLIANCE INDEX	REGULATION
Chiller	≥ +2°C , ≤ 12°C	SEPR	2016/2283
	> 12°C	-	-
	> -8°C , < +2°C	-	-

- = exemption from Ecodesign

Some specifications and notes follow.

Partly completed machinery

The term partly completed machinery refers to all units without a user-side or source-side heat exchanger, and therefore to all LC, LE, LC/HP and LE/HP versions. Since these are "non-complete" machines, conformity with Ecodesign depends on combination with the remote heat exchanger.

All the partly completed machinery is CE marked and accompanied by a declaration of conformity. Installation in European Union countries is therefore allowed; correct selection and installation of the remote heat exchanger must be ensured, in accordance with the above cases.

EC fans:

The only option that positively affects the performance of the unit, by increasing its seasonal energy efficiency ratio, is the VEC accessory.

A unit equipped with EC fans has a higher SEER (ηsc) than the configuration with standard fans.

ZETA REV RANGE

As specifically regards the Zeta Rev range, the regulations of interest for the various units in various configurations are indicated below.

Zeta Rev:

- chiller version: regulation 2016/2281
- /HP version: regulation 2016/2281 (since they are all units with $P_{design} \leq 400$ kW).

Zeta Rev HE and Zeta Rev SLN:

- chiller version: regulation 2016/2281
- /HP version: regulation 2013/813 (since they are all units with $P_{design} \leq 400$ kW).

Zeta Rev LE:

Since these are partly completed machines, conformity with Ecodesign depends on combination with the remote heat exchanger.

All LE units are CE marked.

The tables below give information on the conformity of the units and the seasonal energy performance ratios with regard to the reference regulation.

ZETA REV

			3.2	4.2	5.2	6.2	7.2	8.2	9.2	10.2	12.2
REGULATION 2016/2281											
Pdesign	(1)	kW	40,4	45,3	52,9	59,6	66,7	80,9	92,8	101,9	116,2
Compliance 12/7											
Compliance	(1)		N	N	N	Y	Y	Y	Y	Y	Y
η_{sc}	(1)	%	N	N	N	152,2	151,0	149,3	150,1	149,9	149,0
SEER	(1)		N	N	N	3,88	3,85	3,81	3,83	3,82	3,80
Compliance Tier 2 (2021)	(1)		N	N	N	N	N	N	N	N	N
Compliance 12/7 unit with EC fans											
Compliance	(1)		Y	Y	Y	Y	Y	Y	Y	Y	Y
η_{sc}	(1)	%	149,1	149,1	149,0	155,1	152,9	155,5	157,7	154,9	151,2
SEER	(1)		3,80	3,80	3,80	3,95	3,90	3,96	4,02	3,95	3,85
Compliance Tier 2 (2021)	(1)		N	N	N	N	N	N	N	N	N
Compliance 23/18											
Compliance	(2)		Y	Y	Y	Y	Y	Y	Y	Y	Y
η_{sc}	(2)	%	170,3	163,3	165,9	-	-	-	-	-	-
SEER	(2)		4,33	4,16	4,22	-	-	-	-	-	-
Compliance SEPR											
Compliance	(3)		Y	Y	Y	Y	Y	Y	Y	Y	Y
SEPR	(3)		5,66	5,38	5,3	5,53	5,24	5,53	5,54	5,33	5,09

			13.2	14.4	15.2	16.2	16.4	18.4	20.4	24.4	
REGULATION 2016/2281											
Pdesign	(1)	kW	125,1	136,8	146,2	159,1	153,4	189,3	207,7	233,3	
Compliance 12/7											
Compliance	(1)		N	Y	Y	N	Y	Y	Y	Y	
η_{sc}	(1)	%	N	149,4	151,6	N	149,1	154,1	150,8	149,1	
SEER	(1)		N	3,81	3,87	N	3,80	3,93	3,84	3,80	
Compliance Tier 2 (2021)	(1)		N	N	N	N	N	N	N	N	
Compliance 12/7 unit with EC fans											
Compliance	(1)		Y	Y	Y	Y	Y	Y	Y	Y	
η_{sc}	(1)	%	149,1	158,8	155,0	149,1	151,1	163,6	158,0	160,0	
SEER	(1)		3,80	4,05	3,95	3,80	3,85	4,17	4,03	4,07	
Compliance Tier 2 (2021)	(1)		N	N	N	N	N	Y	N	N	
Compliance 23/18											
Compliance	(2)		Y	Y	Y	Y	Y	Y	Y	Y	
η_{sc}	(2)	%	163,0	-	-	167,0	-	-	-	-	
SEER	(2)		4,15	-	-	4,25	-	-	-	-	
Compliance SEPR											
Compliance	(3)		Y	Y	Y	Y	Y	Y	Y	Y	
SEPR	(3)		5,17	5,23	5,2	5,1	5,03	5,42	5,22	5,05	

Y = unit in compliance with Ecodesign at the indicated condition.

N = unit not in compliance with Ecodesign at the indicated condition: it can be installed only in non-EU countries.

- = value not necessary: conformity is already provided at the most restrictive condition (1).

(1) User-side heat exchanger water inlet/outlet temperature 12/7°C (low temperature application), with reference to regulation 2016/2281 and standard EN 14825.

(2) User-side heat exchanger water inlet/outlet temperature 23/18°C (medium temperature application), with reference to regulation 2016/2281 and standard EN 14825.

(3) User-side heat exchanger water inlet/outlet temperature 12/7°C, with reference to regulation 2016/2281 and norm EN 14825.

ZETA REV /HP

			3.2	4.2	5.2	6.2	7.2	8.2	9.2	10.2	12.2
REGULATION 2013/813											
Pdesign	(4)	kW	39,3	43,8	50,9	59,3	64,4	78,6	84,9	93,8	112,2
Compliance	(4)		Y	Y	Y	Y	Y	Y	Y	Y	Y
η_{sh}	(4)	%	129,8	133,1	136,4	135,4	139,3	134,6	136,2	135,2	128,6
SCOP	(4)		3,32	3,40	3,48	3,46	3,56	3,44	3,48	3,46	3,29
REGULATION 2013/811											
Ecolabel	(5)		A+	A+	A+	A+	A+	-	-	-	-

			13.2	14.4	15.2	16.2	16.4	18.4	20.4	24.4
REGULATION 2013/813										
Pdesign	(4)	kW	123,3	139,3	149,3	133,9	151,1	180,8	195,7	221,9
Compliance	(4)		Y	Y	Y	Y	Y	Y	Y	Y
η_{sh}	(4)	%	128,3	131,0	134,4	132,4	130,9	127,7	126,5	127,1
SCOP	(4)		3,28	3,35	3,44	3,39	3,35	3,27	3,24	3,25
REGULATION 2013/811										
Ecolabel	(5)		-	-	-	-	-	-	-	-

Y = unit in compliance with Ecodesign at the indicated condition.

(4) User-side heat exchanger water inlet/outlet temperature 30/35, Average climate profile, with reference to regulation 2013/813 and norm EN 14825.

(5) Energy efficiency class with reference to regulation 2013/811, note 4 conditions (low temperature applications).

ZETA REV HE

			3.2	4.2	5.2	6.2	7.2	8.2	9.2
REGULATION 2016/2281									
Pdesign	(1)	kW	42,4	49,2	58,2	63,3	72,2	87,2	100,7
Compliance 12/7									
Compliance	(1)		Y	Y	Y	Y	Y	Y	Y
η_{sc}	(1)	%	154,2	155,48	153,24	159,6	157,8	151,3	153,6
SEER	(1)		3,93	3,96	3,91	4,06	4,02	3,86	3,92
Compliance Tier 2 (2021)	(1)		N	N	N	N	N	N	N
Compliance 12/7 unit with EC fans									
Compliance	(1)		Y	Y	Y	Y	Y	Y	Y
η_{sc}	(1)	%	164,9	164,2	160,3	173,6	167,2	157,0	159,2
SEER	(1)		4,20	4,18	4,08	4,42	4,26	4,00	4,06
Compliance Tier 2 (2021)	(1)		Y	Y	N	Y	Y	N	N
Compliance 23/18									
Compliance	(2)		Y	Y	Y	Y	Y	Y	Y
η_{sc}	(2)	%	-	-	-	-	-	-	-
SEER	(2)		-	-	-	-	-	-	-
Compliance SEPR									
Compliance	(3)		Y	Y	Y	Y	Y	Y	Y
SEPR	(3)		6,01	5,92	5,93	6	5,68	5,5	5,54

			10.2	12.2	13.2	14.4	15.2	16.2	16.4
REGULATION 2016/2281									
Pdesign	(1)	kW	110,9	127,7	139,0	144,5	158,7	179,5	171,2
Compliance 12/7									
Compliance	(1)		Y	Y	Y	Y	Y	Y	Y
η_{sc}	(1)	%	151,0	151,9	155,2	153,7	157,8	152,52	150,6
SEER	(1)		3,85	3,87	3,96	3,92	4,02	3,89	3,84
Compliance Tier 2 (2021)	(1)		N	N	N	N	N	N	N
Compliance 12/7 unit with EC fans									
Compliance	(1)		Y	Y	Y	Y	Y	Y	Y
η_{sc}	(1)	%	159,6	157,2	163,8	173,4	165,8	163,5	165,2
SEER	(1)		4,07	4,01	4,17	4,41	4,22	4,16	4,20
Compliance Tier 2 (2021)	(1)		N	N	Y	Y	Y	Y	Y
Compliance 23/18									
Compliance	(2)		Y	Y	Y	Y	Y	Y	Y
η_{sc}	(2)	%	-	-	-	-	-	-	-
SEER	(2)		-	-	-	-	-	-	-
Compliance SEPR									
Compliance	(3)		Y	Y	Y	Y	Y	Y	Y
SEPR	(3)		5,51	5,51	5,4	5,51	5,54	5,49	5,27

Y = unit in compliance with Ecodesign at the indicated condition.

N = unit not in compliance with Ecodesign at the indicated condition: it can be installed only in non-EU countries.

- = value not necessary: conformity is already provided at the most restrictive condition (1).

(1) User-side heat exchanger water inlet/outlet temperature 12/7°C (low temperature application), with reference to regulation 2016/2281 and standard EN 14825.

(2) User-side heat exchanger water inlet/outlet temperature 23/18°C (medium temperature application), with reference to regulation 2016/2281 and standard EN 14825.

(3) User-side heat exchanger water inlet/outlet temperature 12/7°C, with reference to regulation 2016/2281 and norm EN 14825.

ZETA REV HE /HP

			3.2	4.2	5.2	6.2	7.2	8.2	9.2
REGULATION 2013/813									
Pdesign	(4)	kW	41,7	47,4	54	63,6	70,6	85,2	96,8
Compliance	(4)		Y	Y	Y	Y	Y	Y	Y
η_{sh}	(4)	%	134,1	137,8	140,4	139,6	139,3	127,7	132,0
SCOP	(4)		3,43	3,52	3,59	3,57	3,56	3,27	3,38
REGULATION 2013/811									
Ecolabel	(5)		A+	A+	A+	A+	-	-	-

			10.2	12.2	13.2	14.4	15.2	16.2	16.4
REGULATION 2013/813									
Pdesign	(4)	kW	108,9	120,3	138,6	156,9	171,8	148,2	169,4
Compliance	(4)		Y	Y	Y	Y	Y	Y	Y
η_{sh}	(4)	%	132,9	134,5	129,5	128,0	134,9	133,6	129,2
SCOP	(4)		3,40	3,44	3,31	3,28	3,45	3,42	3,31
REGULATION 2013/811									
Ecolabel	(5)		-	-	-	-	-	-	-

Y = unit in compliance with Ecodesign at the indicated condition.

(4) User-side heat exchanger water inlet/outlet temperature 30/35, Average climate profile, with reference to regulation 2013/813 and norm EN 14825.

(5) Energy efficiency class with reference to regulation 2013/811, note 4 conditions (low temperature applications).

ZETA REV SLN

			3.2	4.2	5.2	6.2	7.2	8.2	9.2
REGULATION 2016/2281									
Pdesign	(1)	kW	39,2	44,2	50,0	60,0	68,0	81,3	91,8
Compliance 12/7									
Compliance	(1)		Y	Y	Y	Y	Y	Y	Y
η_{sc}	(1)	%	151,0	150,2	149,1	156,4	153,7	149,9	152,1
SEER	(1)		3,85	3,83	3,80	3,99	3,92	3,82	3,88
Compliance Tier 2 (2021)	(1)		N	N	N	N	N	N	N
Compliance 12/7 unit with EC fans									
Compliance	(1)		Y	Y	Y	Y	Y	Y	Y
η_{sc}	(1)	%	162,8	163,0	159,1	171,6	166,0	155,8	157,2
SEER	(1)		4,14	4,15	4,05	4,36	4,22	3,97	4,01
Compliance Tier 2 (2021)	(1)		Y	Y	N	Y	Y	N	N
Compliance 23/18									
Compliance	(2)		Y	Y	Y	Y	Y	Y	Y
η_{sc}	(2)	%	-	-	-	-	-	-	-
SEER	(2)		-	-	-	-	-	-	-
Compliance SEPR									
Compliance	(3)		Y	Y	Y	Y	Y	Y	Y
SEPR	(3)		6,01	5,92	5,93	6	5,68	5,5	5,54

			10.2	12.2	13.2	14.4	15.2	16.2	16.4
REGULATION 2016/2281									
Pdesign	(1)	kW	102,2	112,2	131,9	137,3	148,0	163,1	157,1
Compliance 12/7									
Compliance	(1)		Y	Y	Y	Y	Y	Y	Y
η_{sc}	(1)	%	149,2	150,4	153,2	152,6	155,0	149,9	150,2
SEER	(1)		3,81	3,84	3,91	3,89	3,95	3,82	3,83
Compliance Tier 2 (2021)	(1)		N	N	N	N	N	N	N
Compliance 12/7 unit with EC fans									
Compliance	(1)		Y	Y	Y	Y	Y	Y	Y
η_{sc}	(1)	%	158,4	155,8	163,0	172,2	164,8	162,4	163,7
SEER	(1)		4,03	3,97	4,15	4,38	4,19	4,13	4,17
Compliance Tier 2 (2021)	(1)		N	N	Y	Y	Y	Y	Y
Compliance 23/18									
Compliance	(2)		Y	Y	Y	Y	Y	Y	Y
η_{sc}	(2)	%	-	-	-	-	-	-	-
SEER	(2)		-	-	-	-	-	-	-
Compliance SEPR									
Compliance	(3)		Y	Y	Y	Y	Y	Y	Y
SEPR	(3)		5,51	5,51	5,4	5,51	5,54	5,49	5,27

Y = unit in compliance with Ecodesign at the indicated condition.

N = unit not in compliance with Ecodesign at the indicated condition: it can be installed only in non-EU countries.

- = value not necessary: conformity is already provided at the most restrictive condition (1).

(1) User-side heat exchanger water inlet/outlet temperature 12/7°C (low temperature application), with reference to regulation 2016/2281 and standard EN 14825.

(2) User-side heat exchanger water inlet/outlet temperature 23/18°C (medium temperature application), with reference to regulation 2016/2281 and standard EN 14825.

(3) User-side heat exchanger water inlet/outlet temperature 12/7°C, with reference to regulation 2016/2281 and norm EN 14825.

ZETA REV SLN /HP

			3.2	4.2	5.2	6.2	7.2	8.2	9.2
REGULATION 2013/813									
Pdesign	(4)	kW	41,7	47,4	54	63,6	70,6	85,2	96,8
Compliance	(4)		Y	Y	Y	Y	Y	Y	Y
η_{sh}	(4)	%	134,1	137,8	140,4	139,6	139,3	127,7	132,0
SCOP	(4)		3,43	3,52	3,59	3,57	3,56	3,27	3,38
REGULATION 2013/811									
Ecolabel	(5)		A+	A+	A+	A+	-	-	-

			10.2	12.2	13.2	14.4	15.2	16.2	16.4
REGULATION 2013/813									
Pdesign	(4)	kW	108,9	120,3	138,6	156,9	171,8	148,2	169,4
Compliance	(4)		Y	Y	Y	Y	Y	Y	Y
η_{sh}	(4)	%	132,9	134,5	129,5	128,0	134,9	133,6	129,2
SCOP	(4)		3,40	3,44	3,31	3,28	3,45	3,42	3,31
REGULATION 2013/811									
Ecolabel	(5)		-	-	-	-	-	-	-

Y = unit in compliance with Ecodesign at the indicated condition.

(4) User-side heat exchanger water inlet/outlet temperature 30/35, Average climate profile, with reference to regulation 2013/813 and norm EN 14825.

(5) Energy efficiency class with reference to regulation 2013/811, note 4 conditions (low temperature applications).

ELECTRICAL SPECIFICATIONS

ZETA REV - ZETA REV LE

			3.2	4.2	5.2	6.2	7.2	8.2	9.2	10.2	12.2
General electrical specifications											
Max. absorbed power (FLI)	(1)	kW	18,3	21,4	24,5	27,2	30,5	35,7	41,4	47,0	54,2
Max. absorbed current (FLA)	(1)	A	37,6	47,2	49,2	55,2	67,2	75,9	81,9	87,9	97,1
Rated current (Inom)	(2)	A	32	36	41	44	49	62	66	71	76
cosφ standard unit	(2)		0,8	0,8	0,8	0,82	0,81	0,78	0,81	0,83	0,84
Nominal current with power factor correction (Inom)	(2)	A	28	30	34	37	42	52	56	61	67
cosφ unit with power factor correction	(2)		0,96	0,96	0,96	0,95	0,95	0,95	0,95	0,96	0,95
Max. inrush current (MIC)	(3)	A	122	137	145	148	176	216	267	273	321
Maximum inrush current with soft-starter (MIC)	(4)	A	82	93	98	101	120	146	177	183	212
Power supply		V/ph/Hz	400/3~+N/50								
Power supply for auxiliary circuits		V/ph/Hz	230-24/1~/52								
Suggested line section	(5)	mm ²	5G10 mm2 FG16OR16	5G16 mm2 FG16OR16	5G16 mm2 FG16OR16	5G16 mm2 FG16OR16	5G16 mm2 FG16OR16	5G25 mm2 FG16OR16	5G25 mm2 FG16OR16	5G35 mm2 FG16OR16	4G50 mm2 FG16OR16
Suggested line protection	(6)		NH00gG 50A	NH00gG 63A	NH00gG 63A	NH00gG 80A	NH00gG 80A	NH00gG 100A	NH00gG 100A	NH00gG 125A	NH00gG 160A
Electrical specifications for fans											
Rated power of fan standard		n° x kW	2 x 0,6	2 x 0,6	2 x 0,6	2 x 0,6	2 x 0,6	3 x 0,6	3 x 0,6	3 x 0,6	2 x 2,0
Rated current of fan standard		n° x A	2 x 2,6	2 x 2,6	2 x 2,6	2 x 2,6	2 x 2,6	3 x 2,6	3 x 2,6	3 x 2,6	2 x 4,3
Rated power of fan EC		n° x kW	2 x 0,8	2 x 0,8	2 x 0,8	2 x 0,8	2 x 0,8	3 x 0,8	3 x 0,8	3 x 0,8	2 x 1,9
Rated current of fan EC		n° x A	2 x 1,4	2 x 1,4	2 x 1,4	2 x 1,4	2 x 1,4	3 x 1,4	3 x 1,4	3 x 1,4	2 x 2,9
Rated power of fan oversize EC		n° x kW	2 x 1,0	2 x 1,0	2 x 1,0	2 x 1,0	2 x 1,0	3 x 1,0	3 x 1,0	3 x 1,0	2 x 3,0
Rated current of fan oversize EC		n° x A	2 x 1,6	2 x 1,6	2 x 1,6	2 x 1,6	2 x 1,6	3 x 1,6	3 x 1,6	3 x 1,6	2 x 4,5
			13.2	15.2	16.2	14.4	16.4	18.4	20.4	24.4	
General electrical specifications											
Max. absorbed power (FLI)	(1)	kW	59,2	67,7	76,2	62,6	71,8	85,1	96,4	108,4	
Max. absorbed current (FLA)	(1)	A	105,6	122,5	139,4	132,6	144,6	160,9	172,9	194,2	
Rated current (Inom)	(2)	A	83	94	104	93	111	124	134	152	
cosφ standard unit	(2)		0,85	0,85	0,85	0,76	0,85	0,85	0,85	0,85	
Nominal current with power factor correction (Inom)	(2)	A	74	84	95	75	89	104	115	132	
cosφ unit with power factor correction	(2)		0,95	0,95	0,95	0,97	0,95	0,96	0,96	0,96	
Max. inrush current (MIC)	(3)	A	329	367	384	242	285	346	358	418	
Maximum inrush current with soft-starter (MIC)	(4)	A	220	243	260	186	215	256	268	309	
Power supply		V/ph/Hz	400/3~+N/50								
Power supply for auxiliary circuits		V/ph/Hz	230-24/1~/52								
Suggested line section	(5)	mm ²	4G50 mm2 FG16OR16	4G50 mm2 FG16OR16	4G70 mm2 FG16OR16	4G50 mm2 FG16OR16	4G70 mm2 FG16OR16	4G70 mm2 FG16OR16	4G95 mm2 FG16OR16	4G95 mm2 FG16OR16	
Suggested line protection	(6)		NH00gG 160A	NH00gG 160A	NH1gG 200A	NH00gG 160A	NH1gG 200A	NH1gG 200A	NH1gG 250A	NH1gG 250A	
Electrical specifications for fans											
Rated power of fan standard		n° x kW	2 x 2,0	2 x 2,0	2 x 2,0	2 x 2,0	2 x 2,0	3 x 2,0	3 x 2,0	4 x 2,0	
Rated current of fan standard		n° x A	2 x 4,3	2 x 4,3	2 x 4,3	2 x 4,3	2 x 4,3	3 x 4,3	3 x 4,3	4 x 4,3	
Rated power of fan EC		n° x kW	2 x 1,9	2 x 1,9	2 x 1,9	2 x 1,9	2 x 1,9	3 x 1,9	3 x 1,9	4 x 1,9	
Rated current of fan EC		n° x A	2 x 2,9	2 x 2,9	2 x 2,9	2 x 2,9	2 x 2,9	3 x 2,9	3 x 2,9	4 x 2,9	
Rated power of fan oversize EC		n° x kW	2 x 3,0	2 x 3,0	2 x 3,0	2 x 3,0	2 x 3,0	3 x 3,0	3 x 3,0	4 x 3,0	
Rated current of fan oversize EC		n° x A	2 x 4,5	2 x 4,5	2 x 4,5	2 x 4,5	2 x 4,5	3 x 4,5	3 x 4,5	4 x 4,5	

(1) Data regarding the unit without accessories working in maximum power absorption conditions

(2) Datum related to the unit without accessories working in standard conditions (A35°C; W12/7°C)

(3) Maximum effective RMS value of the current when the last compressor starts (FLA of the entire unit - FLA of the largest compressor + LRA of the largest compressor)

(4) Maximum effective RMS value of the current when the last compressor starts (FLA of the entire unit - FLA of the largest compressor + 0.6 x LRA of the largest compressor)

(5) These values are determined for cables with operating temperature of 40°C, EPR insulation and a line with a maximum length of 50m. The line section must be determined by a qualified technician based on the protection devices, the length of the line, the type of cable used and the type of installation.

(6) The correct line protection part must be determined by a qualified technician based on the length of the line, the type of cable used and the type of installation.

ZETA REV HE - ZETA REV SLN

			3.2	4.2	5.2	6.2	7.2	8.2	9.2	
General electrical specifications										
Max. absorbed power (FLI)	(1)	kW	18,3	21,4	24,5	27,8	31,1	37,9	43,6	
Max. absorbed current (FLA)	(1)	A	37,6	47,2	49,2	57,9	69,9	76,6	82,6	
Rated current (Inom)	(2)	A	32	36	41	46,6	51,6	62,8	66,8	
cosφ standard unit	(2)		0,8	0,8	0,8	0,82	0,81	0,78	0,81	
Nominal current with power factor correction (Inom)	(2)	A	28	30	34	39,6	44,6	52,8	56,8	
cosφ unit with power factor correction	(2)		0,96	0,96	0,96	0,95	0,95	0,95	0,95	
Max. inrush current (MIC)	(3)	A	122	137	145	151	179	217	268	
Maximum inrush current with soft-starter (MIC)	(4)	A	82	93	98	104	123	147	178	
Power supply		V/ph/Hz	400/3~+N/50					400/3~/52		
Power supply for auxiliary circuits		V/ph/Hz	230-24/1~/52							
Suggested line section	(5)	mm²	5G10 mm2 FG16OR16	5G16 mm2 FG16OR16	5G16 mm2 FG16OR16	5G16 mm2 FG16OR16	5G16 mm2 FG16OR16	5G25 mm2 FG16OR16	4G25 mm2 FG16OR16	
Suggested line protection	(6)		NH00gG 50A	NH00gG 63A	NH00gG 63A	NH00gG 80A	NH00gG 80A	NH00gG 100A	NH00gG 100A	
Electrical specifications for fans										
Rated power of fan standard		n° x kW	2 x 0,6	2 x 0,6	2 x 0,6	3 x 0,6	3 x 0,6	2 x 2,0	2 x 2,0	
Rated current of fan standard		n° x A	2 x 2,6	2 x 2,6	2 x 2,6	3 x 2,6	3 x 2,6	2 x 4,3	2 x 4,3	
Rated power of fan EC		n° x kW	2 x 0,8	2 x 0,8	2 x 0,8	3 x 0,8	3 x 0,8	2 x 1,9	2 x 1,9	
Rated current of fan EC		n° x A	2 x 1,4	2 x 1,4	2 x 1,4	3 x 1,4	3 x 1,4	2 x 2,9	2 x 2,9	
Rated power of fan oversize EC		n° x kW	2 x 1,0	2 x 1,0	2 x 1,0	3 x 1,0	3 x 1,0	2 x 3,0	2 x 3,0	
Rated current of fan oversize EC		n° x A	2 x 1,6	2 x 1,6	2 x 1,6	3 x 1,6	3 x 1,6	2 x 4,5	2 x 4,5	

			10.2	12.2	13.2	15.2	16.2	14.4	16.4
General electrical specifications									
Max. absorbed power (FLI)	(1)	kW	49,2	54,2	61,2	69,7	78,2	64,6	73,8
Max. absorbed current (FLA)	(1)	A	88,6	97,1	109,9	126,8	143,7	136,9	148,9
Rated current (Inom)	(2)	A	71,8	76	87,3	98,3	108,3	97,3	115,3
cosφ standard unit	(2)		0,83	0,84	0,85	0,85	0,85	0,76	0,85
Nominal current with power factor correction (Inom)	(2)	A	61,8	67	78,3	88,3	99,3	79,3	93,3
cosφ unit with power factor correction	(2)		0,96	0,95	0,95	0,95	0,95	0,97	0,95
Max. inrush current (MIC)	(3)	A	274	321	333	371	388	246	289
Maximum inrush current with soft-starter (MIC)	(4)	A	184	212	225	247	264	190	219
Power supply		V/ph/Hz	400/3~/52						
Power supply for auxiliary circuits		V/ph/Hz	230-24/1~/52						
Suggested line section	(5)	mm²	4G35 mm2 FG16OR16	4G50 mm2 FG16OR16	4G50 mm2 FG16OR16	4G50 mm2 FG16OR16	4G70 mm2 FG16OR16	4G50 mm2 FG16OR16	4G70 mm2 FG16OR16
Suggested line protection	(6)		NH00gG 125A	NH00gG 160A	NH00gG 160A	NH00gG 160A	NH1gG 200A	NH00gG 160A	NH1gG 200A
Electrical specifications for fans									
Rated power of fan standard		n° x kW	2 x 2,0	2 x 2,0	3 x 2,0	3 x 2,0	3 x 2,0	3 x 2,0	3 x 2,0
Rated current of fan standard		n° x A	2 x 4,3	2 x 4,3	3 x 4,3	3 x 4,3	3 x 4,3	3 x 4,3	3 x 4,3
Rated power of fan EC		n° x kW	2 x 1,9	2 x 1,9	3 x 1,9	3 x 1,9	3 x 1,9	3 x 1,9	3 x 1,9
Rated current of fan EC		n° x A	2 x 2,9	2 x 2,9	3 x 2,9	3 x 2,9	3 x 2,9	3 x 2,9	3 x 2,9
Rated power of fan oversize EC		n° x kW	2 x 3,0	2 x 3,0	3 x 3,0	3 x 3,0	3 x 3,0	3 x 3,0	3 x 3,0
Rated current of fan oversize EC		n° x A	2 x 4,5	2 x 4,5	3 x 4,5	3 x 4,5	3 x 4,5	3 x 4,5	3 x 4,5

- (1) Data regarding the unit without accessories working in maximum power absorption conditions
- (2) Datum related to the unit without accessories working in standard conditions (A35°C; W12/7°C)
- (3) Maximum effective RMS value of the current when the last compressor starts (FLA of the entire unit - FLA of the largest compressor + LRA of the largest compressor)
- (4) Maximum effective RMS value of the current when the last compressor starts (FLA of the entire unit - FLA of the largest compressor + 0.6 x LRA of the largest compressor)
- (5) These values are determined for cables with operating temperature of 40°C, EPR insulation and a line with a maximum length of 50m. The line section must be determined by a qualified technician based on the protection devices, the length of the line, the type of cable used and the type of installation.
- (6) The correct line protection part must be determined by a qualified technician based on the length of the line, the type of cable used and the type of installation.

HYDRAULIC MODULES

ZETA REV

			3.2	4.2	5.2	6.2	7.2	8.2	9.2	10.2	12.2
Volume of the expansion vessel		l	5	5	5	18	18	18	18	18	18
Volume of the buffer tank		l	165	165	165	200	200	450	450	450	450
Standard pumps											
Pump model 1P, 2P			P2	P2	P3	P4	P4	P5	P7	P7	P9
Available head 1P	(1)	kPa	145	135	162	133	148	168	177	165	172
Available head 2P	(1)	kPa	137	125	149	117	128	136	162	147	149
Oversize pumps											
Pump model 1PM, 2PM			P6	P6	P6	P6	P6	P8	P8	P8	P11
Available head 1PM	(1)	kPa	255	237	233	218	232	322	320	298	295
Available head 2PM	(1)	kPa	247	227	221	202	212	291	305	280	271
Pumps for glycol											
Pump model 1PG, 2PG			P15	P15	P16	P16	P16	P17	P17	P18	P18
Available head 1PG	(1)	kPa	120	124	168	150	174	153	153	158	146
Available head 2PG	(1)	kPa	105	105	143	138	158	146	143	146	132

			13.2	14.4	15.2	16.2	16.4	18.4	20.4	24.4	
Volume of the expansion vessel		l	18	18	18	18	18	18	18	18	
Volume of the buffer tank		l	450	390	390	390	390	700	700	700	
Standard pumps											
Pump model 1P, 2P			P9	P9	P10	P9	P10	P10	P10	P13	
Available head 1P	(1)	kPa	160	157	184	170	194	176	153	218	
Available head 2P	(1)	kPa	133	120	140	138	153	156	129	188	
Oversize pumps											
Pump model 1PM, 2PM			P11	P11	P11	P11	P12	P12	P12	P14	
Available head 1PM	(1)	kPa	283	279	334	292	344	324	300	281	
Available head 2PM	(1)	kPa	256	242	290	260	303	304	276	250	
Pumps for glycol											
Pump model 1PG, 2PG			P19	P19	P19	P18	P19	P19	P20	P20	
Available head 1PG	(1)	kPa	175	169	148	142	159	126	192	171	
Available head 2PG	(1)	kPa	157	157	133	131	145	118	182	159	

(1) External air temperature 35°C, user-side heat exchanger water inlet/outlet temperature 12/7°C. Values in accordance with EN 14511.

ZETA REV HE

			3.2	4.2	5.2	6.2	7.2	8.2	9.2
Volume of the expansion vessel		l	5	5	18	18	18	18	18
Volume of the buffer tank CH		l	200	200	200	200	200	450	450
Volume of the buffer tank HP		l	165	165	200	200	200	450	450
Standard pumps									
Pump model 1P, 2P			P2	P2	P4	P4	P4	P5	P7
Available head 1P	(1)	kPa	145	128	146	141	136	159	159
Available head 2P	(1)	kPa	136	116	131	120	126	145	142
Oversize pumps									
Pump model 1PM, 2PM			P6	P6	P6	P6	P6	P8	P8
Available head 1PM	(1)	kPa	247	244	234	226	220	311	295
Available head 2PM	(1)	kPa	238	232	219	204	210	297	278
Pumps for glycol									
Pump model 1PG, 2PG			P15	P15	P16	P16	P16	P17	P17
Available head 1PG	(1)	kPa	142	141	176	171	153	130	126
Available head 2PG	(1)	kPa	135	132	164	166	146	121	115

			10.2	12.2	13.2	14.4	15.2	16.2	16.4
Volume of the expansion vessel		l	18	18	18	18	18	18	18
Volume of the buffer tank CH		l	450	450	700	700	700	700	700
Volume of the buffer tank HP		l	450	450	700	700	700	700	700
Standard pumps									
Pump model 1P, 2P			P7	P9	P9	P9	P10	P9	P10
Available head 1P	(1)	kPa	143	159	160	141	174	156	175
Available head 2P	(1)	kPa	121	132	148	126	156	143	158
Oversize pumps									
Pump model 1PM, 2PM			P8	P11	P11	P11	P12	P11	P12
Available head 1PM	(1)	kPa	264	281	282	263	323	278	324
Available head 2PM	(1)	kPa	242	254	270	248	305	265	307
Pumps for glycol									
Pump model 1PG, 2PG			P18	P18	P19	P19	P19	P18	P19
Available head 1PG	(1)	kPa	124	121	165	138	126	112	121
Available head 2PG	(1)	kPa	116	112	160	132	118	107	114

CH: chiller unit; HP: heat pump unit

(1) External air temperature 35°C, user-side heat exchanger water inlet/outlet temperature 12/7°C. Values in accordance with EN 14511.

ZETA REV SLN

			3.2	4.2	5.2	6.2	7.2	8.2	9.2
Volume of the expansion vessel		l	5	5	18	18	18	18	18
Volume of the buffer tank CH		l	200	200	200	200	200	450	450
Volume of the buffer tank HP		l	165	165	200	200	200	450	450
Standard pumps									
Pump model 1P, 2P			P2	P2	P4	P4	P4	P5	P7
Available head 1P	(1)	kPa	145	128	146	141	136	159	159
Available head 2P	(1)	kPa	136	116	131	120	126	145	142
Oversize pumps									
Pump model 1PM, 2PM			P6	P6	P6	P6	P6	P8	P8
Available head 1PM	(1)	kPa	247	244	234	226	220	311	295
Available head 2PM	(1)	kPa	238	232	219	204	210	297	278
Pumps for glycol									
Pump model 1PG, 2PG			P15	P15	P16	P16	P16	P17	P17
Available head 1PG	(1)	kPa	142	141	176	171	153	130	126
Available head 2PG	(1)	kPa	135	132	164	166	146	121	115

			10.2	12.2	13.2	14.4	15.2	16.2	16.4
Volume of the expansion vessel		l	18	18	18	18	18	18	18
Volume of the buffer tank CH		l	450	450	700	700	700	700	700
Volume of the buffer tank HP		l	450	450	700	700	700	700	700
Standard pumps									
Pump model 1P, 2P			P7	P9	P9	P9	P10	P9	P10
Available head 1P	(1)	kPa	143	159	160	141	174	156	175
Available head 2P	(1)	kPa	121	132	148	126	156	143	158
Oversize pumps									
Pump model 1PM, 2PM			P8	P11	P11	P11	P12	P11	P12
Available head 1PM	(1)	kPa	264	281	282	263	323	278	324
Available head 2PM	(1)	kPa	242	254	270	248	305	265	307
Pumps for glycol									
Pump model 1PG, 2PG			P18	P18	P19	P19	P19	P18	P19
Available head 1PG	(1)	kPa	124	121	165	138	126	112	121
Available head 2PG	(1)	kPa	116	112	160	132	118	107	114

CH: chiller unit; HP: heat pump unit

(1) External air temperature 35°C, user-side heat exchanger water inlet/outlet temperature 12/7°C. Values in accordance with EN 14511.

HYDRAULIC MODULES

	Rated power	Rated current	Min. flow rate	Max. flow rate
	kW	A	m ³ /h	m ³ /h
P1	1,1	2,7	3,0	9,0
P2	0,9	2,1	3,6	9,6
P3	0,9	2,4	3,6	9,6
P4	1,1	2,5	7,0	18,0
P5	1,5	3,2	7,0	18,0
P6	1,9	4,2	7,0	18,0
P7	1,9	4,5	12,0	31,2
P8	3,0	6,1	6,0	20,0
P9	2,2	4,5	12,0	42,0
P10	3,0	6,1	12,0	42,0
P11	4,0	8,7	12,0	42,0
P12	5,5	10,4	12,0	42,0
P13	5,5	10,4	24,0	72,0
P14	7,5	13,7	24,0	72,0
P15	1,5	3,2	7,0	18,0
P16	1,9	4,2	7,0	18,0
P17	2,2	4,6	12,0	31,2
P18	3,0	6,1	12,0	42,0
P19	4,0	8,7	12,0	42,0
P20	7,5	13,7	24,0	72,0

USER-SIDE EXCHANGER FLOW RATE FIELDS

The units are sized and optimized for the following nominal conditions: external air 35°C, inlet/outlet of the user-side heat exchanger 12/7°C.

The units can work at design conditions different from nominal conditions, provided that:

- the design condition falls within the operating limits specified below
- the unit is equipped with all the accessories necessary for operation (e.g. brine kit, fan speed adjuster)
- the flow rate at design conditions (that is, of the specific application) must always come within the allowed flow rate ranges specified below. If the design conditions require a water flow rate that does not come within the allowed operating range, you must contact our sales department that will identify the most suitable solution for the specific application.

ZETA REV

	Qmin	Qmax
	m ³ /h	m ³ /h
3.2	3,5	10,5
4.2	3,9	11,7
5.2	4,6	13,7
6.2	5,2	15,5
7.2	5,8	17,3
8.2	7,0	21,0
9.2	8,0	24,0
10.2	8,8	26,4
12.2	10,0	30,1
13.2	10,8	32,4
15.2	12,6	37,9
16.2	13,7	41,2
14.4	11,8	35,4
16.4	13,2	39,7
18.4	16,3	49,0
20.4	17,9	53,8
24.4	20,1	60,4

ZETA REV HE

	Qmin	Qmax
	m ³ /h	m ³ /h
3.2	3,7	11,0
4.2	4,2	12,7
5.2	5,0	15,1
6.2	5,5	16,4
7.2	6,2	18,7
8.2	7,5	22,6
9.2	8,7	26,1
10.2	9,6	28,8
12.2	11,0	33,1
13.2	12,0	36,0
15.2	13,7	41,1
16.2	15,5	46,5
14.4	12,5	37,4
16.4	14,8	44,4

ZETA REV SLN

	Qmin	Qmax
	m ³ /h	m ³ /h
3.2	3,5	10,6
4.2	4,0	11,9
5.2	4,5	13,6
6.2	5,4	16,1
7.2	6,1	18,3
8.2	7,3	21,8
9.2	8,2	24,7
10.2	9,2	27,6
12.2	10,1	30,4
13.2	11,8	35,4
15.2	13,3	39,8
16.2	14,7	44,0
14.4	12,2	36,7
16.4	14,0	42,0

OPERATING LIMITS

ZETA REV

COOLING

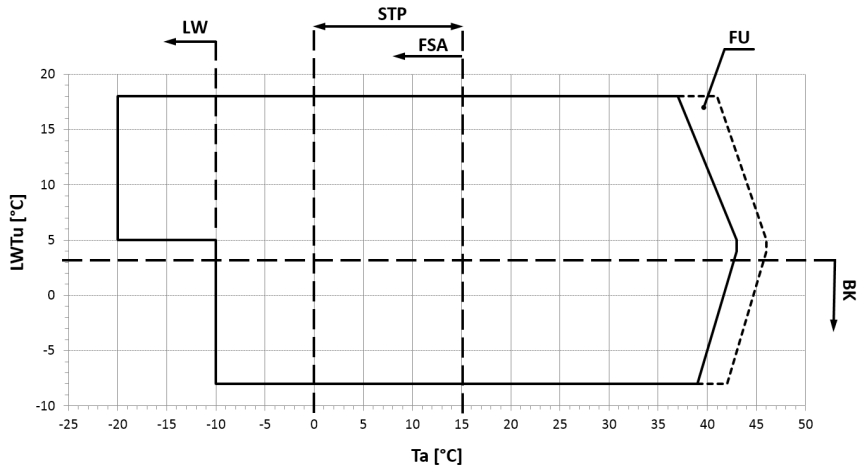

TOTAL RECOVERY

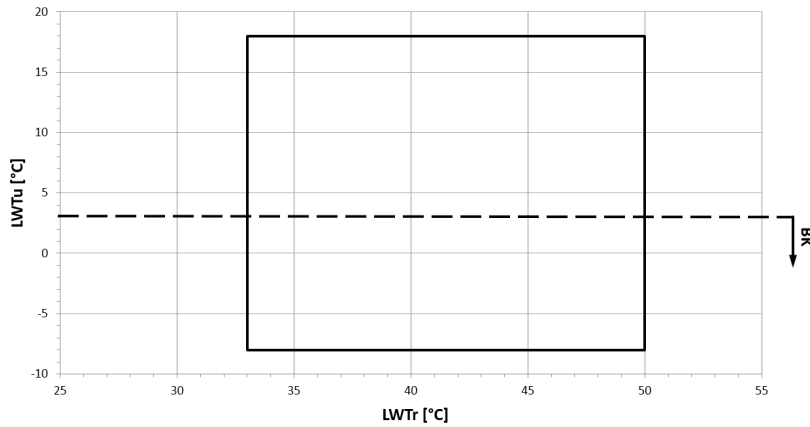

- Ta:** external air temperature
- LWTu:** water outlet temperature from the user-side heat exchanger
- LWTr:** water outlet temperature from the recovery exchanger
- FSA:** to work in the area indicated by the arrow, it is mandatory to include the "Fan speed adjuster" accessory or the "EC fans" accessory
- LW:** in the indicated area, the unit can work only where there is no wind
- FU:** in the indicated area, the control could actuate a forced capacity reduction of the compressors so as to prevent tripping of the safety devices
- STP:** for external air temperatures of between +15°C and 0°C, the unit can work only if equipped with the "Condensing control by steps" accessory. For temperatures below 0°C, the unit can work only if fitted with the accessories indicated in the FSA note.
- BK:** For LWTu lower or equal to +3°C, it is mandatory to fit the "Brine Kit" accessory

For LWTu below +5°C, it is compulsory to use suitable percentages of antifreeze additives (glycols) to prevent ice formation in the exchanger.

The inlet and outlet temperatures of the user-side exchanger must be given on ordering to allow correct setting of the alarm parameters and verification of the sizing of the expansion valve.

The cooling set point can then be changed by the customer in an interval that, compared to the set point given on ordering, ranges from -1K up to the maximum temperature allowed by the above-stated operating limits.

The unit will be optimized to work at the set point temperatures given on ordering. For different set points, the cooling capacity provided and the level of efficiency of the machine could decrease and move away from these conditions.

HEATING

For models Zeta Rev 3.2, 4.2, 5.2, 6.2, 7.2, 8.2, 14.4, 16.4

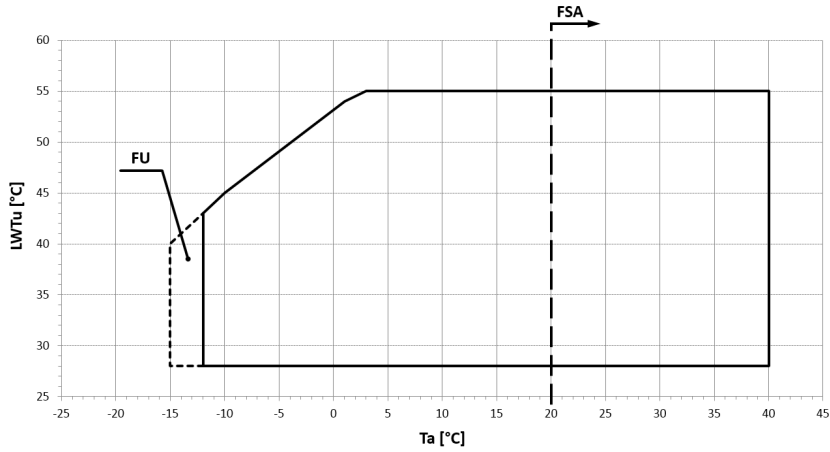

For models Zeta Rev 9.2, 10.2, 16.2, 18.4, 20.4

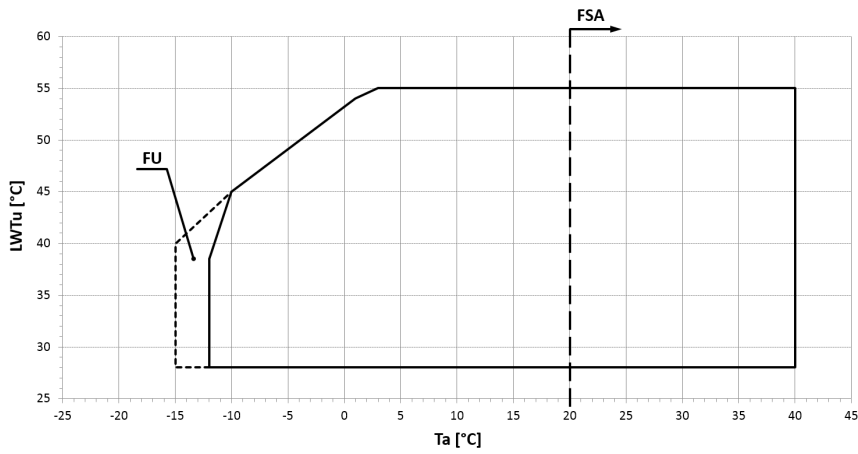

For models Zeta Rev 12.2, 13.2, 15.2, 24.4

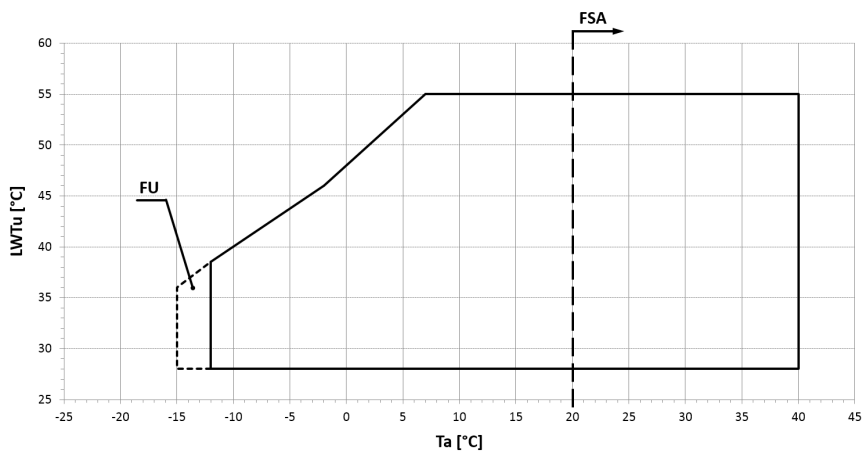

ZETA REV HE - ZETA REV SLN

COOLING

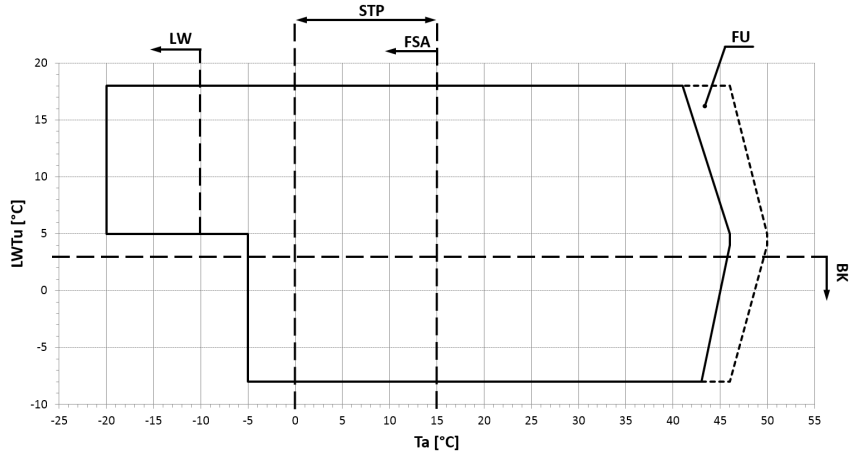

TOTAL RECOVERY

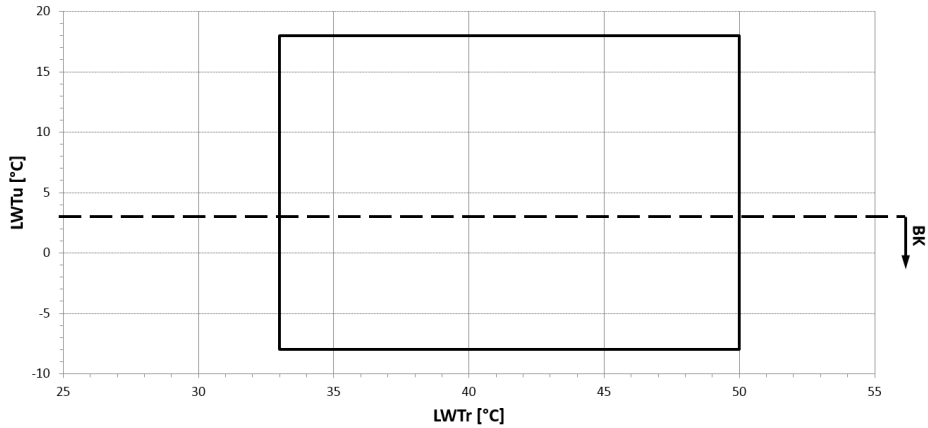

- Ta:** external air temperature
- LWTu:** water outlet temperature from the user-side heat exchanger
- LWTr:** water outlet temperature from the recovery exchanger
- FSA:** to work in the area indicated by the arrow, it is mandatory to include the "Fan speed adjuster" accessory or the "EC fans" accessory
- LW:** in the indicated area, the unit can work only where there is no wind
- FU:** in the indicated area, the control could actuate a forced capacity reduction of the compressors so as to prevent tripping of the safety devices
- STP:** for external air temperatures of between +15°C and 0°C, the unit can work only if equipped with the "Condensing control by steps" accessory. For temperatures below 0°C, the unit can work only if fitted with the accessories indicated in the FSA note.
- BK:** For LWTu lower or equal to +3°C, it is mandatory to fit the "Brine Kit" accessory

For LWTu below +5°C, it is compulsory to use suitable percentages of antifreeze additives (glycols) to prevent ice formation in the exchanger.

The inlet and outlet temperatures of the user-side exchanger must be given on ordering to allow correct setting of the alarm parameters and verification of the sizing of the expansion valve.

The cooling set point can then be changed by the customer in an interval that, compared to the set point given on ordering, ranges from -1K up to the maximum temperature allowed by the above-stated operating limits.

The unit will be optimized to work at the set point temperatures given on ordering. For different set points, the cooling capacity provided and the level of efficiency of the machine could decrease and move away from these conditions.

HEATING

For models Zeta Rev 3.2, 4.2, 5.2, 6.2, 7.2, 8.2, 14.4, 16.4

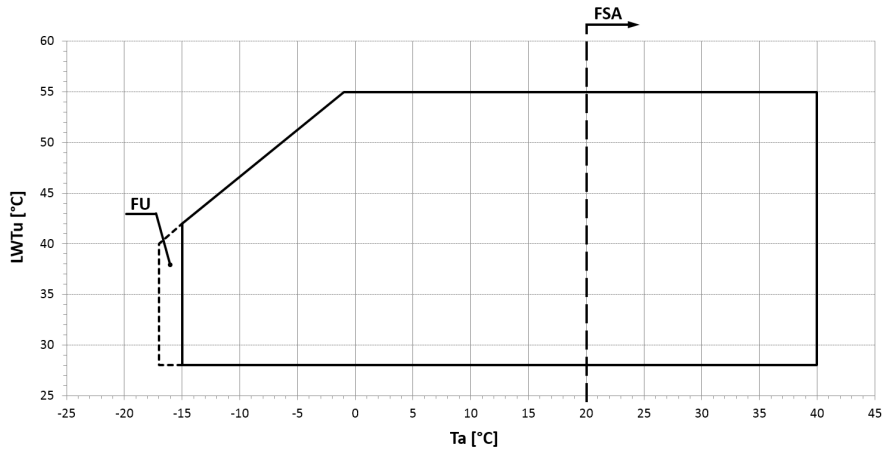

For models Zeta Rev 9.2, 10.2, 16.2, 18.4, 20.4

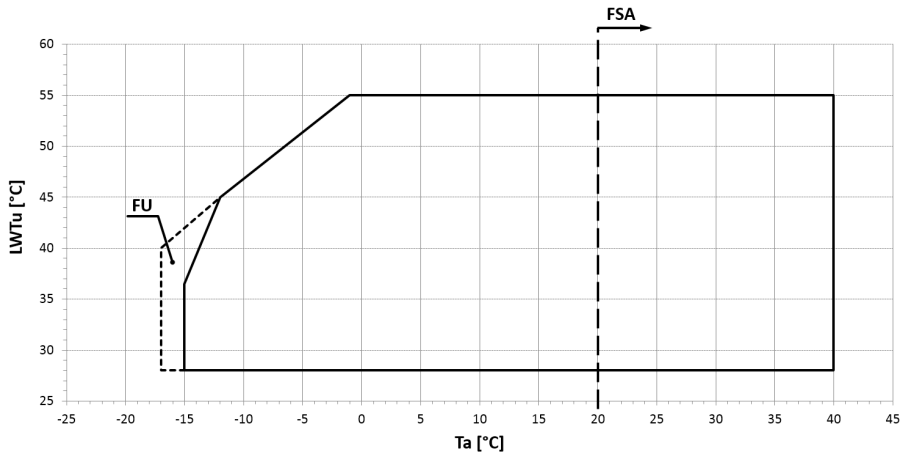

For models Zeta Rev 12.2, 13.2, 15.2, 24.4

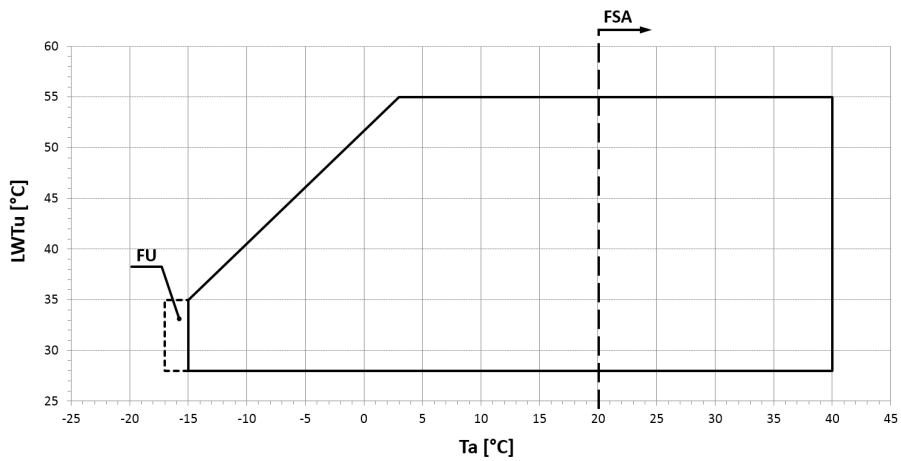

ZETA REV LE

COOLING

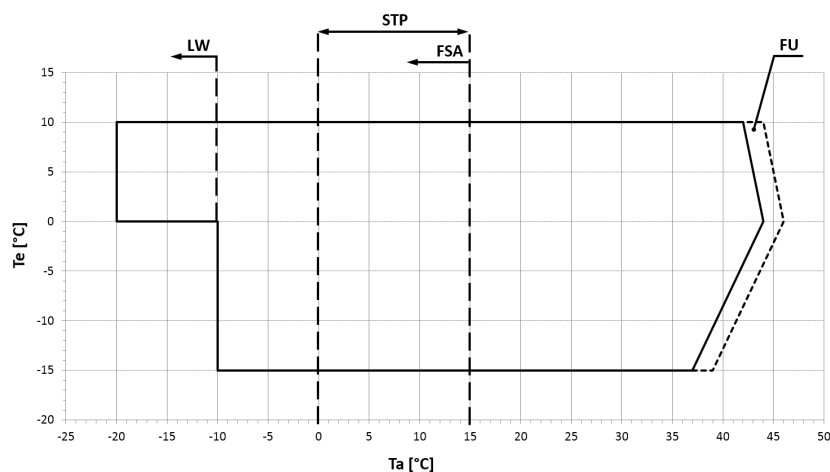

TOTAL RECOVERY

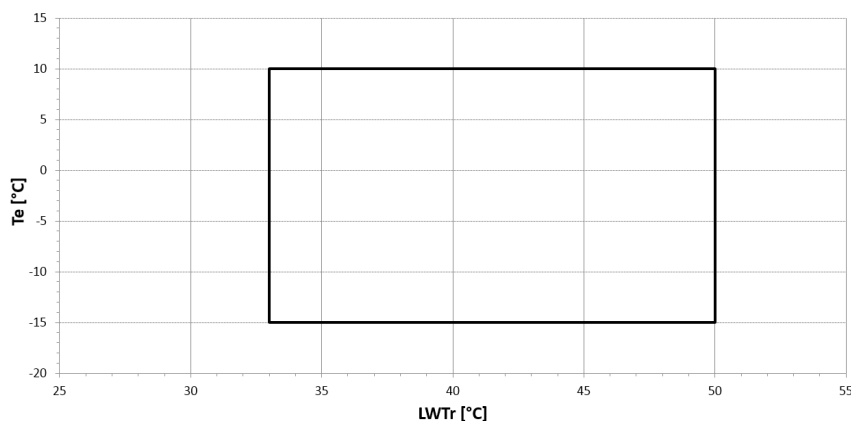

Ta: external air temperature

Te: evaporating temperature

Tc: condensing temperature

LWTr: water outlet temperature from the recovery exchanger

FSA: to work in the area indicated by the arrow, it is mandatory to include the "Fan speed adjuster" accessory or the "EC fans" accessory

LW: in the indicated area, the unit can work only where there is no wind

FU: in the indicated area, the control could actuate a forced capacity reduction of the compressors so as to prevent tripping of the safety devices

STP: for external air temperatures of between +15°C and 0°C, the unit can work only if equipped with the "Condensing control by steps" accessory. For temperatures below 0°C, the unit can work only if fitted with the accessories indicated in the FSA note.

For water outlet temperatures from the user-side heat exchanger below +5°C, it is compulsory to use suitable percentages of anti-freeze additives (glycols) to prevent ice formation in the heat exchanger.

The inlet and outlet temperatures of the user-side exchanger must be given on ordering to allow correct setting of the alarm parameters and verification of the sizing of the expansion valve.

The cooling set point can then be changed by the customer in an interval that, compared to the set point given on ordering, ranges from -1K up to the maximum temperature allowed by the above-stated operating limits.

The unit will be optimized to work at the set point temperatures given on ordering. For different set points, the cooling capacity provided and the level of efficiency of the machine could decrease and move away from these conditions.

HEATING

For models Zeta Rev 3.2, 4.2, 5.2, 6.2, 7.2, 8.2, 14.4, 16.4

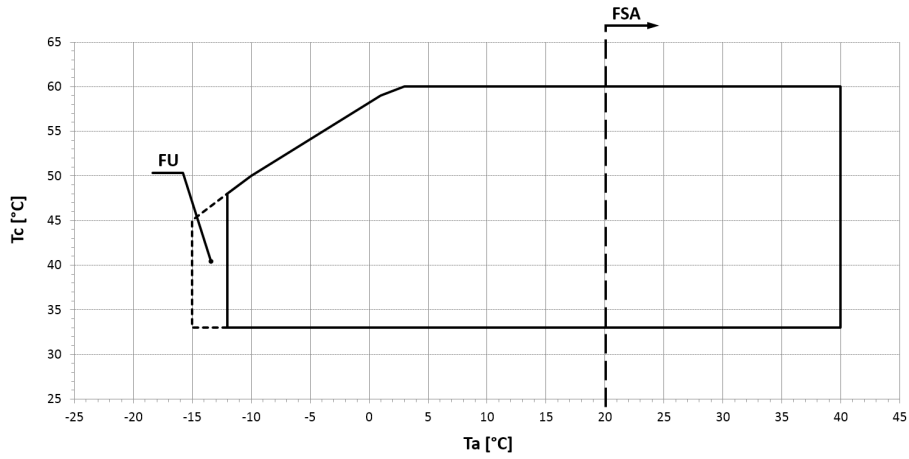

For models Zeta Rev 9.2, 10.2, 16.2, 18.4, 20.4

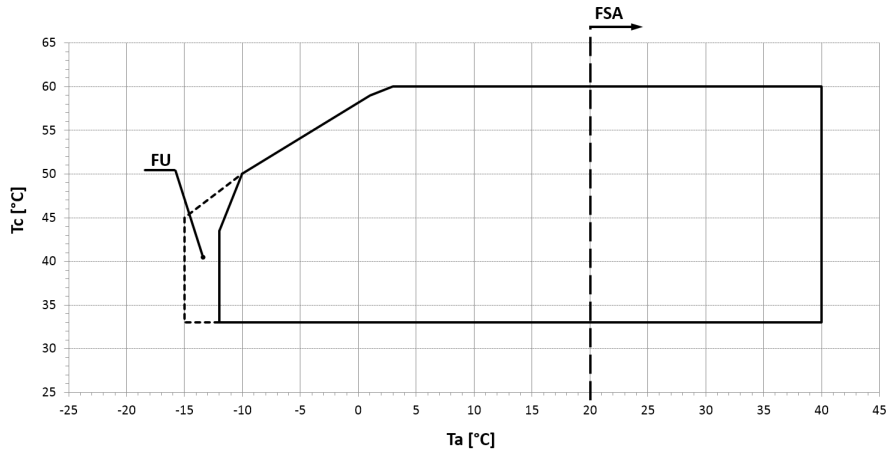

For models Zeta Rev 12.2, 13.2, 15.2, 24.4

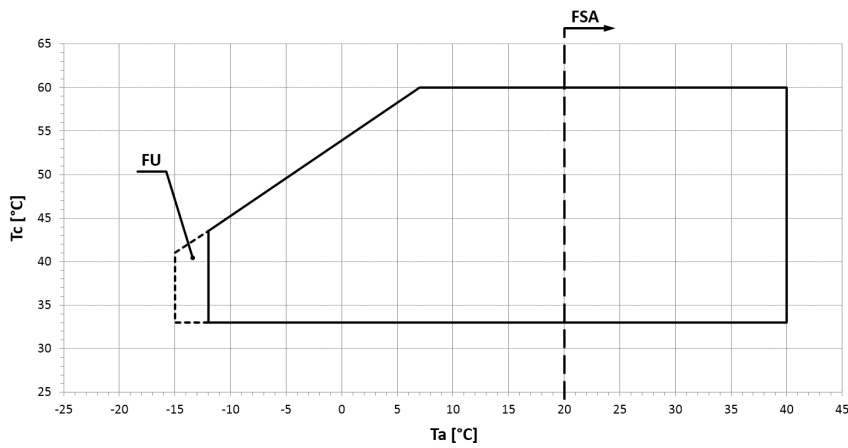

NOISE LEVELS

ZETA REV

	Octave bands [dB]																Total [dB(A)]	
	63 Hz		125 Hz		250 Hz		500 Hz		1000 Hz		2000 Hz		4000 Hz		8000 Hz		Lw_tot	Lp_tot
	Lw	Lp	Lw	Lp	Lw	Lp	Lw	Lp	Lw	Lp	Lw	Lp	Lw	Lp	Lw	Lp		
3.2	79	48	78	47	70	38	73	41	72	41	71	39	69	38	64	32	78	46
4.2	79	48	78	47	70	39	74	42	73	42	74	42	70	39	65	34	79	48
5.2	79	48	78	47	70	38	74	43	74	43	73	41	70	38	65	33	79	48
6.2	79	48	78	47	69	38	72	41	75	43	75	43	71	39	67	36	80	48
7.2	79	48	78	47	70	38	75	43	75	44	75	44	72	40	67	35	81	49
8.2	81	49	80	48	71	39	75	43	76	44	77	45	73	41	68	36	82	50
9.2	79	47	78	46	74	42	75	43	76	44	79	47	72	40	65	33	83	51
10.2	80	48	78	46	76	44	77	45	77	45	81	49	73	41	64	32	84	52
12.2	84	52	74	42	77	45	78	46	80	48	82	50	75	43	69	37	86	54
13.2	84	52	74	42	77	45	78	46	81	49	83	51	76	44	71	39	87	55
15.2	84	52	74	42	77	45	79	47	82	50	82	50	76	44	70	38	87	55
16.2	84	52	74	42	77	45	79	47	82	50	82	50	76	44	69	37	87	55
14.4	87	55	76	44	75	43	79	47	79	47	79	47	75	43	70	38	84	52
16.4	87	55	76	44	75	43	79	47	80	48	80	48	76	44	71	39	85	53
18.4	87	55	77	45	79	47	81	49	80	48	83	51	76	44	70	38	87	55
20.4	88	56	78	46	81	49	82	50	81	49	85	53	77	45	69	37	89	57
24.4	89	57	79	47	81	49	82	50	84	52	86	54	79	47	73	41	90	58

ZETA REV /LN

	Octave bands [dB]																Total [dB(A)]	
	63 Hz		125 Hz		250 Hz		500 Hz		1000 Hz		2000 Hz		4000 Hz		8000 Hz		Lw_tot	Lp_tot
	Lw	Lp	Lw	Lp	Lw	Lp	Lw	Lp	Lw	Lp	Lw	Lp	Lw	Lp	Lw	Lp		
3.2	77	45	76	45	68	36	71	39	70	39	69	37	67	36	62	31	76	44
4.2	77	45	76	45	68	37	72	40	71	40	71	40	68	37	63	32	77	46
5.2	77	45	76	45	68	36	72	41	72	41	71	39	68	36	63	32	77	46
6.2	77	46	76	45	68	36	70	39	73	41	73	41	69	37	66	34	78	46
7.2	77	46	76	45	68	36	73	41	73	42	73	42	70	38	65	34	79	47
8.2	79	47	78	46	70	38	73	41	74	42	75	43	71	39	66	34	80	48
9.2	77	45	76	44	72	40	73	41	74	42	77	45	70	38	64	32	81	49
10.2	78	46	76	44	75	43	75	43	75	43	79	47	71	39	62	30	82	50
12.2	82	50	72	40	75	43	76	44	78	46	80	48	73	41	67	35	84	52
13.2	82	50	72	40	75	43	76	44	79	47	81	49	75	43	69	37	85	53
15.2	82	50	72	40	75	43	77	45	80	48	80	48	74	42	68	36	85	53
16.2	82	50	72	40	75	43	77	45	80	48	80	48	74	42	67	35	85	53
14.4	84	52	74	42	73	41	77	45	77	45	77	45	73	41	68	36	82	50
16.4	84	52	74	42	73	41	77	45	78	46	78	46	74	42	69	37	83	51
18.4	85	53	76	44	77	45	79	47	79	47	81	49	74	42	68	36	85	53
20.4	86	54	76	44	79	47	80	48	79	47	83	51	75	43	67	35	87	55
24.4	87	55	77	45	80	48	80	48	82	50	84	52	78	46	71	39	88	56

The acoustic data are related to standard conditions (source on a reflective surface in free field) in referable and reproducible operating conditions. The environment and the installation conditions, as well as the operating modes, can alter the sound emissions.

Reference conditions: external air temperature 35°C; evaporator inlet/outlet water temperature 12/7°C; unit without accessories operating at nominal regime.

Lw: sound power levels. Lw Total is the only binding value. Tolerance in accordance with regulation 2016/2281.

Lp: sound pressure levels calculated from sound power levels, related to distance of 10 metres; source installed on a reflective surface in ideal free field conditions with directivity factor Q=2. Non-binding value; data (including Lp Total) are provided for illustrative purposes only and can not be used for forecasting purposes or for verification of mandatory limits.

ZETA REV HE

Octave bands [dB]																	Total	
	63 Hz		125 Hz		250 Hz		500 Hz		1000 Hz		2000 Hz		4000 Hz		8000 Hz		[dB(A)]	
	Lw	Lp	Lw	Lp	Lw	Lp	Lw	Lp	Lw	Lp	Lw	Lp	Lw	Lp	Lw	Lp	Lw	Lp
3.2	79	48	78	47	70	38	73	41	72	41	71	39	69	38	64	32	78	46
4.2	79	48	78	47	70	39	74	42	73	42	74	42	70	39	65	34	79	48
5.2	79	48	78	47	70	38	74	43	74	43	73	41	70	38	65	33	79	48
6.2	81	49	80	48	71	39	73	41	75	43	75	43	71	39	68	36	80	48
7.2	81	49	80	48	71	39	75	43	76	44	76	44	72	40	67	35	81	49
8.2	85	53	75	43	73	41	76	44	77	45	77	45	73	41	68	36	82	50
9.2	85	53	75	43	76	44	77	45	77	45	79	47	73	41	66	34	83	51
10.2	84	52	75	43	77	45	78	46	77	45	81	49	73	41	65	33	84	52
12.2	84	52	74	42	77	45	78	46	80	48	82	50	75	43	69	37	86	54
13.2	86	54	76	44	78	46	79	47	81	49	83	51	77	45	71	39	87	55
15.2	86	54	76	44	78	46	79	47	82	50	83	51	76	44	70	38	87	55
16.2	86	54	76	44	78	46	80	48	83	51	82	50	76	44	70	38	87	55
14.4	88	56	78	46	76	44	79	47	79	47	79	47	75	43	70	38	84	52
16.4	88	56	78	46	76	44	79	47	80	48	80	48	76	44	71	39	85	53

ZETA REV HE /LN

Octave bands [dB]																	Total	
	63 Hz		125 Hz		250 Hz		500 Hz		1000 Hz		2000 Hz		4000 Hz		8000 Hz		[dB(A)]	
	Lw	Lp	Lw	Lp	Lw	Lp	Lw	Lp	Lw	Lp	Lw	Lp	Lw	Lp	Lw	Lp	Lw	Lp
3.2	77	45	76	45	68	36	71	39	70	39	69	37	67	36	62	31	76	44
4.2	77	45	76	45	68	37	72	40	71	40	71	40	68	37	63	32	77	46
5.2	77	45	76	45	68	36	72	41	72	41	71	39	68	36	63	32	77	46
6.2	79	47	78	46	69	37	71	39	73	41	73	41	69	37	66	34	78	46
7.2	79	47	78	46	69	37	73	41	74	42	74	42	70	38	66	34	79	47
8.2	83	51	73	41	72	40	74	42	75	43	75	43	71	39	66	34	80	48
9.2	82	50	73	41	74	42	75	43	75	43	77	45	71	39	65	33	81	49
10.2	82	50	73	41	75	43	76	44	75	43	79	47	71	39	63	31	82	50
12.2	82	50	72	40	75	43	76	44	78	46	80	48	73	41	67	35	84	52
13.2	84	52	74	42	76	44	77	45	79	47	81	49	75	43	69	37	85	53
15.2	84	52	74	42	76	44	77	45	80	48	81	49	75	43	69	37	85	53
16.2	84	52	74	42	76	44	78	46	81	49	80	48	74	42	68	36	85	53
14.4	86	54	76	44	74	42	77	45	77	45	77	45	73	41	69	37	82	50
16.4	86	54	76	44	74	42	77	45	78	46	78	46	74	42	69	37	83	51

The acoustic data are related to standard conditions (source on a reflective surface in free field) in referable and reproducible operating conditions. The environment and the installation conditions, as well as the operating modes, can alter the sound emissions.

Reference conditions: external air temperature 35°C; evaporator inlet/outlet water temperature 12/7°C; unit without accessories operating at nominal regime.

Lw: sound power levels. Lw Total is the only binding value. Tolerance in accordance with regulation 2016/2281.

Lp: sound pressure levels calculated from sound power levels, related to distance of 10 metres; source installed on a reflective surface in ideal free field conditions with directivity factor Q=2. Non-binding value; data (including Lp Total) are provided for illustrative purposes only and can not be used for forecasting purposes or for verification of mandatory limits.

ZETA REV SLN

	Octave bands [dB]																Total	
	63 Hz		125 Hz		250 Hz		500 Hz		1000 Hz		2000 Hz		4000 Hz		8000 Hz		[dB(A)]	
	Lw	Lp	Lw	Lp	Lw	Lp	Lw	Lp	Lw	Lp	Lw	Lp	Lw	Lp	Lw	Lp	Lw	Lp
3.2	72	40	70	38	65	33	69	38	69	37	67	35	66	34	60	28	74	42
4.2	71	40	70	38	65	33	70	39	69	38	70	38	67	35	61	30	75	44
5.2	71	40	70	38	64	33	70	39	70	39	69	37	66	34	61	29	75	44
6.2	73	41	71	39	65	33	69	37	71	39	71	39	67	35	64	32	76	44
7.2	73	41	71	39	66	34	71	39	72	40	72	40	68	36	63	31	77	45
8.2	78	46	69	37	67	35	72	40	73	41	73	41	69	37	64	32	78	46
9.2	77	45	68	36	71	39	72	40	73	41	75	43	69	37	62	30	79	47
10.2	77	45	68	36	73	41	74	42	73	41	77	45	69	37	61	29	80	48
12.2	77	45	67	35	73	41	73	41	76	44	78	46	71	39	65	33	82	50
13.2	78	46	69	37	73	41	74	42	77	45	79	47	73	41	67	35	83	51
15.2	78	46	69	37	73	41	75	43	78	46	79	47	73	41	66	34	83	51
16.2	78	46	69	37	73	41	75	43	79	47	78	46	73	41	66	34	83	51
14.4	81	49	71	39	70	38	75	43	75	43	75	43	72	40	67	35	80	48
16.4	80	48	71	39	70	38	74	42	76	44	76	44	72	40	67	35	81	49

The acoustic data are related to standard conditions (source on a reflective surface in free field) in referable and reproducible operating conditions. The environment and the installation conditions, as well as the operating modes, can alter the sound emissions.

Reference conditions: external air temperature 35°C; evaporator inlet/outlet water temperature 12/7°C; unit without accessories operating at nominal regime.

Lw: sound power levels. Lw Total is the only binding value. Tolerance in accordance with regulation 2016/2281.

Lp: sound pressure levels calculated from sound power levels, related to distance of 10 metres; source installed on a reflective surface in ideal free field conditions with directivity factor Q=2. Non-binding value; data (including Lp Total) are provided for illustrative purposes only and can not be used for forecasting purposes or for verification of mandatory limits.

CONFIGURATIONS THAT ARE NOT POSSIBLE

ZETA REV

	CHILLER ONLY								HEAT PUMP			
	/DC /1P	/DC /2P	/DC /1PS	/DC /2PS	/DS /1P	/DS /2P	/DS /1PS	/DS /2PS	HP /DS /1P	HP /DS /2P	HP /DS /1PS	HP /DS /2PS
3.2				n.a.				n.a.				n.a.
4.2				n.a.				n.a.				n.a.
5.2				n.a.				n.a.				n.a.
6.2			n.a.	n.a.				n.a.	n.a.		n.a.	n.a.
7.2			n.a.	n.a.				n.a.	n.a.		n.a.	n.a.
8.2			n.a.	n.a.				n.a.	n.a.		n.a.	n.a.
9.2			n.a.	n.a.				n.a.	n.a.		n.a.	n.a.
10.2			n.a.	n.a.				n.a.	n.a.		n.a.	n.a.
12.2			n.a.	n.a.				n.a.	n.a.		n.a.	n.a.
13.2			n.a.	n.a.				n.a.	n.a.		n.a.	n.a.
15.2	n.a.	n.a.	n.a.	n.a.								
16.2	n.a.	n.a.	n.a.	n.a.								
14.4	n.a.	n.a.	n.a.	n.a.					n.a.	n.a.	n.a.	n.a.
16.4	n.a.	n.a.	n.a.	n.a.					n.a.	n.a.	n.a.	n.a.
18.4	n.a.	n.a.	n.a.	n.a.				n.a.	n.a.		n.a.	n.a.
20.4	n.a.	n.a.	n.a.	n.a.				n.a.	n.a.		n.a.	n.a.
24.4	n.a.	n.a.	n.a.	n.a.				n.a.	n.a.		n.a.	n.a.

ZETA REV HE - ZETA REV SLN

	CHILLER ONLY								HEAT PUMP			
	/DC /1P	/DC /2P	/DC /1PS	/DC /2PS	/DS /1P	/DS /2P	/DS /1PS	/DS /2PS	HP /DS /1P	HP /DS /2P	HP /DS /1PS	HP /DS /2PS
3.2			n.a.	n.a.				n.a.	n.a.			n.a.
4.2			n.a.	n.a.				n.a.	n.a.			n.a.
5.2			n.a.	n.a.				n.a.	n.a.		n.a.	n.a.
6.2			n.a.	n.a.				n.a.	n.a.		n.a.	n.a.
7.2			n.a.	n.a.				n.a.	n.a.		n.a.	n.a.
8.2			n.a.	n.a.				n.a.	n.a.		n.a.	n.a.
9.2			n.a.	n.a.				n.a.	n.a.		n.a.	n.a.
10.2	n.a.	n.a.	n.a.	n.a.								
12.2	n.a.	n.a.	n.a.	n.a.								
13.2			n.a.	n.a.				n.a.	n.a.		n.a.	n.a.
15.2			n.a.	n.a.				n.a.	n.a.		n.a.	n.a.
16.2			n.a.	n.a.				n.a.	n.a.		n.a.	n.a.
14.4			n.a.	n.a.				n.a.	n.a.		n.a.	n.a.
16.4			n.a.	n.a.				n.a.	n.a.		n.a.	n.a.

n.a.: configuration not available

INSTALLATION ADVICE

The units described in this document are, by nature, strongly affected by the characteristics of the system, the working conditions and the installation site.

Remember that the unit must be installed by a qualified and skilled technician, and in compliance with the national legislation in force in the destination country.

The installation must be done in such a way that it will be possible to carry out all routine and non-routine maintenance operations.

Before starting any work, you must carefully read the "Installation, operation and maintenance manual" of the machine and do the necessary safety checks to prevent any malfunctioning or hazards.

We give some advice below that will allow you to increase the efficiency and reliability of the unit and therefore of the system into which it is inserted.

Water characteristics

To preserve the life of the exchangers, the water is required to comply with some quality parameters and it is therefore necessary to make sure its values fall within the ranges indicated in the following table:

Total hardness	2,0 ÷ 6,0 °f
Langelier index	- 0,4 ÷ 0,4
pH	7,5 ÷ 8,5
Electrical conductivity	10 ÷ 500 µS/cm
Organic elements	-
Hydrogen carbonate (HCO₃⁻)	70 ÷ 300 ppm
Sulphates (SO₄²⁻)	< 50 ppm
Hydrogen carbonate / Sulphates (HCO₃⁻/SO₄²⁻)	> 1
Chlorides (Cl⁻)	< 50 ppm
Nitrates (NO₃⁻)	< 50 ppm
Hydrogen sulphide (H₂S)	< 0,05 ppm
Ammonia (NH₃)	< 0,05 ppm
Sulphites (SO₃⁻), free chlorine (Cl₂)	< 1 ppm
Carbon dioxide (CO₂)	< 5 ppm
Metal cations	< 0,2 ppm
Manganese ions (Mn⁺⁺)	< 0,2 ppm
Iron ions (Fe²⁺, Fe³⁺)	< 0,2 ppm
Iron + Manganese	< 0,4 ppm
Phosphates (PO₄³⁻)	< 2 ppm
Oxygen	< 0,1 ppm

Installation of water filters on all the hydraulic circuits is obligatory.

The supply of the most suitable filters for the unit can be requested as accessory. In this case, the filters are supplied loose and must be installed by the customer following the instructions given in the installation, operation and maintenance manual.

Glycol mixtures

With temperatures below 5°C, it is mandatory to work with water and anti-freeze mixtures, and also change the safety devices (anti-freeze, etc.), which must be carried out by qualified authorised personnel or by the manufacturer.

Liquid outlet temperature or minimum ambient temperature	°C	0	-5	-10	-15	-20	-25	-30	-35	-40
Freezing point	°C	-5	-10	-15	-20	-25	-30	-35	-40	-45
Ethylene glycol	%	6	22	30	36	41	46	50	53	56
Propylene glycol	%	15	25	33	39	44	48	51	54	57

The quantity of antifreeze should be considered as % on weight

Minimum water content in the system

For correct operation of the unit, it is necessary to ensure a buffering on the system such as to comply with the minimum operating time considering the greater between the minimum OFF time and the minimum ON time. In short, these contribute to limiting the number of times the compressors are switched on per hour and to preventing undesired deviations from the set point of the delivered water temperature.

Larger amounts of water are in any case always preferable, because they allow a smaller number of starts and switch-offs of the compressors, less wear of them and an increase in the efficiency of the system as a consequence of a reduction in the number of transients.

It should also be pointed out that, for air-water units working in heat pump mode, the minimum amount of water must consider the need of the unit to carry out defrosting. Having an adequate buffering volume will allow prevention of too high drifts of the delivered water temperature at the end of the defrost cycle.

The following experimental formula allows the minimum water volume of the system to be calculated:

$$V_{min} = \frac{P_{tot} \cdot 1.000}{N} \cdot \frac{300}{\Delta T \cdot \rho \cdot c_p} + P_{tot} \cdot 0,25$$

where

V_{min} is the minimum water content of the system measured in l

P_{tot} is the total cooling capacity of the machine measured in kW

N is the number of capacity reduction steps

ΔT is the differential allowed on the water temperature. Unless otherwise specified, this value is considered to be 2.5K
 ρ is the density of the heat-carrying fluid. Unless otherwise specified, the density of water is considered and therefore 1000kg/m³

c_p is the specific heat of the heat-carrying fluid. Unless otherwise specified, the specific heat of water is considered and therefore 4.186kJ/(kgK)

Considering the use of water and grouping together some terms, the formula can be re-written as follows:

$$V_{min} = \frac{P_{tot}}{N} \cdot 17,2 + P_{tot} \cdot 0,25$$

N is equal to the number of compressors installed in the unit.

Installation site

To determine the best installation site for the unit and its orientation, you should pay attention to the following points:

- compliance with the clearance spaces indicated in the official dimensional drawing of the unit must be guaranteed so as to ensure accessibility for routine and non-routine maintenance operations
- you should consider the origin of the hydraulic pipes and their diameters because these affect the radiuses of curvature and therefore the spaces needed for installing them
- you should consider the position of the cable inlet on the electrical control panel of the unit as regards the origin of the power supply
- if the installation includes several units side by side, you should consider the position and dimensions of the manifolds of the user-side exchangers and of any recovery exchangers
- if the installation includes several units side by side, you should consider that the minimum distance between units is 3 metres
- you should avoid all obstructions that can limit air circulation to the source-side exchanger or that can cause recirculation between air supply and intake
- you should consider the orientation of the unit to limit, as far as possible, exposure of the source-side exchanger to solar radiation
- if the installation area is particularly windy, the orientation and positioning of the unit must be such as to avoid air recirculation on the coils. If necessary, we advise making windbreak barriers in order to prevent malfunctioning.

Once the best position for the unit has been identified, you must check that the support slab has the following characteristics:

- its dimensions must be proportionate to those of the unit: if possible, longer and wider than the unit by at least 30 cm and 15/20cm higher than the surrounding surface
- it must be able to bear at least 4 times the operating weight of the unit
- it must allow level installation of the unit: although the unit is installed on a horizontal base, make slopes in the support surface to convey rain water or defrost water to drains, wells or in any case to places where it cannot generate an accident hazard due to ice formation. All heat pump version units are equipped with discharge manifolds for the condensed water; these can be manifolded to facilitate condensate discharge.

The units are designed and built to reduce to a minimum the level of vibration transmitted to the ground, but it is in any case advisable to use rubber or spring anti-vibration mounts, which are available as accessory and should be requested when ordering.

The anti-vibration mounts must be fixed on before positioning the unit on the ground.

In the event of installation on roofs or intermediate floors, the pipes must be isolated from the walls and ceilings.

It is advisable to avoid installation in cramped places, to prevent reverberations, reflections, resonances and acoustic interactions with elements outside the unit.

It is essential that any work done to soundproof the unit does not affect its correct installation or correct operation and, in particular, does not reduce the air flow rate to the source-side exchanger.

Installations that require the use of treated coils

If the unit has to be installed in an environment with a particularly aggressive atmosphere, coils with special treatments are available as options.

The type of coil treatment should be chosen with regard to the environment in which the unit is to be installed, through observation of other structures and machinery with exposed metal surfaces present in the destination environment.

The cross observation criterion is the most valid method of selection currently available without having to carry out preliminary tests or measurements with instruments. The identified reference environments are:

- coastal/marine
- industrial
- urban with a high housing density
- rural

Please note that in cases where different conditions co-exist, even for short periods, the choice must be suitable for preserving the exchanger in the harsher environmental conditions and not in conditions between the worst and best situation.

Particular attention must be given in cases where an environment that is not particularly aggressive becomes aggressive as a consequence of a concomitant cause, for example, the presence of a flue outlet or an extraction fan.

We strongly suggest choosing one of the treatment options if at least one of the points listed below is verified:

- there are obvious signs of corrosion of the exposed metal surfaces in the installation area
- the prevailing winds come from the sea towards the unit
- the environment is industrial with a significant concentration of pollutants
- the environment is urban with a high population density
- the environment is rural with the presence of organic discharges and effluents

In particular, for installations near the coast, the following instructions apply:

for installations between 1 and 20 km from the coast of reversible units or units with Cu/Al coils, we strongly recommend using the accessory "Coil treated with anti-corrosion paints"

for distances within a kilometre of the coast, we strongly recommend using the accessory "Coil treated with anti-corrosion paints" for all units.

To protect the exchangers from corrosion and ensure optimal operation of the unit, we advise following the recommendations given in the user, installation and maintenance manual for cleaning the coils.

Aeraulic head losses and options available for the ventilating section

With the exception of units for which oversized fans are required, as standard, the units are designed considering that, at the nominal air flow rate, the fans work with null available pressure.

If there are obstacles to free air flow, you should consider the additional aeraulic head losses that will cause a reduction of the air flow rate and a consequent deterioration of performance.

The following diagrams show the trend of cooling capacity (P_c), EER, total absorbed power (P_{abs}) and reduction of the maximum external air temperature in chiller operating mode, depending on the aeraulic head losses that the fans will have to overcome.

AC fans (Ø 800)

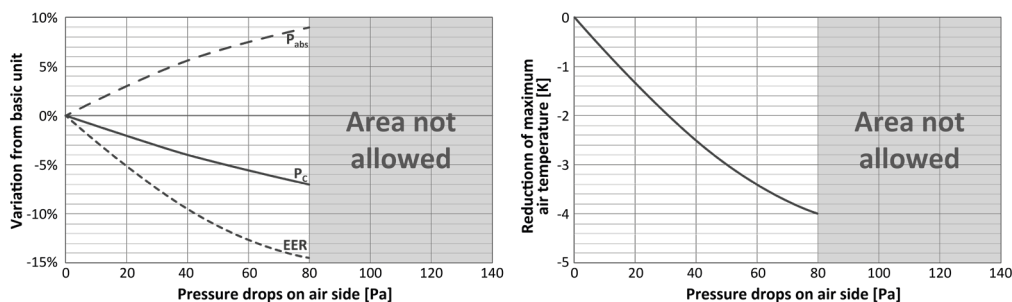

EC fans (Ø 800)

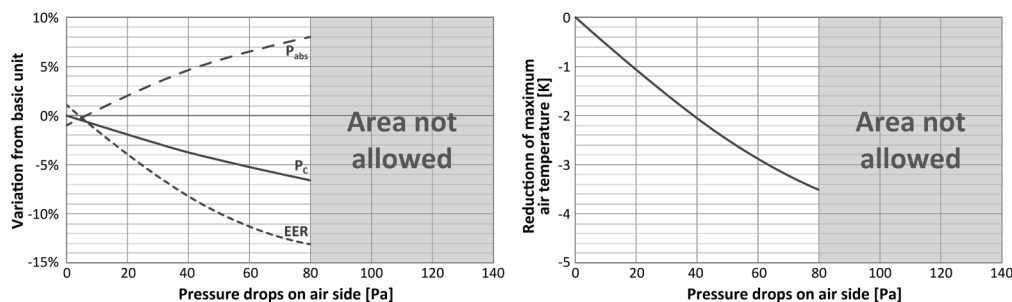

Oversize EC fans (Ø 800)

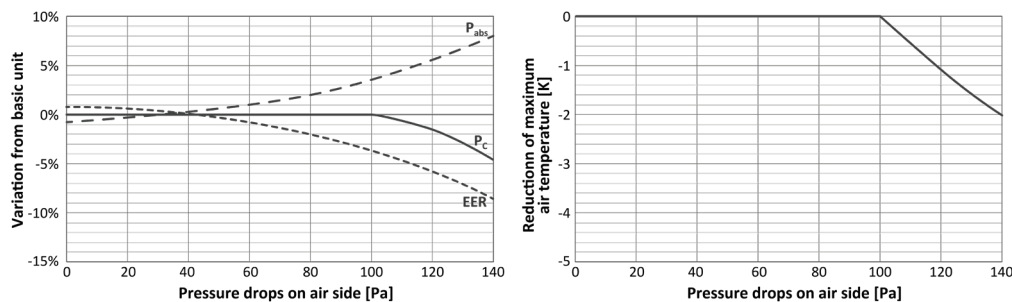

The indicated values are for the standard machine, without accessories, with AC fans and in any case in the absence of air recirculation.

Example: supposing you expect there to be obstacles that will generate an estimated aeraulic head loss of 60Pa. In this case, there are 3 possibilities:

- use the unit with standard AC fans: compared to ideal conditions, the output power will be reduced by about 5.5%, the total absorbed power will increase by about 7.5%, the EER will be reduced by about 12.5% and the maximum allowed external air temperature for operation at 100% will be reduced by about 3.4K compared to the nominal limit
- use the unit with EC fans: compared to the unit with AC fans working in ideal conditions, the output power will be reduced by about 5%, the total absorbed power will increase by about 6.5%, the EER will be reduced by about 11.5% and the maximum allowed external air temperature for operation at 100% will be reduced by about 2.8K compared to the nominal limit
- use the unit with oversize EC fans: compared to the unit with AC fans working in ideal conditions, the output power of the unit will be unchanged, the total absorbed power will increase by about 1%, the EER will be reduced by about 2% and the maximum external air temperature will remain the one shown in the diagram of the operating limits.



Blue Box Group S.r.l.

Via Valletta, 5 - 30010

Cantarana di Cona, (VE) Italy - T. +39 0426 921111 - F. +39 0426 302222

www.blueboxcooling.com - info@bluebox.it



Blue Box Group S.r.l. a socio unico - P.IVA 02481290282

Company directed and coordinated by Investment Latour (Sweden)